

Model | KAH



INSTALLATION GUIDE

Installation, Assembly, Start-up, and Service Instructions

CHANGEABILITY OF THIS DOCUMENT

In complying with Krueger's policy for continuous product improvement, the information contained in this document is subject to change without notice. Krueger makes no commitment to update or provide current information automatically to the manual owner. Updated manuals, if applicable, can be obtained on Krueger's website at www.krueger-hvac.com

Operating/service personnel maintain responsibility for the applicability of these documents to the equipment. If there is any question regarding the applicability of these documents, the technician should verify whether the equipment has been modified and if current literature is available from the owner of the equipment prior to performing any work on the unit.

CHANGE BARS

Revisions made to this document are indicated with a line along the left or right hand column in the area the revision was made. These revisions are to technical information and any other changes in spelling, grammar, or formatting are not included.

TABLE OF CONTENTS

General Safety Guidelines & Safety Symbols	4
Section 1: General Information & Safety	5
Section 2: Product Description	6
<i>Typical AHU Operation, Cleaning, Hand Orientation, and Identification</i>	-- 6
<i>Direction of Airflow</i>	-- 9
<i>Delivery and Storage, Inspection, Damage, and Shortage</i>	-- 10
<i>Lifting Weights, Moving the AHU</i>	-- 11
<i>Rigging</i>	-- 12
<i>Using Fork Lift in Special Circumstances, Come-a-longs, Proper Lifting with Shackles</i>	-- 13
Section 3: Handling, Storage, and Installation	10
<i>Tools Required to Install AHU, Shipped Loose Parts</i>	-- 16
<i>Installing Indoor AHU</i>	-- 19
<i>Back Draft Dampers for Dual Fans</i>	-- 27
<i>Filling Inertia Fan Base, Steam Humidifier, UVC Emitter Lamps</i>	-- 28
<i>Air Measuring Device Connections</i>	-- 32
<i>Condensate Drain Arrangement</i>	-- 33
<i>Field Penetrations for Piping and Electrical Connections</i>	-- 34
<i>General Electrical Information, Power Connections</i>	-- 36
<i>Wiring the Energy Recovery Wheel, Wiring the Gas Heat Device</i>	-- 38
<i>Wiring the Electric Heat Device</i>	-- 39
<i>Electric Humidifier, Humidifier</i>	-- 42
<i>Lights for AHUs, Piping Connections, and Coil Piping</i>	-- 43
<i>Water Treatment</i>	-- 46
<i>Vertical Tube Integral Face and Bypass (VIFB) and Integral Face and Bypass (IFB)</i>	-- 49
<i>Refrigeration (DX)</i>	-- 53
<i>Thermostatic Expansion Valves (TXV), Hot Gas Bypass (HGBP)</i>	-- 56
<i>DX Coil Circuiting and Staging</i>	-- 57
<i>Maintaining Adequate Airflow, VAV Systems</i>	-- 58
<i>Drains and Traps</i>	-- 59
<i>Duct Connections</i>	-- 60
<i>Air Filters</i>	-- 62
<i>Conversions, Temperature</i>	-- 70

IMPORTANT!

READ BEFORE PROCEEDING!

GENERAL SAFETY GUIDELINES

This equipment is a relatively complicated apparatus. During installation, operation maintenance or service, individuals may be exposed to certain components or conditions including, but not limited to: refrigerants, UV, materials under pressure, rotating components, and both high and low voltage. Each of these items has the potential, if misused or handled improperly, to cause bodily injury or death. It is the obligation and responsibility of operating/service personnel to identify and recognize these inherent hazards, protect themselves, and proceed safely in completing their tasks. Failure to comply with any of these requirements could result in serious damage to the equipment and the property in which it is situated, as well as severe personal injury or death to themselves and people at the site.

This document is intended for use by owner-authorized operating/service personnel. It is expected that these individuals possess independent training that will enable them to perform their assigned tasks properly and safely. It is essential that, prior to performing any task on this equipment, this individual shall have read and understood this document and any referenced materials. This IOM is only a supplement to all included vendor IOMs. This is not inclusive. This individual shall also be familiar with and comply with all applicable governmental standards and regulations pertaining to the task in question.

SAFETY SYMBOLS

The following symbols are used in this document to alert the reader to specific situations:



DANGER - Indicates a possible hazardous situation which will result in death or serious injury if proper care is not taken.



WARNING - Indicates a potentially hazardous situation which will result in possible injuries or damage to equipment if proper care is not taken.



CAUTION - Identifies a hazard which could lead to damage to the machine, damage to other equipment and/or environmental pollution if proper care is not taken or instructions are not followed.



NOTE - Highlights additional information useful to the technician in completing the work being performed properly.



WARNING - External wiring, unless specified as an optional connection in the manufacturer's product line, is not to be connected inside the control cabinet. Devices such as relays, switches, transducers and controls and any external wiring must not be installed inside the micro panel. All wiring must be in accordance with Krueger's published specifications and must be performed only by a qualified electrician. Krueger will NOT be responsible for damage/problems resulting from improper connections to the controls or application of improper control signals. Failure to follow this warning will void the manufacturer's warranty and cause serious damage to property or personal injury.

SECTION 1 - GENERAL INFORMATION & SAFETY

INTRODUCTION

Krueger's air handling unit (AHU) is manufactured to the highest design and construction standards to ensure high performance, reliability and adaptability to all types of air handling installations.

ABOUT THIS MANUAL

This manual and any other document supplied with the AHU are the property of Krueger, which reserves all rights. This manual may not be reproduced, in whole or in part, without prior written authorization from an authorized Krueger representative.

In addition, this manual:

- Includes suggested best working practices and procedures, which are issued for guidance only, and they do not take precedence over the above stated individual responsibility and/or local safety regulations.
- Contains all the information required for correct installation and commissioning of the AHU, together with operating and maintenance instructions.
- Should be read thoroughly before attempting to operate or service the AHU.
- Contains detailed procedures, including installation, commissioning, and maintenance tasks that must only be performed by suitably trained and qualified personnel.

The manufacturer will not be liable for any injury or damage caused by incorrect installation, commissioning, operation, or maintenance resulting from a failure to follow the procedures and instructions detailed in the manual.

RESPONSIBILITY FOR SAFETY

Every care has been taken in the design and manufacture of the AHU to ensure compliance with the safety requirements. However, the individual operating or working on any equipment is primarily responsible for:

- Personal safety, safety of other personnel, and the equipment.
- Correct utilization of the equipment in accordance with the procedures detailed in this manual.

WARRANTY

Krueger warrants AHUs in accordance with the Limited Warranty. See Krueger's website for more information.

Krueger warrants all equipment and materials against defects in workmanship and materials for a period of 18 months from the date of shipment or 12 months from the date of start-up, whichever comes first.

The warranty is limited to parts only replacement and shipping of any faulty part, or subassembly, which has failed due to defects in workmanship and materials. All claims must be supported by evidence that the failure has occurred within the warranty period, and that the AHU was operated within the designed parameters specified.

All warranty claims must specify the AHU model, serial number, order number, and run hours/starts. Model and serial number information is printed on the AHU identification plate.

The AHU warranty will be void if any modification to the AHU is carried out without prior written approval from Krueger. For warranty purposes, the following conditions must be satisfied:

- Only genuine Krueger approved spare parts must be used.
- All of the scheduled maintenance operations detailed in this manual must be performed at the specified times by suitably trained and qualified personnel.
- Failure to satisfy any of these conditions will automatically void the warranty. Refer to Krueger's website for details on the Limited Warranty.

SECTION 2 - PRODUCT DESCRIPTION

The AHU features segmented construction and is factory assembled. Segment arrangements will vary to suit the job application as shown in Figure 1 on the next page.

Features of the AHU include:

- Heavy gauge galvanized steel is used on the exterior and interior of the AHU.
- Access doors are provided for accessibility to the various sections.
- Panels and doors are constructed with double walls.
- Panels, doors, and structural frame are insulated with spray-injected foam.

TYPICAL AHU OPERATION

The operation of the AHU is divided into five systems:

1. Ventilation
2. Economizer (Return Air/Mixing Box Section)
3. Heating
4. Cooling
5. Cleaning

Ventilation System

The purpose of a ventilation system is to remove air that is substandard to create comfort or a process, and replace it with suitable air. Depending on the application, the system will operate at various specified rates, volumes, and conditions. A ventilation system may employ an AHU with a supply fan working in conjunction with a remote exhaust fan(s). A more effective method would employ a supply fan and an exhaust fan in the AHU.

Economizer System (Typical)

The economizer system typically consists of:

- Outdoor and return air dampers
- Damper actuator
- Enthalpy control
- Minimum outdoor air adjustment
- Exhaust air control

The economizer system provides the first stage of cooling whenever the outdoor air is cool and dry enough to satisfy the internal cooling demand. The outdoor and the return air dampers are operated by individual actuators. As the outdoor air dampers are opened by the damper actuator, the return air dampers are closed.

Heating and Cooling System

Various types of heating and cooling may be applied, which include:

- Hot water or steam coils
- Electric or fuel burner heat
- Factory mounted chilled water coils
- Direct expansion refrigerant coils

CLEANING

Various types of cleaning include filters and UV lights.

HAND ORIENTATION

Coil connections and other components are located and described as left or right hand. The proper orientation to describe the proper hand is when airflow is at your back as shown in Figure 2 on the next page.

AHU

IDENTIFICATION (ID)

AHUs are labeled with the following ID labels:

- AHU
- Skid
- Loose components

AHUs are shrink wrapped with skid ID labels on the outside of the wrapping and on each skid.

SECTION 2 - PRODUCT DESCRIPTION (CONTINUED)

FIGURE 1 - CUTAWAY OF AHU SHOWING SEGMENTED CONSTRUCTION

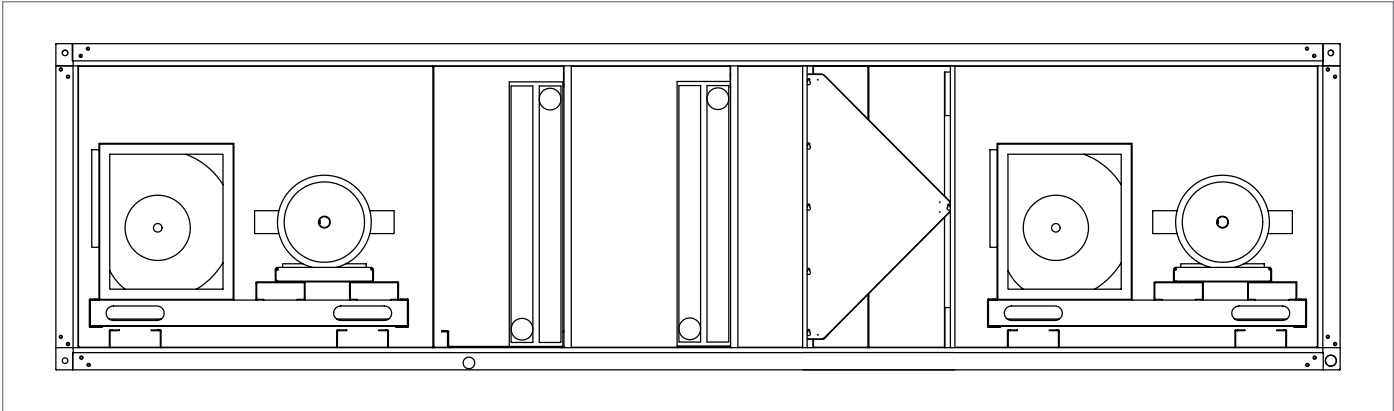
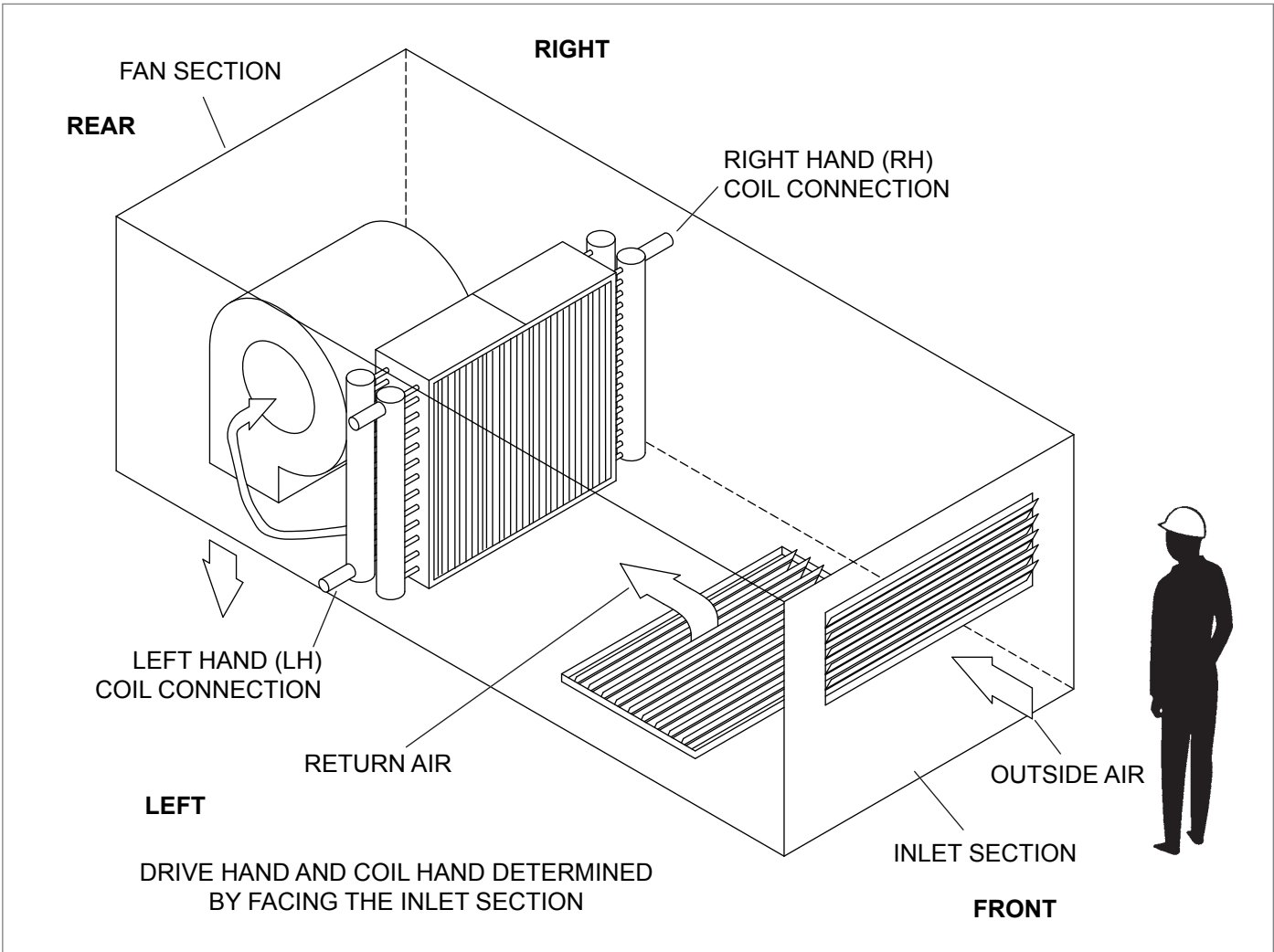

FIGURE 2 - AHU AND COIL HAND IDENTIFICATION



SECTION 2 - PRODUCT DESCRIPTION (CONTINUED)

AHU ID Label

The AHU ID label contains the following information as shown in Figure 3 (below):

- Model Number
- Serial Number/Date Code
- Job ID Number
- Segment ID Number
- Number of Skids
- AHU Tag Number
- Electrical Ratings
- Coil Data
- Manufacturing Location

Skid ID Label

Each skid in a multi-piece AHU is marked with a skid ID label, which indicates its order of assembly in the direction of airflow as shown in Figure 4 (below).

Segment ID Box

The segment ID box indicates the skids and segments used on a multi-piece AHU. The contents of each skid are indicated by the segment(s) surrounded by parentheses as shown in Figure 5 (below). Refer to Table 1 on the next page for the segment definitions.

FIGURE 3 - AHU ID LABEL

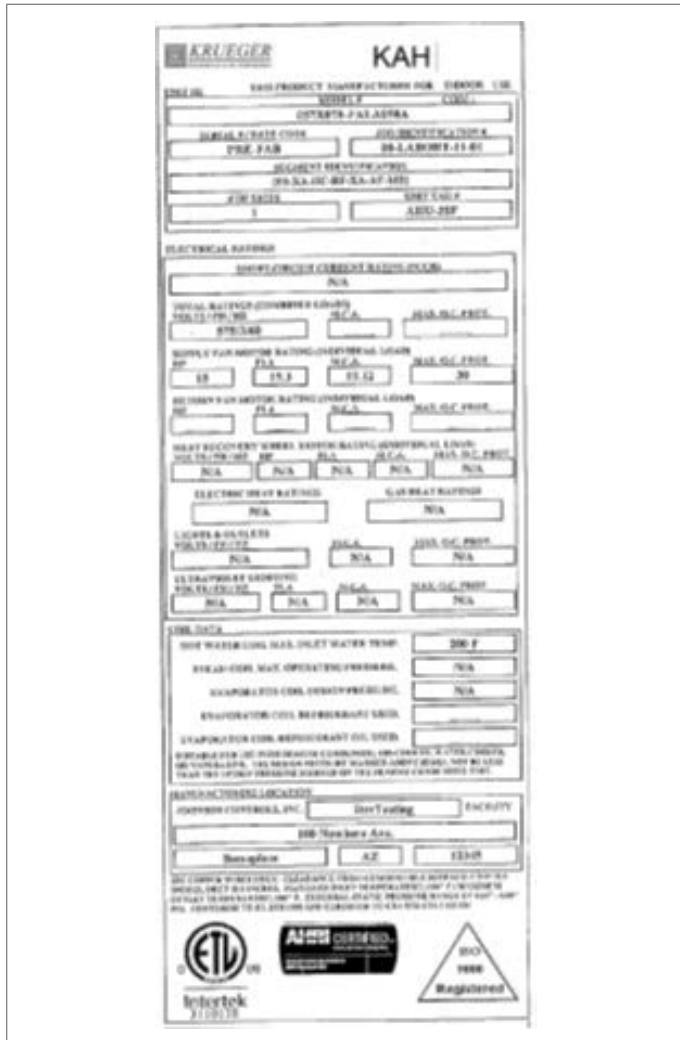
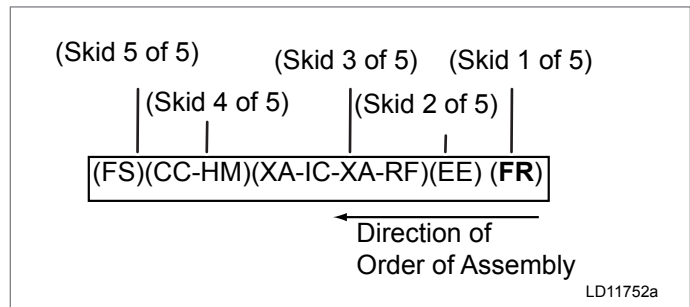

FIGURE 4 - SKID ID LABEL



FIGURE 5 - EXAMPLE OF SEGMENT ID BOX



SECTION 2 - PRODUCT DESCRIPTION (CONTINUED)

TABLE 1 - DEFINITION OF SEGMENT IDS

FAN SEGMENTS	
FS – Supply	Forward Curved DWDI
	Airfoil DWDI
	Industrial Airfoil DWDI
	SWSI Airfoil Plenum (Belt and Direct Drive)
FR – Return	Forward Curved DWDI
	Airfoil DWDI
	Industrial Airfoil DWDI
	SWSI Airfoil Plenum (Belt and Direct Drive)
FE – Exhaust	Forward Curved DWDI
	Airfoil DWDI
	Industrial Airfoil DWDI
	SWSI Airfoil Plenum (Belt and Direct Drive)
COIL SEGMENTS	
CC – Cooling Coil	VC – Vertical Coil
HC – Heating Coil	MZ – Multi-Zone
HEAT SEGMENTS	
IC – Integral Face & Bypass Coil	EH – Electric Heater
IG – Indirect Gas Fired Furnace	
ENERGY RECOVERY	
ER – Heat Wheel	HW – Heat Wheel
FILTER SEGMENTS	
FF – Flat Filter (2" or 4")	AF – Angle Filter (2" or 4")
RF – High Efficiency Filter	Rigid Filter (12")
	Bag Filter (21")
	Mini-Pleat Filter (4")
INLET SEGMENTS	
MB – Mixing Box	IP – Inlet Plenum
FM – Filter / Mixing Box	VE – Vertical Economizer
EF – Filter / Economizer	VF – Vertical Filter / Economizer
EE – Economizer	IO – Inlet / Outlet
ACCESSORY SEGMENTS	
VP – Vertical Plenum	EB – External Bypass
DP – Discharge Plenum	IB – Internal Bypass
TN – Turning Plenum	FD – Face Damper
DI – Diffuser	HM – Humidifier
XA – Access Segment	AT – Sound Attenuator
AB – Air Blender	UV – UV Lights

Shipped Loose Parts

Each loose component has a label to show where it should be installed on the AHU. The segment ID box on the label will show the skid on which it is to be installed. If the loose component is used in only one segment on a skid, the segment ID will be bold. Figure 6 (below) shows a typical filter label.

FIGURE 6 - FILTER ID LABEL

DIRECTION OF AIRFLOW

The direction of airflow is always read from right to left.

SECTION 3 - HANDLING, STORAGE, & INSTALLATION

DELIVERY AND STORAGE

To ensure consistent quality and maximum reliability, all AHUs are tested and inspected before leaving the factory.



CAUTION - Under no circumstances should outdoor storage be used. Remove the ventilate wrapping to prevent condensation.

Short Term

Short term storage is six months or less from date of shipment. Storage maintenance during this time is usually limited to the following:

- Rotate fans every four weeks, starting on the delivery date to prevent moisture from damaging the bearing.
- If the AHUs are going to be stored out-of-doors prior to installation, special care must be taken to cover and protect the AHUs from:
 - » Dust, rain, snow, and rodents
 - » Construction vehicles and personnel
 - » Condensation / ventilation required
- Protect all parts and porous materials from rain and other sources of moisture. Decontaminate or replace parts as needed to make sure microbial growth is not introduced to the AHU.
- Store the AHU on a firm, flat surface to prevent distortion. Block the AHU off the ground to protect components from water or ground moisture.

Long Term

Long term storage is more than six months from the date of shipment. If long term storage is anticipated, contact the Krueger sales representative for the proper instructions and requirements.

It is mandatory that a detailed record be maintained during this long term period, such as, but not limited to the following:

- Proper sealing of the cabinet,
- Rotation of the blowers and bearings, and
- Protection of all motors from moisture.

Refer to Long Term Storage Requirement - Field Preparation form and Long Term Storage Periodic Checklist and Logs form for more information.

INSPECTION, DAMAGE, AND SHORTAGE

Check the AHU shipment on arrival to make sure that all major pieces, boxes, and crates are received. Check each AHU on the trailer or rail car when received, before unloading, for any visible signs of damage. Report any damage or signs of possible damage to the transportation company immediately for its inspection.

After inspecting the AHU for damage, open all containers and check the contents against the packing list. Report any material shortage to Krueger immediately.



NOTE - KRUEGER WILL NOT BE RESPONSIBLE FOR ANY DAMAGE OR LOSS OF PARTS IN SHIPMENT OR AT JOB SITE. Refer to Shipping Damage Claims form.

Preventive Maintenance Prior to Long Term Storage

Take the following precautions prior to extended storage:

- Grease the fan and motor bearings per the manufacturer's specifications.
- Protect the motors and sheaves from moisture or high humidity, which may be accomplished by:
 - » Spraying components with an anti-rust solution (P/N 026-37707-000).
 - » Disconnecting the belts. Wrapping the sheaves and motor and sealing them with plastic. Inserting a desiccant to absorb moisture that may penetrate the plastic protection.
- Meg the fan motor windings and record for comparison prior to placing the AHU in service.
- If the fan housing was supplied with a drain connection, remove the plug to prevent moisture from accumulating in this part of the fan during storage.

Periodic Fan Check

On a monthly basis, perform the following tasks:

- Rotate the fan and motor several times to replenish the bearing surfaces with fresh grease.
- Turn the fan impeller 180° from the previous month's position to prevent the belts from taking a set position.

SECTION 3 - HANDLING, STORAGE, & INSTALLATION (CONTINUED)

Monthly Log Sheet

It is the customer's responsibility to submit a monthly log sheet from the Long Term Storage Periodic Checklist and Logs form that shows the condition of the AHU and to note any discrepancies. Send a copy of the log sheet to the local Krueger Representative for their records.



CAUTION - Failure to fulfill the long term storage requirements will void the warranty.

Receiver's Responsibility

The receiver is solely responsible for noting the freight bill and filling out the freight claims IMMEDIATELY. In addition, the receiver must:

- Note the visible damage on the signed and dated bill of lading with a request that the carrier inspect the damage within 72 hours of notification.
- Remove the shipping wrapper, and replace it with a tarp or similar protective covering. Any concealed damage reported after 15 days will compromise a claim settlement.
- Request inspections by telephone or in person, but confirm in writing. If assistance is needed with the claim process, contact a Krueger sales representative and refer to the Shipping Damage Claims form.

Check Doors and Latches

Refer to the Service Manual for adjusting and replacing the doors.

The AHU doors are shipped with metal shipping spacers glued onto the edges of each door. They are located on three edges of each door. The spacers should be left in place until the AHU is placed in its final location and multiple skid AHUs are fully assembled. After AHU installation use a channel lock pliers or a screwdriver to remove the spacers. Do not damage the metal door panel. Slight impressions left on the door gasket by the spacers will rebound in approximately a week.

FIGURE 7 - METAL SPACERS ON DOORS



Indoor AHUs

It is Krueger's intention that a shipping wrapper be applied to unpainted indoor AHUs for protection from weather, road dirt, etc. during inland transit. Remove the wrapper at the time of delivery to allow for a thorough inspection, both inside and out. Under no circumstances should outdoor storage be used.

Access - All AHU doors have a small clip, which is located on the door frame, and crosses over the edge of the door. This clip is a safety device to prevent injury when the AHU is operating. Remove the clip to inspect the AHU and replace it when inspection is completed.

If the AHU is covered with plastic, cut the wrap in the outline of the door(s) and proceed to access the AHU using the information (above). Close the cut with duct tape.

Shipped Loose Parts

Check the packing list, which notes the number and types of parts, for non-mounted shipped loose parts in all segments of the AHU. Report shortages within 10 days after receipt of the order. For more information about the shipped loose parts, refer to Figures 20-28 on pages 16-18.

LIFTING WEIGHTS

AHU section weights are furnished on the job submittal form. Due to the variance in weight of each AHU design, it is not possible to list AHU weights in these instructions. Refer to the job submittal form when selecting a crane for rigging and figuring out roof weight loads. Weights can also be found on skid ID label for each section. Contact a Krueger sales representative if there are questions regarding the AHU weights.

MOVING THE AHU

Prior to moving the AHU, make sure that the installation site is suitable for installing the AHU and that it is easily capable of supporting the weight of the AHU and all associated services.

SECTION 3 - HANDLING, STORAGE, & INSTALLATION (CONTINUED)

FIGURE 8 - RIGGING WARNING LABEL



WARNING

Failure to follow these instructions could result in death, serious injury or equipment damage.

Follow all warnings and instructions in the unit's Manual(s).

<p>EN Installation Instructions for the technician / fitter</p> <p>PL Instrukcja instalacji dla technika / monter</p> <p>SV Installationsguide för installatör / montör</p> <p>CS Pokyny k instalaci pro techniky a montéry</p>	<p>IT Istruzioni d'installazione per il personale specializzato</p> <p>NL Installatiehandleiding voor de vakman / monteur</p> <p>DE Installationsanleitung für die Fachkraft / Monteur</p> <p>ES Instrucciones de instalación para el técnico / contratista especializado</p>	<p>JA 一般仕様・取扱説明書</p> <p>FR Manuel d'installation pour le spécialiste / monteur</p> <p>RU Инструкция по установке для техника/монтажника</p> <p>ZH 适用于技术人员与安装人员的 安装说明书</p>	
---	---	---	---

1. Follow all applicable regulations and safety practices during rigging and lifting.
2. Prepare and follow written rigging and lifting plan.
3. Rigging must be directed by trained professional rigger.
4. Spreader bars must be used and be long enough to prevent rigging from contacting unit.
5. Use all and only designated lift points according to units manual(s).
6. Locate center of gravity through trial lifts to account for possible variations in unit configuration.
7. Use rigging and lifting techniques that keep unit stable and level.
8. Keep clear of unit when lifted.

035-23962-000 REV A

RIGGING

Some AHUs are shipped completely assembled. When large AHUs are ordered with multi-zone (MZ) segments in rear discharge location (end of the AHU), the AHUs will ship with the top section (hot deck) separated. In these cases, the complete MZ damper assembly (hot and cold decks) will ship loose.

 **WARNING** - All lifting points must be used to avoid personal injury, death, or damage to the equipment.

Use all lifting lugs to avoid damage to the AHU. If the AHU is not equipped with lifting lugs, use bottom corner connectors as shown in Figure 11 on the next page and raceway lifting lugs as shown in Figure 12 on the next page. Do not use top corner connectors. Use come-alongs as shown in Figure 10 on the next page.

An experienced and reliable rigger must handle the unloading and final placement of the AHU, and must be advised of the following:

- AHU contains internal components and should be handled in an upright position.
- Care must be exercised to avoid twisting the equipment structure.
- Prevent unnecessary jarring or rough handling.

 **NOTE** - Proper rigging and handling of the equipment is mandatory during unloading and setting it into position to prevent voiding the warranty.

Use the proper spreader bars and hoisting lines when rigging to prevent damage to the AHU casing as shown in Figure 9 (right).

When lifting long AHUs, a special system must be used to insure a minimum 60° angle between the lifting lugs and spreader bar/frame.

SECTION 3 - HANDLING, STORAGE, & INSTALLATION (CONTINUED)

USING FORK LIFT IN SPECIAL CIRCUMSTANCES

Forklifts should not be used to off-load AHUs except in special circumstances. If moving an AHU with a fork lift or similar equipment becomes necessary, make sure the lifting forks are long enough to reach from the fork truck to the opposite side and slightly beyond the AHU. Leave the shipping blocks attached to the bottom of the AHU until it is moved to its final location. There is no structural support under the equipment except what is visible from the perimeter.

COME-A-LONGS (POWER PULLS)

If the AHU has multiple sections, use come-a-longs (power pulls) as shown in Figure 10 (right) to pull the sections or skids together.

PROPER LIFTING WITH SHACKLES

Shackles are fastened to a sling or chain, which is used to lift and lower the sections in a tiered AHU. Refer to the following figures for proper lifting:

- FIG. 11 for proper lifting with a hook and shackle at the corners.
- FIG. 12 for proper lifting with a hook and shackle at the lifting lugs.
- FIG. 13 for lifting with a base rail.

FIGURE 9 - RECOMMENDED LIFTING WITH FOUR CORNER POINTS

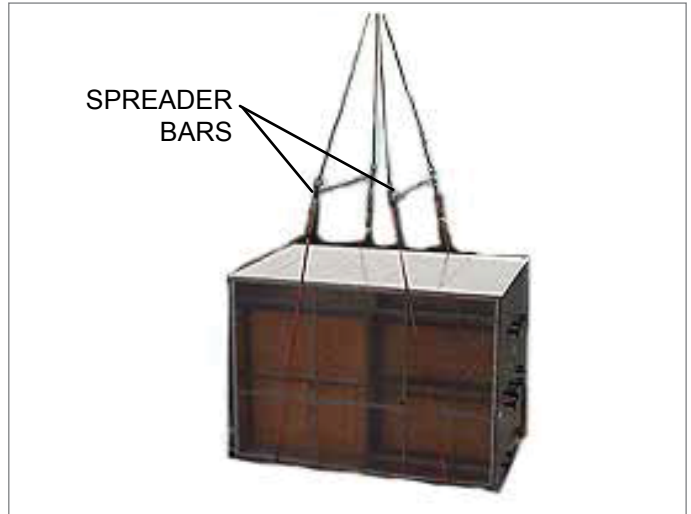

FIGURE 10 - TYPICAL COME-A-LONGS



FIGURE 11 - PROPER LIFTING WITH SHACKLE WITH CORNER CONNECTOR CORNERS



FIGURE 12 - PROPER LIFTING WITH SHACKLE AT LIFTING LUG



FIGURE 13 - PROPER LIFTING WITH BASE RAIL



SECTION 3 - HANDLING, STORAGE, & INSTALLATION (CONTINUED)

PREPARING THE SITE

FIGURE 14 - MINIMUM CLEARANCE DIMENSIONS

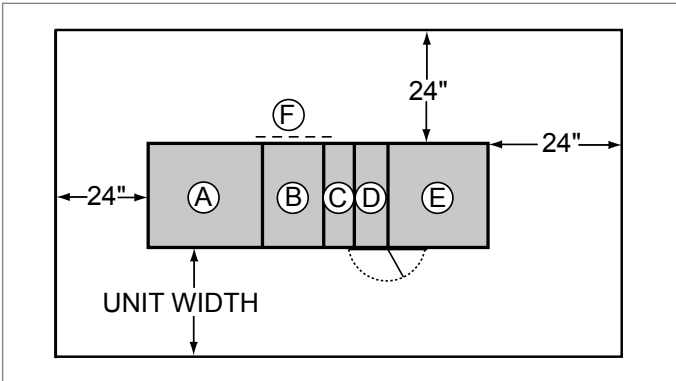

WARNING - Do not weld or use torches on the exterior or interior of the AHU housing. The housing contains polyurethane insulation, which, under combustion, will produce harmful, toxic gases resulting in personal injury or death.



NOTE - Never use silicone caulk/sealant in or on any AHU.

- A - Fan Section
- B - Coil Section
- C - Face and Bypass Damper Section
- D - Filter Section - Door should open 180°
- E - Inlet Section
- F - Coil Access Panel (allow clearance = to unit width)

Clearance and Mounting for Indoor AHUs

It is recommended that the AHU is located in an air-conditioned space. Some suggested installations are shown in Figures 15-17 (below). Make sure the floor and housekeeping pads are flat and level.

Allow sufficient space around the AHU to remove the access panels and various parts. A minimum clearance equal to the width of the AHU plus 6" must be provided on one side of the AHU to remove the coil or fan assembly.

Concrete pads may not be as flat as they should be. Shimming and/or grouting may be necessary. Whether under the AHU base, the AHU base needs to be on a flat plane.

Mounting Indoor AHU

Install the AHUs to provide enough elevation for properly designed condensation traps as discussed in on page 59.

FIGURE 15 - NO BASE RAIL, HOUSEKEEPING PAD REQUIRED TO ACCOMODATE TRAP HEIGHT

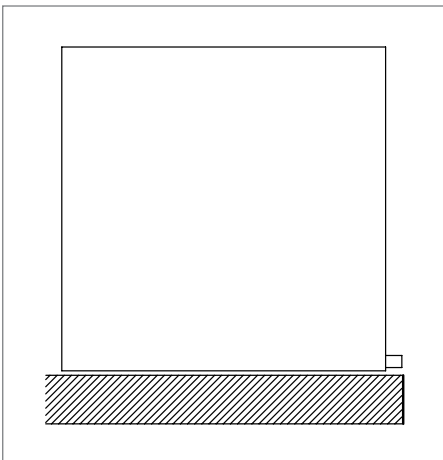

FIGURE 16 - NO HOUSEKEEPING PAD, BASE RAIL REQUIRED TO ACCOMODATE TRAP HEIGHT

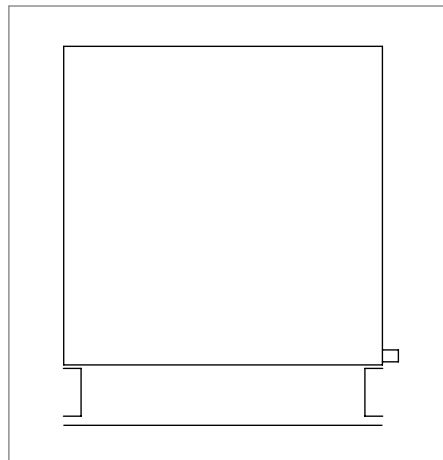
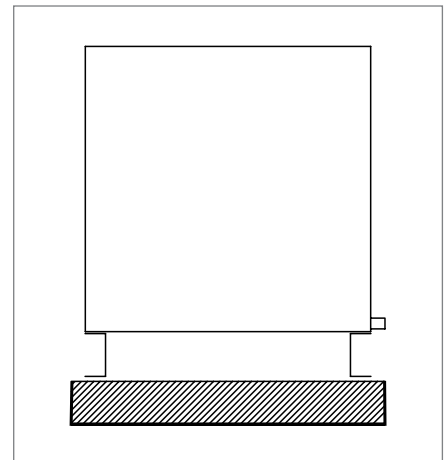

FIGURE 17 - WITH BASE RAIL AND HOUSEKEEPING PAD



SECTION 3 - HANDLING, STORAGE, & INSTALLATION (CONTINUED)

Installing Ceiling Suspended AHUs

! **CAUTION** - It is recommended that support is structurally engineered to prevent flexing, sagging or twisting of the AHUs.

Use the following instructions to prepare the site for ceiling suspended AHUs. Refer to Figure 18 (right), for proper support in the direction of airflow, and/or if the AHU is positioned perpendicular to the direction of the airflow.

Structure Positioned in Direction of Airflow

The AHU base must be supported continuously on both sides.

Structure Positioned Perpendicular to Airflow

The AHUs must be supported (at a minimum) at the following locations:

- Both ends
- At each shipping split, if applicable
- Upstream and downstream of each cooling coil segment
- Under heavy components like fans, attenuators, and heating segment.
- As a general rule, cross members should be placed every 96", in addition to each shipping split.

! **CAUTION** - DO NOT obstruct the door operation, filter access, piping, electrical or control connections with suspension members.

FIGURE 18 - CEILING SUSPENDED AHU

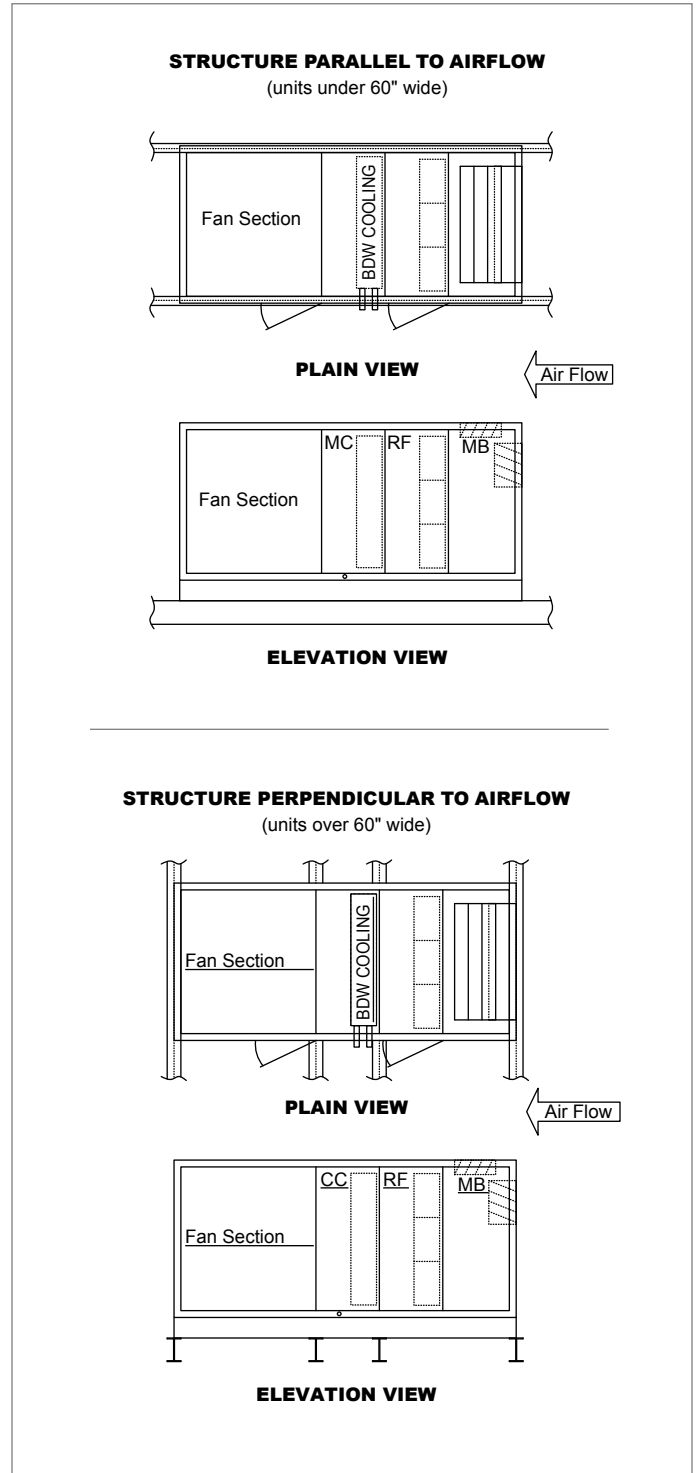

SECTION 3 - HANDLING, STORAGE, & INSTALLATION (CONTINUED)

TOOLS REQUIRED TO INSTALL AHU

The following tools, which are not provided by Krueger, are needed to install the AHU. Refer to Figure 19 (below) for more information.

- Drill with adjustable torque
- No. 3 Phillips bit
- Allen wrench set
- Nut setter or socket set (1/4", 5/16", 3/8", and 9/16")
- Wire cutters
- Come-a-longs (power pulls)
- Slings
- Pry bar
- Drift pins and awls
- Common hand tools
- Caulking gun
- Shackles

FIGURE 19 - TOOLS NEEDED TO ASSEMBLE SHIPPING SPLITS



SHIPPED LOOSE PARTS

The shipped loose parts, which may be required, are shown in Figures 20-28 (below and through page 18). Installation instructions for the shipped loose parts are listed on the Installation Instructions and Ship Loose Items Inside label, located on the access door of the first fan skid in the air stream.

FIGURE 20 - SECOND TIER TIE-DOWN FASTENER PACK (P/N 386-03419-000)

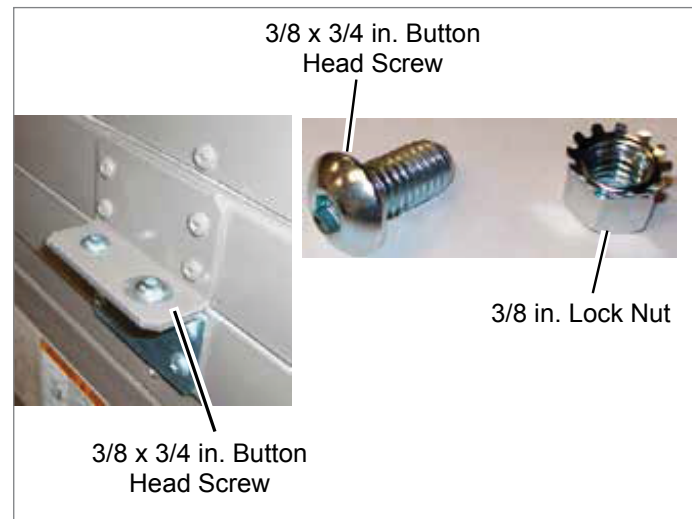
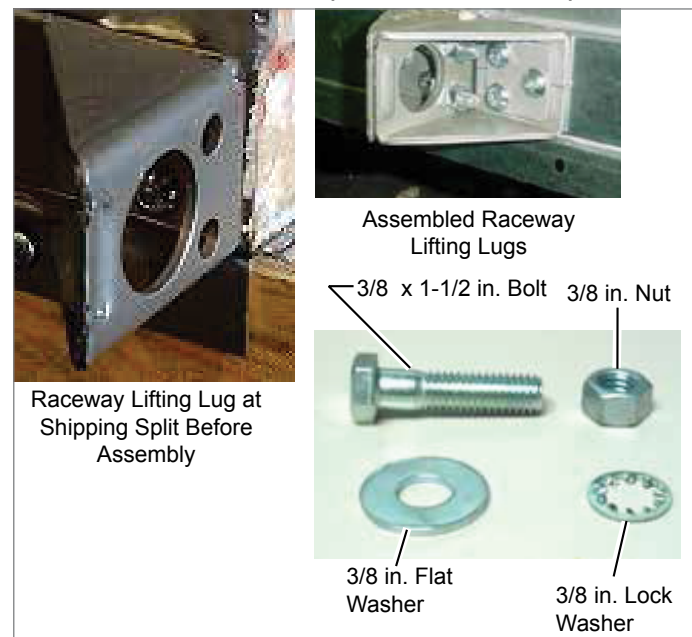

FIGURE 21 - BOTTOM RACEWAY SHIPPING SPLIT FASTENER PACK (P/N 386-03418-000)



SECTION 3 - HANDLING, STORAGE, & INSTALLATION (CONTINUED)

FIGURE 22 - BASE RAIL SHIPPING SPLIT FASTENER PACK (P/N 386-03417-000)

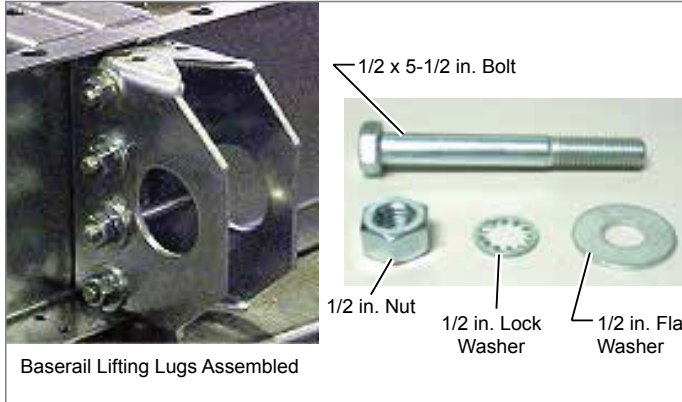

FIGURE 24 - POLYURETHANE CAULK (P/N 021-19568-000 - GREY; P/N 013-03317-040 - CHAMPAGNE)



FIGURE 23 - TOP RACEWAY BRACKET ASSEMBLED (P/N 386-04747-000)



Additional Parts

The following parts may be used later in these instructions.

FIGURE 25 - DAMPER SHAFT EXTENSION KIT (P/N 026-33715-002)

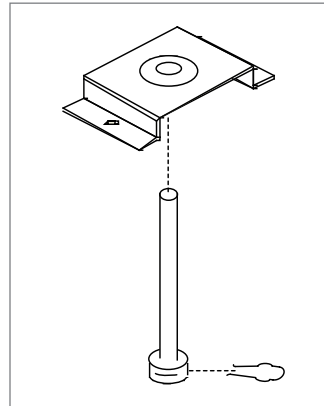

FIGURE 26 - CORNER CONNECTOR HOLE PLUG (P/N 021-19568-000) (8)

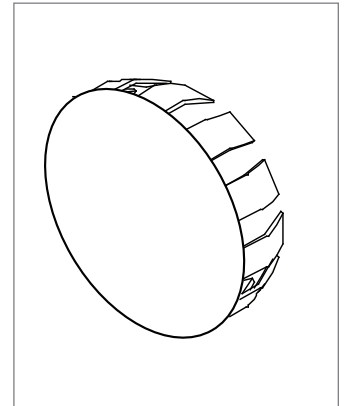

FIGURE 27 - SHIPPING SPLIT CORNER GASKET - 3.5 X 3.5 (P/N 028-11883-010)



SECTION 3 - HANDLING, STORAGE, & INSTALLATION (CONTINUED)

**FIGURE 28 - TOUCH-UP
SPRAY - 12 OZ.
(P/N 013-03322-000)**



**FIGURE 29 - CONDUIT (P/N
025-39024-001) AND SJO
CORD (P/N 025-35746-001)**



FIGURE 30 - SPARE FAN BELT

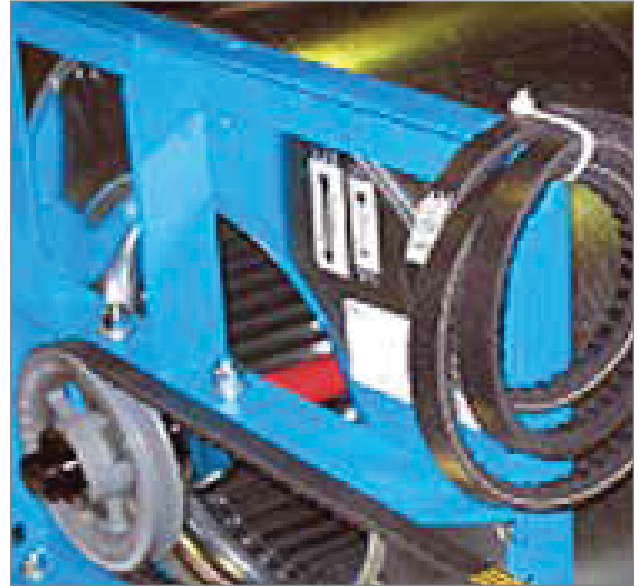
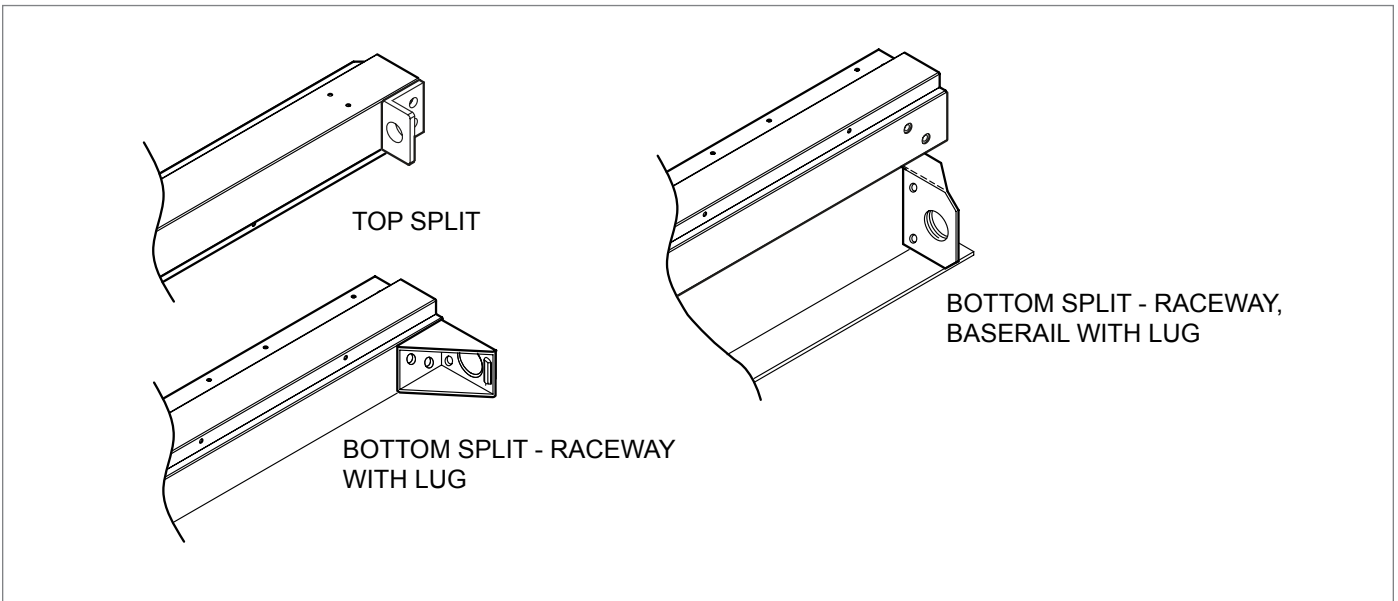

FIGURE 31 - SHIPPING SPLIT EXAMPLES



SECTION 3 - HANDLING, STORAGE, & INSTALLATION (CONTINUED)

INSTALLING INDOOR AHU

Before installing the indoor AHU, identify the shipped loose parts such as gaskets as shown in Figures 20-28 on pages 16-18.



CAUTION - Do not damage factory installed electrical cabinet, pipe stubs, or door handles when installing AHU.



NOTE - If the AHU or AHU sections are too large to fit through an opening, contact the local Krueger Representative for assistance. Technical instructions are available for disassembly and reassembly.

Before placing the skids together:

1. If applicable, remove the metal bracket attached to the cross channel and wood shipping blocks before assembling the shipping splits.
2. If AHU sections are going to be assembled before placing them, be sure the sections are on a flat surface during assembly.
3. Verify the correct sections and orientation of each section.
4. Remove the cross brace(s) (shipping supports) from each section's shipping split.
5. Remove the plastic shipping covers and supports.
6. Apply neoprene gasket (P/N 028-15954-010) to one side only of each shipping split as shown in Figure 32 (right). If there is a door frame at the shipping split, apply neoprene gasket (P/N 028-11873-010) as shown in Figure 33 (right). Make sure the entire perimeter is covered with the gasket material, including the foamed corners as shown in Figure 33 (right). Any void, depression, or protrusion will allow air or water leakage. Make any splices on a straight run.

FIGURE 32 - USE GASKET (P/N 028-11883-010) AT SHIPPING SPLIT

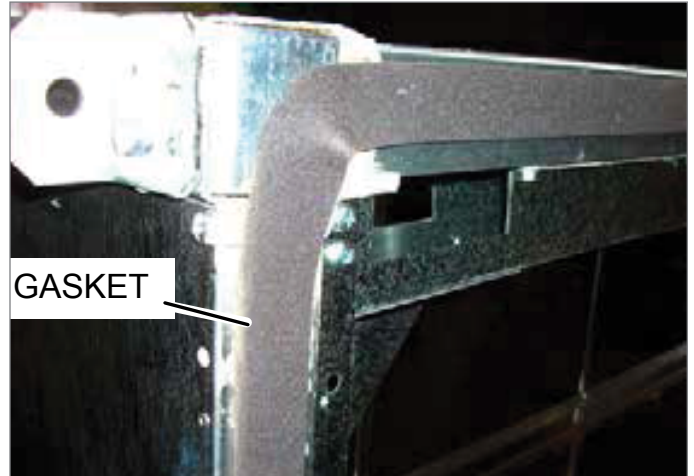
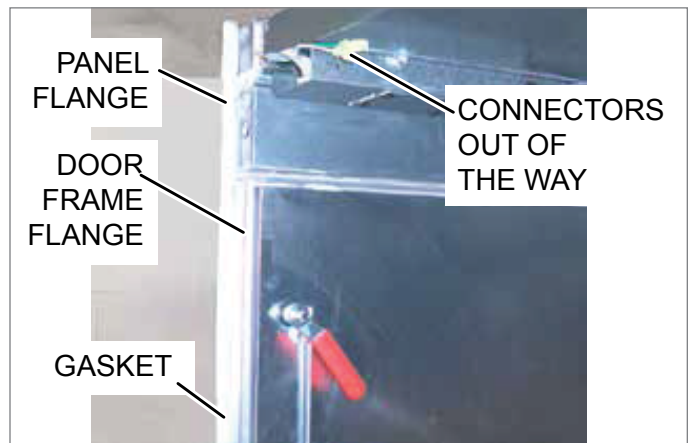

FIGURE 33 - USE GASKET (P/N 028-11873-010) TO DOOR FRAME AT SHIPPING SPLIT



SECTION 3 - HANDLING, STORAGE, & INSTALLATION (CONTINUED)

Setting Up and Pulling Sections Together

Use the following instructions to set up and pull the sections together.

1. Place the first section in its final position and anchor or block it before placing the next section.
2. Attach the come-a-longs to the far end of the next section as shown in Figure 34 (right).



NOTE - Make sure the chain does not apply pressure to the drain connection. Improper positioning of the chain may cause damage to the AHU.

3. Place the next section on the curb about 8" from the first section.
4. Feed the electrical and control connections from section to section and make sure that they will be accessible after the sections are joined as shown in Figure 35 (right).
5. Assemble the electrical connectors and/or pneumatic tubes according to their labels before joining the sections as shown in Figure 36 (right), if access will be a problem later.
6. After making the electrical and control connections, and before proceeding with assembly, remove and reposition the top shipping split angle as shown in Figure 37 on the next page.
7. Attach the come-a-longs to the far end of the first section.
8. Start pulling the sections together. Pull evenly on both sides.
 - a. Make sure all electrical or control wires or tubes are clear.
 - b. Guide the top raceways together by placing rods or drift pins through the holes in the top guide angles. When the raceways are together, install the long bolts provided as shown in Figure 38 on the next page.
 - c. Guide the bottom raceway/base rails together, using rods or drift pins through the holes in the lifting lugs on opposite sections simultaneously.
 - d. If there is any difficulty aligning the sections, due to racking of one section or the other, use a come-a-long diagonally on the inside of that section at the shipping split or across the tops of the opposite sections.
 - e. If there is any difficulty aligning the sections due to the top and bottom not pulling together simultaneously, apply shims under the sections as needed to compensate for uneven placement area.

FIGURE 34 - COME-A-LONG ATTACHED TO A SECTION

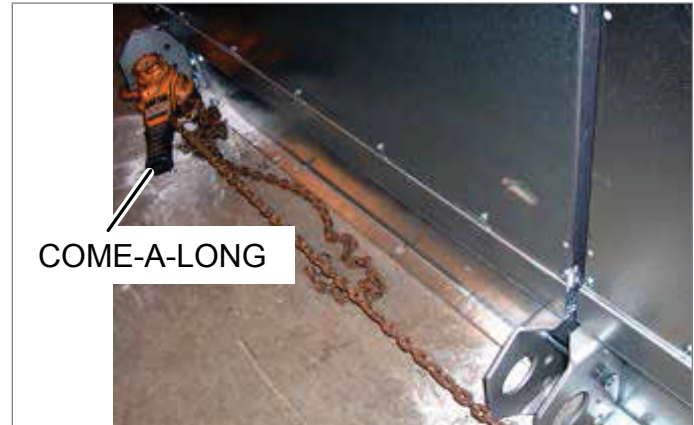

FIGURE 35 - ELECTRICAL CONNECTOR (NOT CONNECTED)

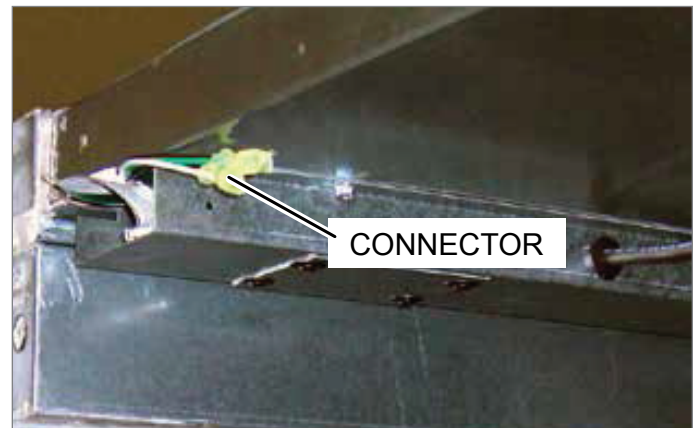
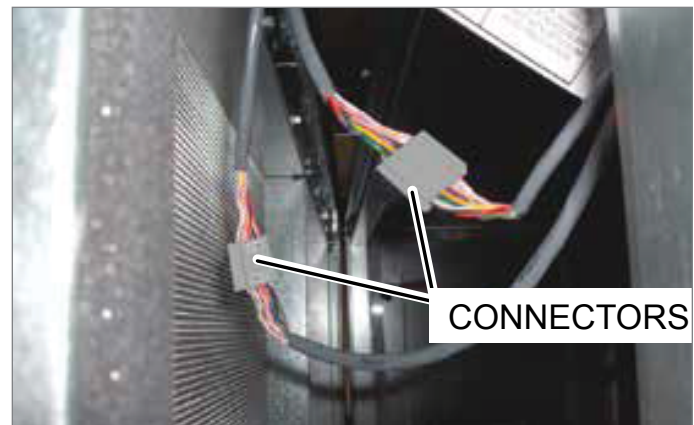

FIGURE 36 - ELECTRICAL CONNECTORS (CONNECTED)



SECTION 3 - HANDLING, STORAGE, & INSTALLATION (CONTINUED)

9. Complete pulling the sections together, using the come-a-longs. The bolts hold the sections tight after they are pulled together.
10. Fasten the bottom lifting lugs together with the 1/2" x 5 1/2" bolts in fastener packet (P/N 386-03418-000) as shown in Figure 39 (right).
11. Fasten the top raceway bracket with the 1/2" x 5 1/2" bolts in fastener packet (P/N 386-03418-000).
12. Apply neoprene gasket (P/N 028-15954-010) to the underside of the seam caps, and install them over the joints with hex head screws (P/N 386- 04747-000) as shown in Figure 40 (right).
13. Repeat this procedure for each additional section.
14. For AHUs or sections without base rails, install the corner connector hole plugs (P/N 021-19568-000) as shown in Figure 41 (right) on the bottom raceway corners.

FIGURE 38 - BRING SHIPPING SPLITS TOGETHER



FIGURE 39 - FASTEN BOTTOM LIFTING LUGS

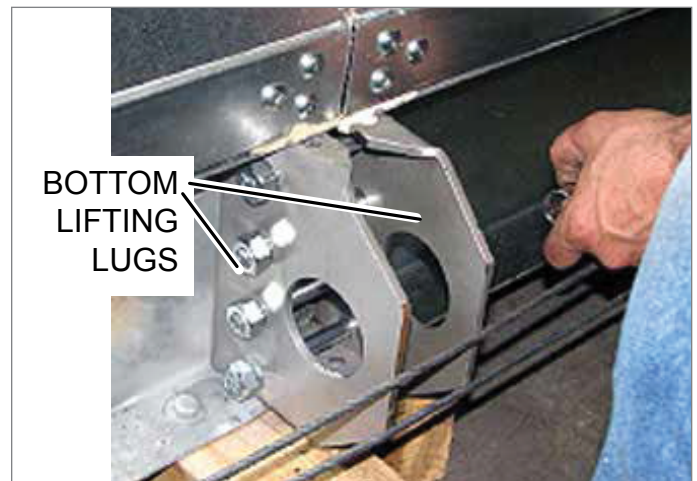

FIGURE 37 - REMOVE AND REPOSITION SHIPPING SPLIT ANGLE



FIGURE 40 - INSTALLING GASKETS



FIGURE 41 - CORNER CONNECTOR HOLE PLUG (P/N 021-19568-000)

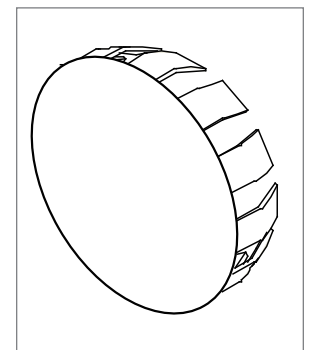

SECTION 3 - HANDLING, STORAGE, & INSTALLATION (CONTINUED)

Installing a Tiered AHU

A tiered AHU, as shown in Figure 42 (right), may not be factory assembled. Field assembled AHUs are shipped with the top tier segment skidded.

This top-tier segment is equipped with brackets bolted to the bottom raceway as shown in Figure 43 (right). The bottom-tier segment is equipped with brackets bolted to the top raceway, and are used to secure the top segment to the bottom segment.

After final alignment, bolt the two brackets with the hardware supplied fastener pack (P/N 386-03419-000) as shown in Figure 43 (right).

1. Verify the correct sections and orientation of the top and bottom tiers.
2. Remove cross brace(s) (shipping supports) from the top tier.
3. Remove the plastic shipping covers and supports.
4. Make sure all wiring and/or control tubing connection pigtails are secured out of the path of the mating surfaces to prevent damage during rigging.
5. Make sure the neoprene gasket (P/N 028-15954-010) is properly installed on the bottom tier. If the top tier is shorter in the direction of airflow than the bottom tier, apply the gasket material on the top panel of the bottom tier from raceway to raceway, but not on top of the raceways as shown in Figure 44 (right).
6. Apply the second layer of gasket (P/N 028-15954-010) over top of the gasket applied in Step 5, but include the raceways. Steps 5 and 6 are necessary because the top panel of the bottom tier is slightly recessed below the height of its raceways.
7. If the top tier has shipping splits, refer to Installing Indoor AHU on page 19 for the correct assembly procedure.

CAUTION - Make sure all of the electrical or control wires or tubes in both tiers are clear.

8. Install four shackles, one in each bottom corner connector or raceway lifting lug. Refer to the proper lifting procedure for the specific shackles under Proper Lifting with Shackles on page 13.
9. Fasten the sling/chain to the shackles and the other end of the sling/chain to the spreader bar (as needed).
10. Lift the top tier assembly with a crane or overhead lift.

FIGURE 42 - TIERED AHU



Figure 43 - SECOND TIER TIE-DOWN FASTENER PACK (P/N 386-03419-000)

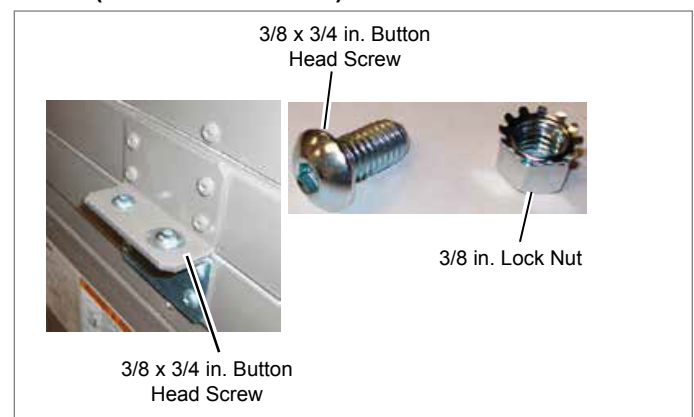
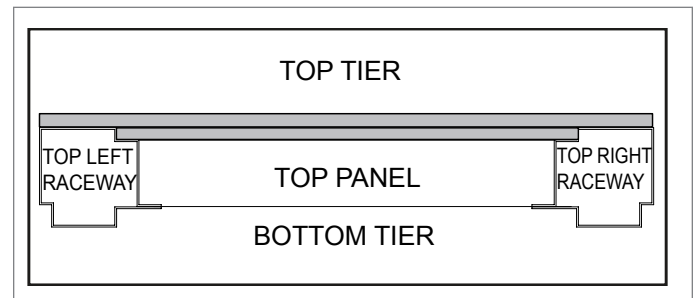

FIGURE 44 - APPLY GASKETS TO TOP PANEL ON BOTTOM TIER



11. Feed the electrical and control connections from the top tier to bottom tier, and make sure that they will be accessible after the sections are joined. If any connections will not be accessible, assemble the electrical connectors and/or pneumatic tubes according to the labels before joining the top and bottom tiers.

SECTION 3 - HANDLING, STORAGE, & INSTALLATION (CONTINUED)

12. Lower the top tier onto bottom tier so that mounting brackets mate. Guide the brackets together, using rods or drift pins through the bolt holes as shown in Figure 45 (right).

FIGURE 45 - GUIDE BRACKETS TOGETHER



13. Carefully place each section of the top tier without disturbing the gaskets on the bottom tier. Secure the top tier to bottom tier with 3/8" x 0.75" allen head bolts.

14. Install the corner connector hole plugs (P/N 021-19568-000) as shown in Figure 41 on page 21 onto the bottom raceway corners.

Lights for Tiered AHU (If Applicable)

If the AHU is equipped with lights, the following parts are shipped loose on a tiered unit, as shown in Figure 46 (below).

- Conduit (P/N 025-39024-001)
- SJO Cord (P/N 025-35746-01)

FIGURE 46 - LIGHTS TIER TRANSITION DRAWING

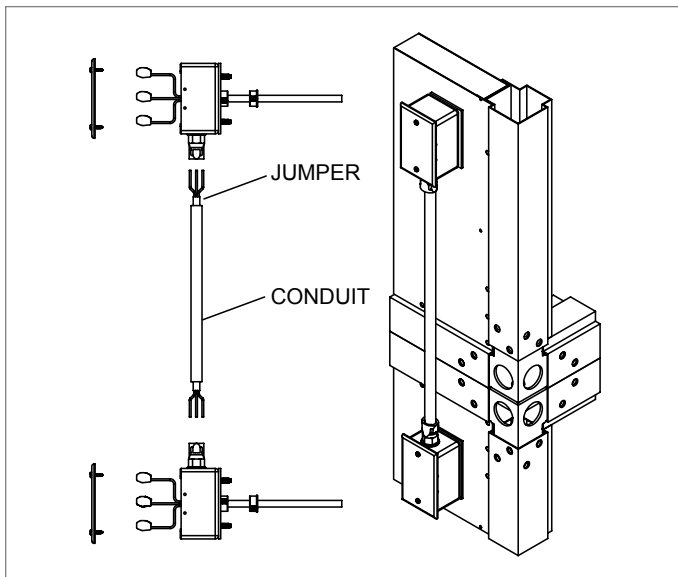

Assembling the AHU End Channel Shipping Split



NOTE - The assembly is the same regardless which sections are connected together.

Use the following instructions to prepare the sections before they are attached.

1. Remove the shipping brackets in the corners.
2. Clean the metal surface where gasket is to be applied with mineral denatured alcohol or rubbing alcohol.
3. Apply the neoprene gasket to all raceway mating surfaces of each section. On large AHUs, install two gaskets side by side on the intermediate raceway surfaces.
4. Make sure that the sections are not racked, and will line up properly.
5. Attach the sections as follows:
 - a. Make sure assembly surface is clean and level to allow the sections to slide freely. If the surface is irregular, use metal shims under sections as necessary to align mating surfaces.
 - b. Pull the sections together using a come-along, drawing the base together.
 - c. Attach the sides of the sections. Beginning at the bottom of the sections, secure the end channel assembly brackets together using fastener pack (P/N 386-03419-000) at each bracket. Continue securing the end channel assembly brackets together, working from bottom to top, pulling the sections tight.
 - d. After the sides are secured, secure the brackets on top of the AHU with the same hardware removed in Step 4.

SECTION 3 - HANDLING, STORAGE, & INSTALLATION (CONTINUED)

FIGURE 47 - ASSEMBLING THE END CHANNEL SHIPPING SPLIT WITH ENERGY RECOVERY WHEEL

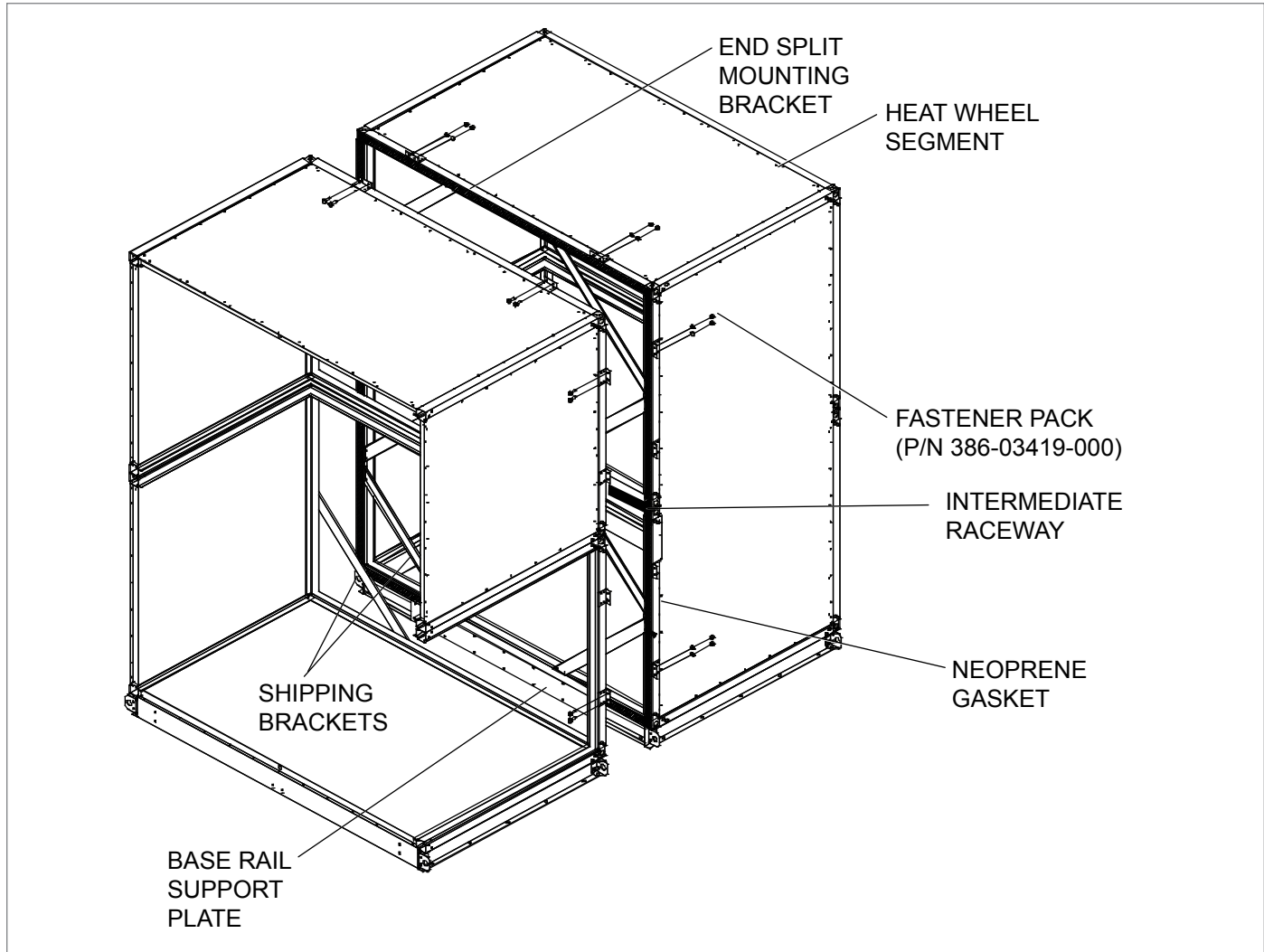

Installing Damper Actuator

Use the following instructions to install the actuator as shown in Figure 48 on the next page.

Damper Blade Orientation

Return Air and Mixing Dampers:

Position blades so that they will be open once the actuator is installed. This will be the dampers spring return position. Note whether the damper shaft is rotated fully clockwise or counter clockwise.

Outside Air and Exhaust Air Dampers:

Position the damper blades so that they will be closed once the actuator is installed. This will be the dampers spring return position. Note whether the damper shaft is rotated fully clockwise or counter clockwise.

SECTION 3 - HANDLING, STORAGE, & INSTALLATION (CONTINUED)

Actuator Installation

1. Remove the bearing plate from the damper frame and jackshaft.
2. Slide the damper actuator onto the open end of this shaft making sure that the proper spring return position on the face of the actuator matches the damper shafts rotation, if not then reinstall the actuator with it flipped over.
3. Reinstall the bearing plate to the damper frame and jackshaft.
4. Slide the damper actuator, mounting bracket into the actuator mounting grooves and fasten to the damper frame using self drilling screws.
5. Securely tighten the actuator shaft clamp to the dampers jackshaft. Make sure at this point the damper shaft is completely rotated to its proper position.
6. Manually operate the actuator to its fully actuated position using the crank arm provided with the actuator then release the spring to allow the damper to go back to its original position. This will verify the actuators spring rotation and stroke.
7. Set the damper actuators rotation selector switch to the proper rotation required to actuate the damper.

***** **NOTE** - This will always be opposite the spring return rotation.

TABLE 2 - DIRECT COUPLED ACTUATOR PARTS

VENDOR	PART #	BRACKET PART #
BELIMO	025-25737-001	086-00138-014
	025-25737-002	086-00138-014
JCI	025-39114-001	086-00138-013
	025-39114-002	086-00138-013
	025-39115-001	086-00138-016
	025-39115-002	086-00138-016
	025-39116-001	086-00138-014
	025-39116-002	086-00138-014
	025-39117-001	086-00138-014
	025-39117-002	086-00138-014

ITEM	DESCRIPTION	PART #
1	Damper	See Spec Sheet for P/N
2	Actuator	See Spec Sheet for P/N
3	Actuator Mounting Bracket	See Table
4	7.8" Length, 0.25" Hole, Black 6.6 Nylon	025-40605-001
5	Edge Clip # MCMS12-P-C	025-39067-002
6	Cable Tie 7.9: LG	025-39031-002

FIGURE 48 - INSTALLING THE DIRECT COUPLED ACTUATOR

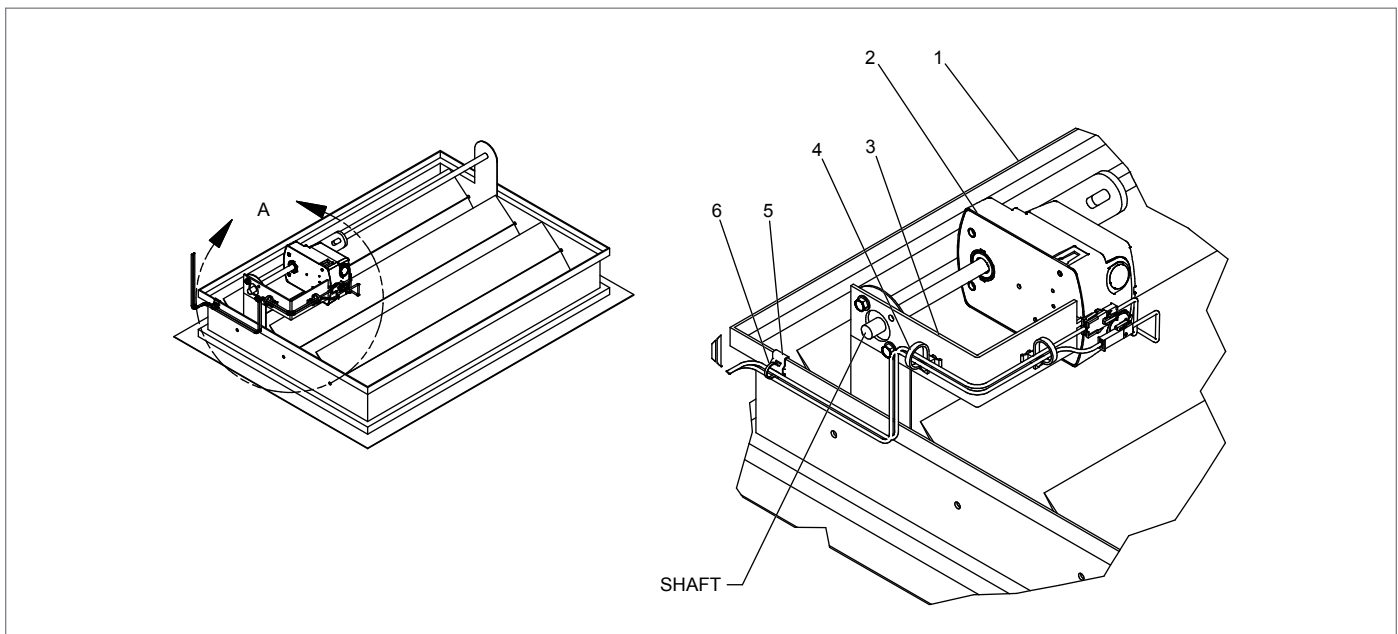

SECTION 3 - HANDLING, STORAGE, & INSTALLATION (CONTINUED)

Installing Multi-Zone (MZ) Dampers



NOTE - If the MZ segment has a shipping split, a rear discharge at the end of the AHU, and a MZ damper, the damper will be shipped loose.

1. Identify the gaskets and hardware needed for installation.



NOTE - Distortion will result in unreliable blade operation.

2. After the AHU top tier is assembled to the bottom tier and sealed, install the MZ damper assembly, which includes the hot (top) deck and cold (bottom) deck damper banks that are already connected at each blade as shown in Figure 49 (below).
3. Remove the 16 gauge shipping plate, which is located between the hot and cold decks from air entering side only.
4. Apply the neoprene gasket to the mounting flanges of the damper assembly.
5. Center the damper assembly over the discharge openings of the hot and cold decks.
6. Attach the damper assembly to the AHU's outer perimeter mounting flange, using the screws provided.
7. Remove the 16 gauge shipping plate from the air leaving side.
8. Install the screws through the mounting flanges between the hot and cold decks.

FIGURE 49 - INSTALLING MZ DAMPER

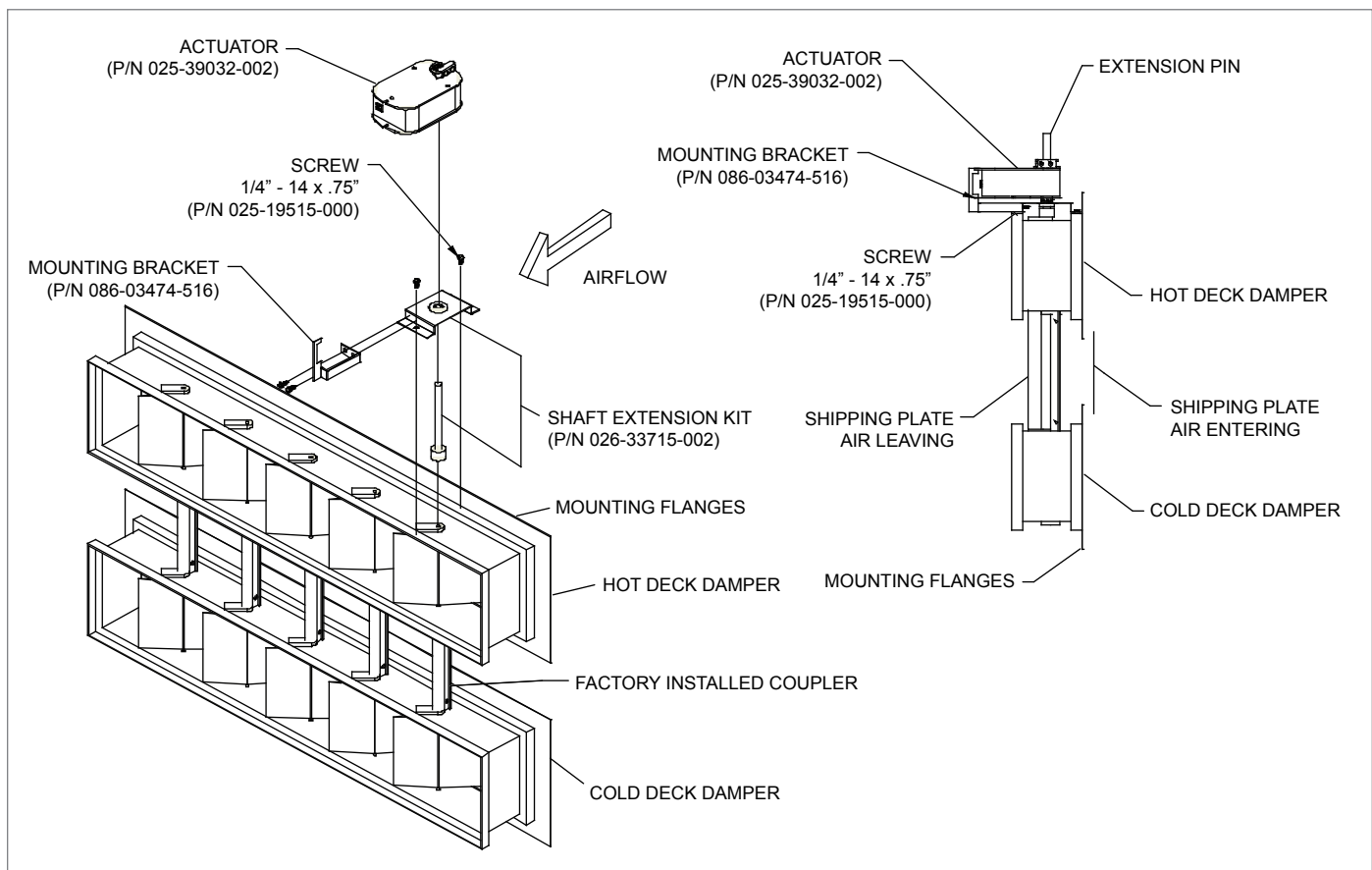

SECTION 3 - HANDLING, STORAGE, & INSTALLATION (CONTINUED)

Installing Field Supplied MZ Damper Actuators

When the actuators are field supplied for MZ dampers, use the following information to select the correct size actuator.

- Required torque is 7" lb/sq. ft. of damper area up to 2500 feet per minute (FPM).
- Damper blades are 6" wide and vary in height.
- Calculate the torque by the number and size of blades in each zone. There are hot deck blades directly connected to cold deck blades.
- Determine the number of blades per zone by the system cubic ft per minute (CFM), and static pressure requirements for each zone by the engineer's construction documents.
- Cut the blade linkage (flat rods) connecting all blades of each deck at the appropriate places to divide the decks into correct size zones. These rods are mounted externally on the assembly. Make sure to cut out a section of the flat connecting rod, which will prevent interference when the zones modulate in opposite directions.
- One damper shaft extension kit (P/N 026-33715-002), as shown in Figure 50 (right) is provided for each zone per the factory order form.
- The contractor should supply the actuators and mounting brackets. The part numbers are available upon request.
- On the rear mount (discharge through end of the AHU), always mount the actuators on the top of the upper deck.
- Do not allow the duct insulation to restrict the damper blades or external linkage.
- Direct coupled actuators are recommended.
- Make duct connections at the zone dividers without restricting the damper blade(s).

BACK DRAFT DAMPERS FOR DUAL FANS

The counterbalance is locked into place for shipping as shown in Figure 51 (right). Before startup, the counterbalance will have to be released. To do this, loosen the set screws and slide the counterbalance off the end of the shaft. Flip the counterbalance and slide it back on the shaft. Rotate the counterbalance above the damper as shown in Figure 52 (right), and then tighten the set screws. The counterbalance should be free to rotate.

FIGURE 50 - DAMPER SHAFT EXTENSION KIT (P/N 026-33715-002)

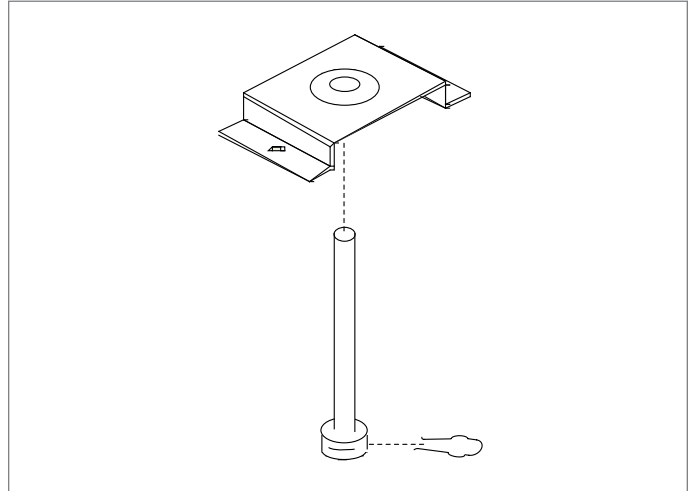

FIGURE 51 - COUNTERBALANCE LOCKED INTO PLACE FOR SHIPPING

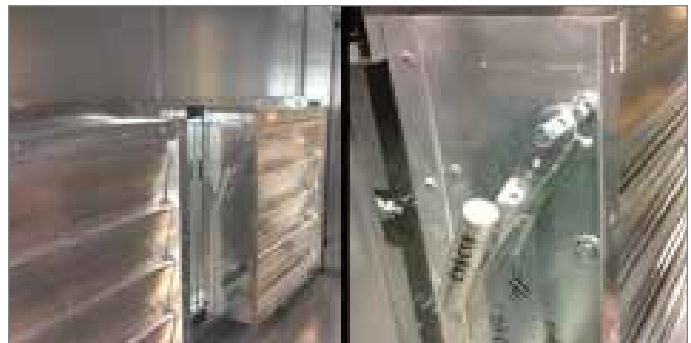

FIGURE 52 - COUNTERBALANCE UNLOCKED FOR START-UP



SECTION 3 - HANDLING, STORAGE, & INSTALLATION (CONTINUED)

FILLING INERTIA FAN BASE

Inertia fan bases are pre-engineered according to the fan and motor size. Use the following instructions to fill an inertia fan base with concrete.

- Calculate the amount of concrete by measuring the overall length and width of the fan base assembly cavities that have the corrugated metal bottoms. The standard depth of a cavity is 4".
- Fill each cavity to the top with wet concrete. Do not get concrete mix on the bolts and adjusting parts of the adjustable motor base, sheaves, belts, or on the floor under the edges of the isolated fan base.

STEAM HUMIDIFIER

If purchased, steam humidifiers are provided with factory mounted dispersion equipment inside the AHU. The steam injection or generating equipment, metering devices, and sundries are shipped loose with the AHU. Humidifier manufacturer's installation, operation and maintenance information is packaged with the humidifier. The installing contractor(s) is responsible for supplying all required steam supply and condensate piping, and wiring.

UVC EMITTER LAMPS

If purchased, the contractor is responsible for installing the UV lamps, and connecting a 120 volt power supply as shown in Figure 53 (right). Krueger's factory provides the following pre-wired parts.

- Internal wiring with a magnetic door safety switch.
- A lockable disconnect switch with a Press to Test pilot light.
- A latching circuit that has to be manually re-energized on the AHU's exterior after a door has been opened and closed.

Two Types of Lamps

Two different types of UV lamps are used in AHUs:

V-Mod Lamps - Install the two-pronged lamps into the slotted fixtures as shown in Figure 54 (right), then rotate the lamp 90°.

V-Max Grid Lamps - Fit the four-pronged lamp into the clamp mounted on the UV segment where a pigtail is installed. Insert the prongs into the pigtail plug.

FIGURE 53 - V-MAX GRID LAMPS

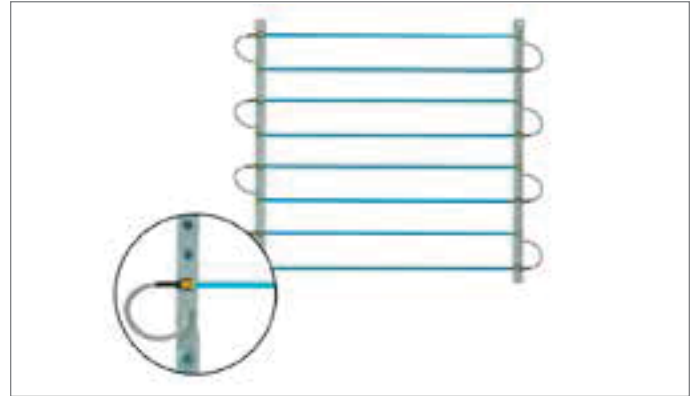
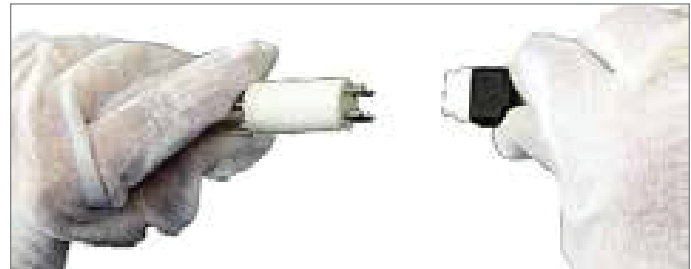

FIGURE 54 - INSTALLING V-MOD LAMP



FIGURE 55 - INSTALLING V-MAX GRID LAMPS



! **CAUTION** - Use clean cotton rags, clean jersey or latex gloves to handle the lamps. DO NOT touch UV lamps with bare hands or leather gloves because the oil will damage the lamps.

SECTION 3 - HANDLING, STORAGE, & INSTALLATION (CONTINUED)

FIGURE 56 - UV CONTROL PANEL WIRING (8 AMPS)

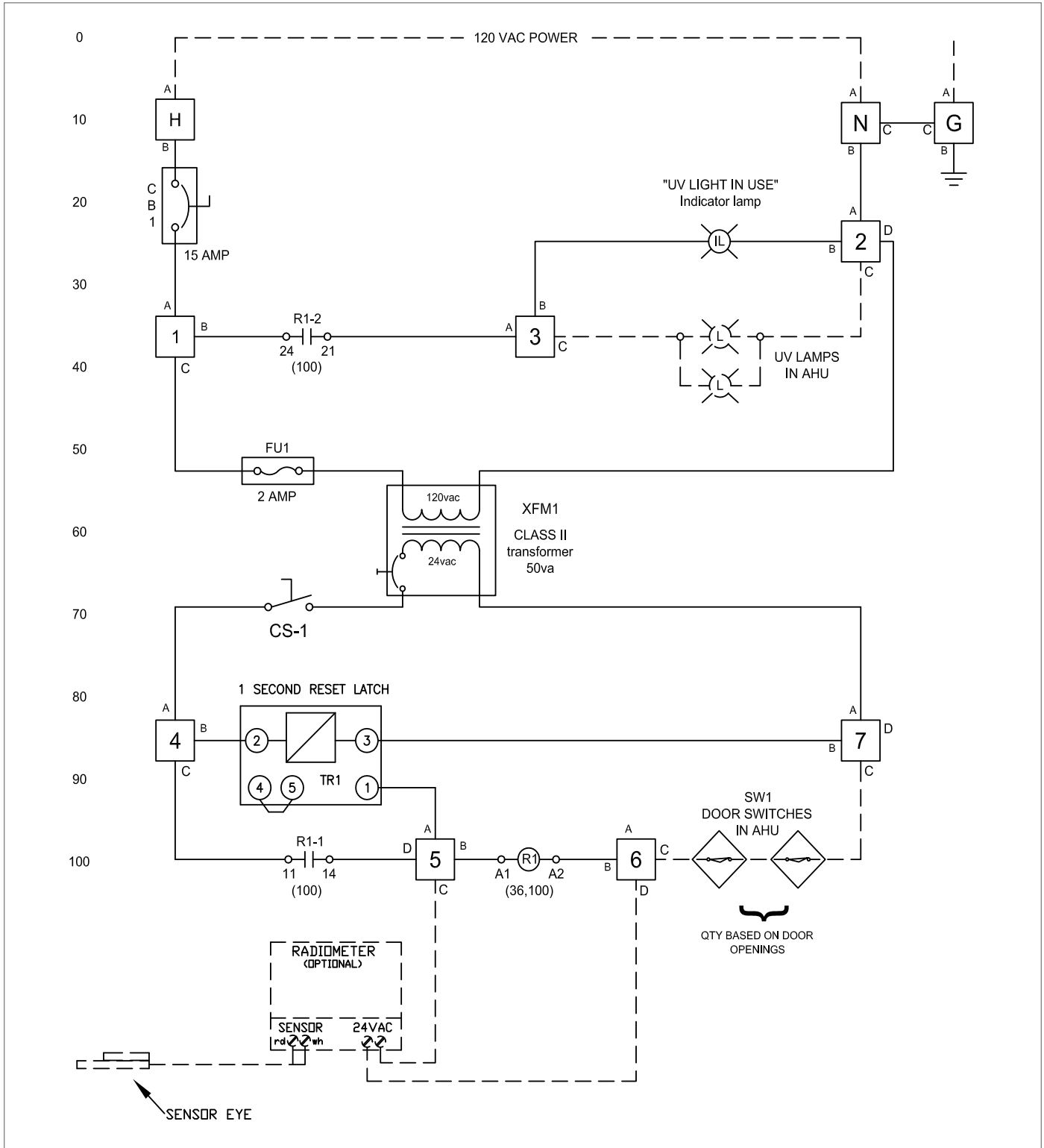

SECTION 3 - HANDLING, STORAGE, & INSTALLATION (CONTINUED)

FIGURE 57 - UV CONTROL PANEL WIRING (GREATER THAN 8 AMPS)

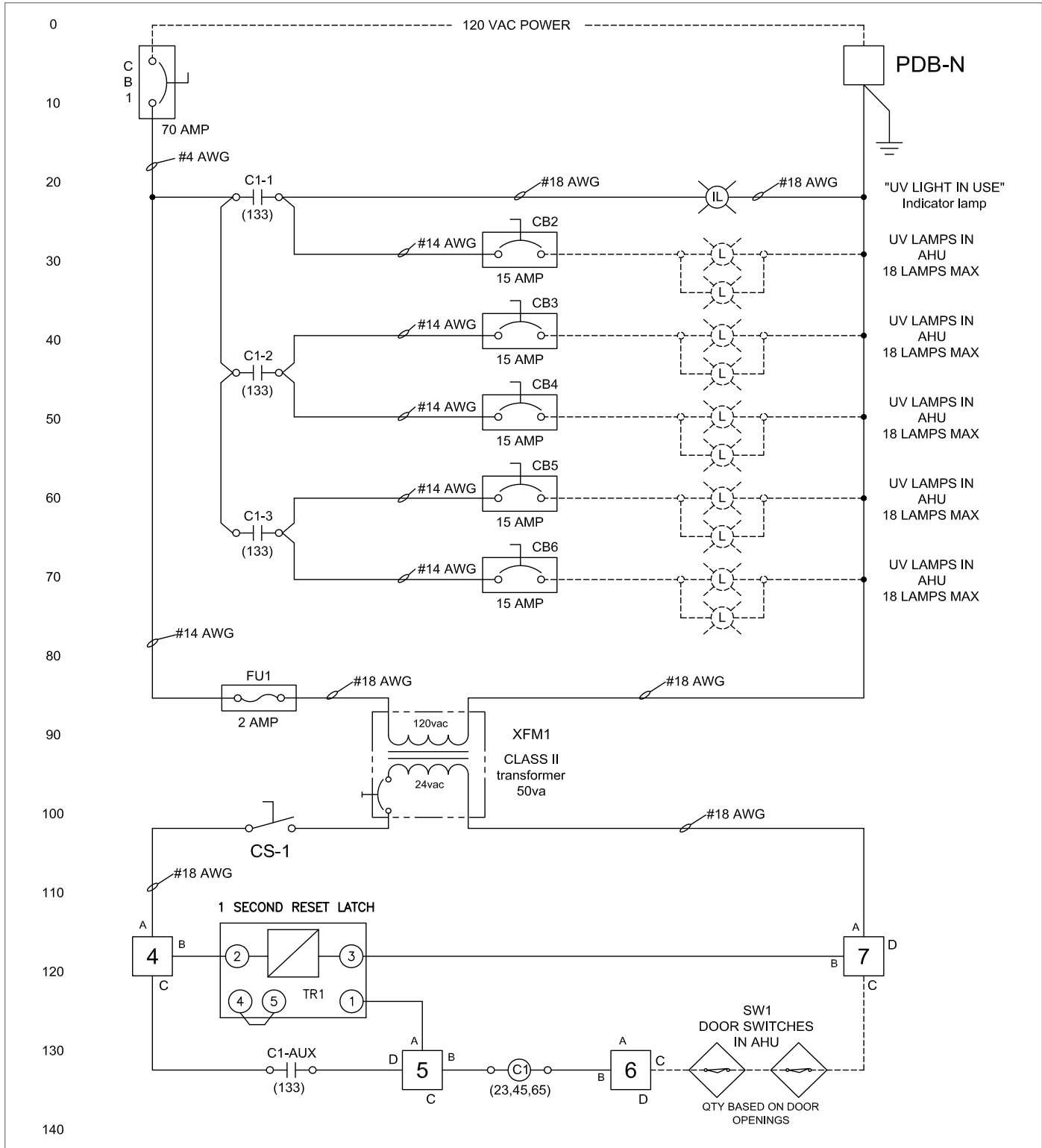

SECTION 3 - HANDLING, STORAGE, & INSTALLATION (CONTINUED)

FIGURE 58 - UV CONTROL PANEL WIRING (GREATER THAN 8 AMPS) (CONTINUED)

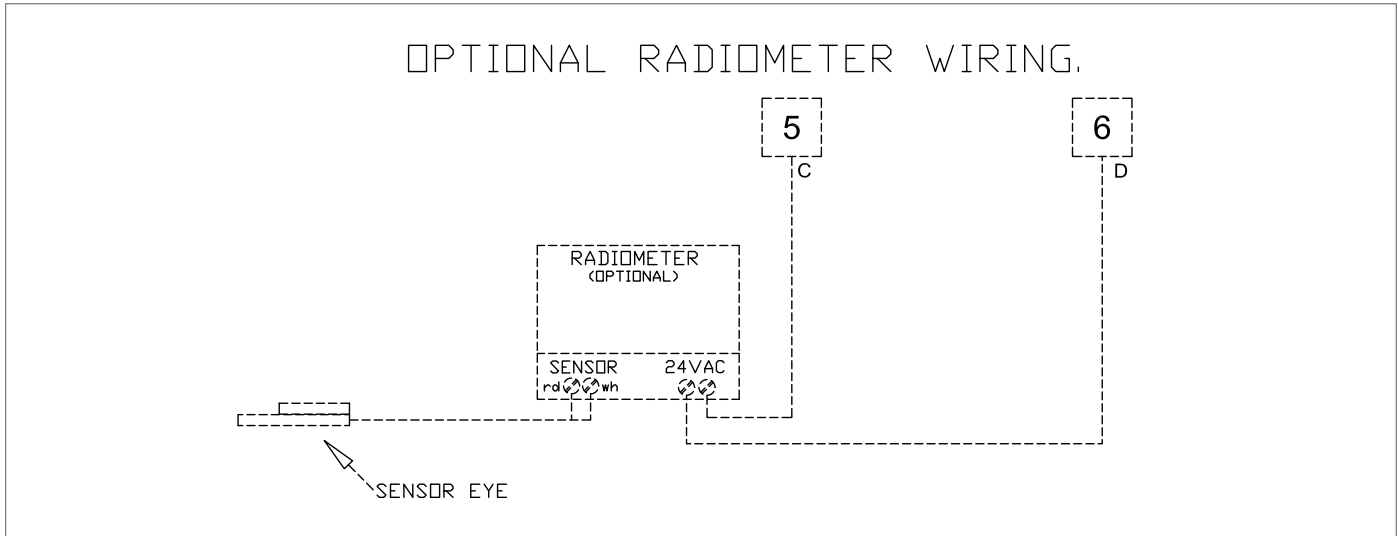

Sequence of Operation:

Disconnecting Means of UV lighting will be accomplished by “CB1” internal to the panel. “CB1” is cable of being locked out by panel latching mechanism.

“SW1” is a proximity switch with a magnet, which will close a set of normally open contracts. The magnet will engage the “SW1” contact whenever it is within 1/2” of the switch.

“TDR1” is one second (1 sec) time delay relay having normally open contacts. When power is initiated, its contacts will close for one second then re-open. To reset, power, power must be removed from “TDR1”

“C1” is a dpdt 24 vac control relay, used to seal-in its coil and provide interlocking means to the UV lights.

If all doors are closed, all the “SW1”s will allow “C1” to energize, as long as power is available.

By selecting “CS-1” to the “on” position, the 24vac control power circuit will be energized. As long as all doors with door switches (SW1) are closed and upon detection of power to the 1 second time-delay realy (TDR-1), the “TDR-1” normally open contracts will close for one second, energizing the contactor “C1” will remain energized. Should any one door having “SW1” mounted, were to open, “C1” will de-energize, deactivating the UV lamps. Closing all doors will not turn on UV lights. “CS-1” will be required, to be cycled “Off” then back “On” to allow the lights to come back on. If the power is removed from the UV control panel and re-energized (such as when power fluctuates off then back on), the UV lights will reactivate automatically. The “IL” “UV Light In Use” indicator lamp will allow the user to know if the lights have been energized.

SECTION 3 - HANDLING, STORAGE, & INSTALLATION (CONTINUED)

AIR MEASURING DEVICE CONNECTIONS

Inertia fan bases are pre-engineered according to the fan and motor size. Use the following instructions to fill an inertia fan base with concrete.

Air Measuring at the Fan Inlets

- COMETER is a probe attached to the fan bearing support on Comefri Forward Curve fans from size 7 x 7 up to 18 x 18. The probe is located on the outboard side of the housed fan assembly. The probe is piped to the negative (-) port of a factory mounted transducer on the fan wall. The positive (+) port is left open to the fan section. Wiring is not provided to the transducer unless factory packaged controls were selected.
- PIEZORING (PIEZOMETER) is a fitting or series of fittings in the inlet cone(s) of housed fans larger than 18 x 18 and all sizes of Plenum fans that are combined into a single connection piped to the negative (-) port of a factory mounted transducer on the fan wall. The positive (+) port is left open to the fan section. Wiring is not provided to the transducer.

 **NOTE** - The fan manufacturer does not recommend placement of the flow measuring probes inside the fan inlet cone in the path of airflow. These devices create disturbances and unpredictable performance losses.

Air Measuring at Unit Outside Air Inlets

AMS-60 used on AHUs usually measure outside air. This can be provided with one or two pairs of positive (+ or High) and negative (- or Low) pressure tube connections. Connect (+) & (-) respectively to the (+) & (-) ports of the transducer(s). Wiring and transducer are not provided.

FIGURE 59 - HIGH AND LOW CONNECTIONS FOR AN IN FAN AIR MONITORING SYSTEM

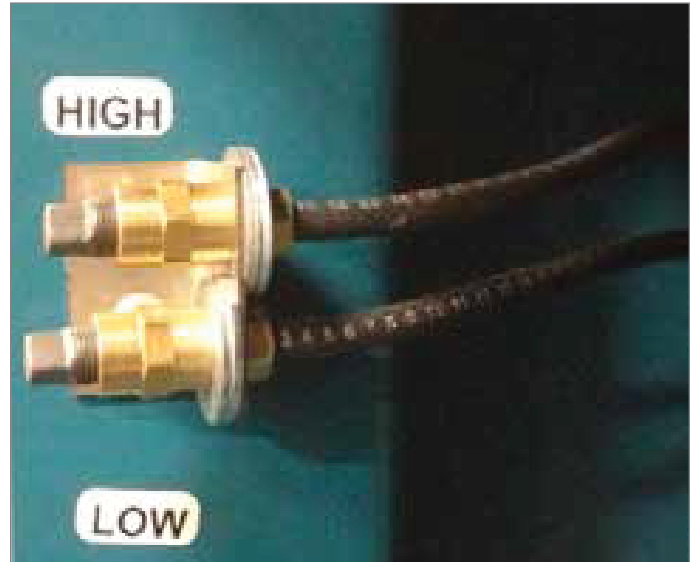

FIGURE 60 - PORT LOCATIONS FOR FAN MOUNTED AIR MONITORING SYSTEM



SECTION 3 - HANDLING, STORAGE, & INSTALLATION (CONTINUED)

CONDENSATE DRAIN ARRANGEMENT

The indirect fired gas heat exchanger has the potential to create highly acidic condensation, particularly during extended operation at low capacity or low firing rate conditions. To insure proper drainage, use the following instructions as shown in Figure 61 (right).

When constructing the condensate trap for the heat exchanger drainage system, make sure the trap is tall enough to handle the total static pressure (TSP) of the indoor blower at low fire times. For example, if a TSP is 6" at low fire, construct a trap that is 12" tall as shown in Table 3 (right).

1. Observe local codes for gravity condensate drainage requirements.
2. Install the AHU at an elevation that enables proper condensate drainage and trapping dimensions as shown in Figure 61 (right). Minimum trap dimensions **MUST** be accommodated.
3. The condensate drain line size must be the full line size of the heat exchanger drain connection.
4. Drain lines, fittings, and supports should conform to local codes, and be suitable for the application.
5. Condensate drain and trap discharge should be pitched away from the equipment at a slope of 1/4" per linear foot or as local code dictates.
6. For unconditioned space installations, local climate may dictate the need to heat trace and/or insulate the exposed drain lines and trap. Frozen drain lines and/or trap will cause build up of condensate inside the heat exchanger, resulting in leakage and damage to the AHU, and possibly to the building.
7. Provide unions in drain lines to allow removing the trap for periodic cleaning of drain lines and the trap. When the burner is operated at low capacity for extended periods, more condensate is generated, and with it deposits of solids in the condensate drainage system.
8. Provide the ability to prime the trap. During initial and seasonal start-up, trap inspection and priming is required. Condensate in the trap will evaporate during long periods of non-use.

TABLE 3 - TSP AND DRAIN TRAP

MODEL	DRAIN NPT	A	B	C
DF-15/25	1/2"	4"	2"	2"
DF-30/50	1/2"	8"	4"	4"
DF-60/75	1"	8"	4"	4"
DF-85/200	1"	12"	6"	6"
DF-225/400	1"	16"	8"	8"



CAUTION - Failure to follow these instructions may cause excessive condensation buildup, resulting in water damage to the facility and/or a cracked heat exchanger.

FIGURE 61 - GAS FURNACE CONDENSATE DRAIN TRAP

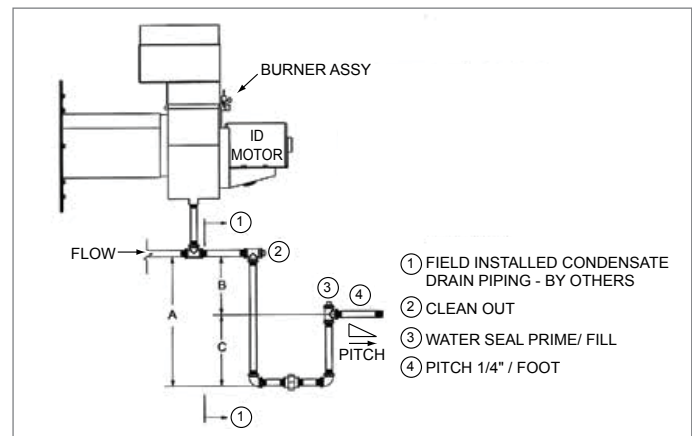

SECTION 3 - HANDLING, STORAGE, & INSTALLATION (CONTINUED)

FIELD PENETRATIONS FOR PIPING AND ELECTRICAL CONNECTIONS



NOTE - Make sure all penetrations and grommets are positively sealed on the cabinet exterior.



NOTE - For small sizes such as 1/2" iron pipe, 1/2" conduit or 5/8" O.D. copper and smaller; it is acceptable to use caulk instead of a grommet.



NOTE - Electrical conduits must be sealed internally to prevent airflow and moisture condensation.

Tools Required

- Drill motor.
- Pilot starter bit.
- Hole saws approximately 2-1/2", 3-1/4", and 4-1/2" diameter for holes.
- Power cords as required.

Material Required

- Neoprene grommet, 2-1/2", 3-1/4", 4-1/2" or 5-1/2" as required (see Figure 62 on the next page).
- Cold galvanized paint.
- Caulk, P/N 013-02966-011 gray for indoor units.
- Exacto knife.
- Clean up supplies.

Procedure

See Figure 62 on the next page.

1. Make sure any components; bulkheads or other obstructions are disconnected from panel inside and out.
2. Layout location and dimensions of hole opening to be cut. Do this on both sides of double wall panels.
3. Carefully cut correct hole size for the application in panel, insuring cuts on both sides line up and a smooth clean cut is made.
4. Paint raw edges of sheet metal with cold galvanized paint.
5. Select appropriate grommet for new panel hole and cut out appropriate hole diameter for penetration with an Exacto knife.
6. After paint dries, Install grommet into panel hole opening.
7. Apply sealant all around new hole opening behind lip of grommet, on both sides of panel.
8. Run pipe or conduit through grommet and make appropriate connections.
9. All modified panels must provide integrity equal to original equipment specifications.
10. Reconnect any components, bulkheads or other fixtures that were disconnected from panel in step # 1.
11. Thoroughly clean up inside and outside air unit.

SECTION 3 - HANDLING, STORAGE, & INSTALLATION (CONTINUED)

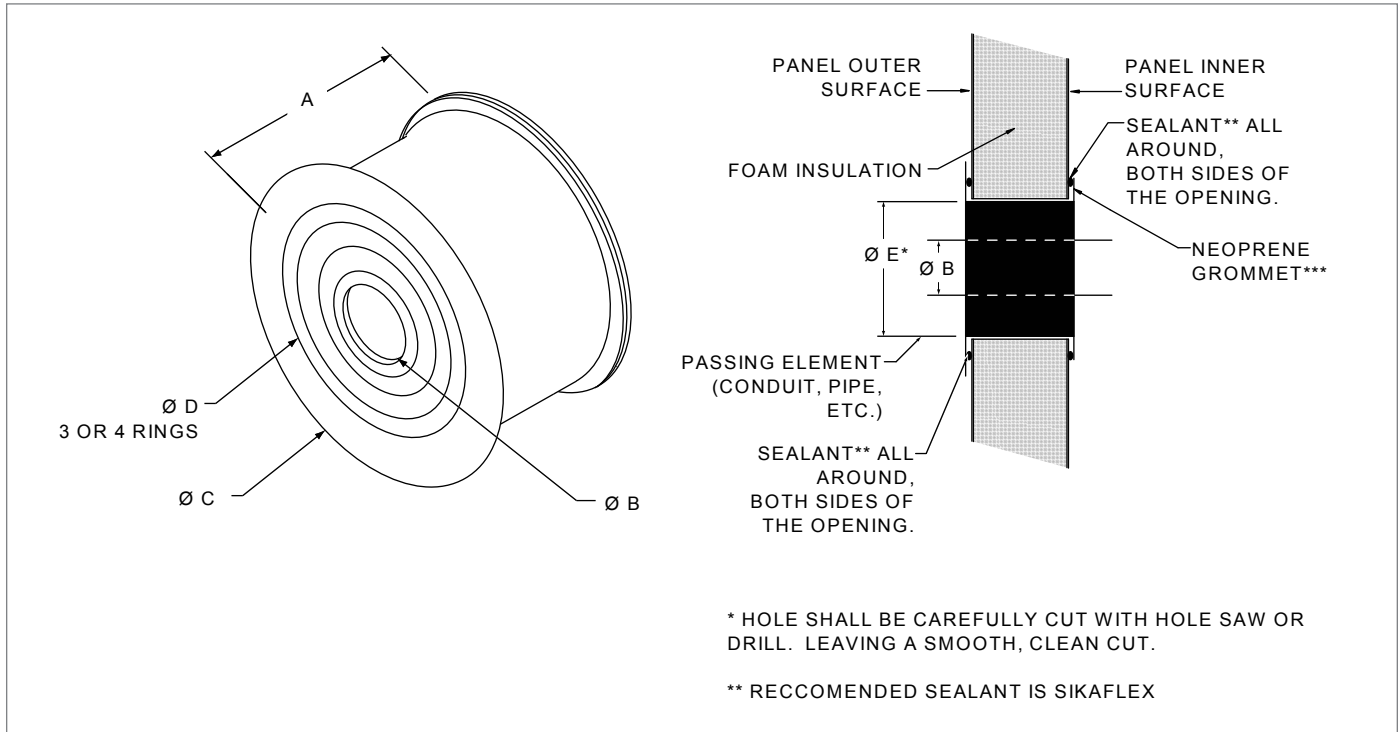
FIGURE 62 - PENETRATIONS AND GROMMET DETAILS

TABLE 4 - PENETRATIONS AND GROMMET DIMENSIONAL REFERENCES

IRON PIPE SIZE (NOMINAL)	COPPER PIPE SIZE (O.D.)	THIN WALL CONDUIT	USE GROMMET P/N	GROMMET DEPTH (A)	GROMMET HOLE DIAMETER (ØB)	GROMMET LIP DIAMETER (ØC)	MARKED GROMMET HOLE DIAMETER (CUT OUT) (ØD)	PANEL HOLE CUT DIAMETER (ØE)
3/4", 1"	7/8", 1-1/8"	3/4", 1"	028-11872-000	2.375"	0.500"	3.125"	0.749"	2.50"
1-1/4", 1-1/2"	1-3/8", 1-5/8"	1'1/4", 1-1/2"	028-11871-000	2.375"	1.000"	3.875"	1.249"	3.25"
1-1/4", 1-1/2"	1-3/8", 1-5/8"	1'1/4", 1-1/2"	028-11872-000	2.375"	0.500"	3.125"	1.249"	2.50"
1-1/4", 1-1/2"	1-3/8", 1-5/8"	1'1/4", 1-1/2"	028-11861-000	2.375"	1.000"	5.125"	1.251"	4.50"
2"	2-1/8"	2"	028-11871-000	2.375"	1.000"	3.875"	1.749"	3.25"
2"	2-1/8"	2"	028-11861-000	2.375"	1.000"	5.125"	1.751"	4.50"
2"	2-1/8"	2"	028-11872-000	2.375"	0.500"	3.125"	1.875"	2.50"
2-1/2"	2-5/8"	2-1/2"	028-11861-000	2.375"	1.000"	5.125"	2.251"	4.50"
2-1/2"	2-5/8"	2-1/2"	028-11871-000	2.375"	1.000"	3.875"	2.375"	3.25"
3"	3-1/8"	3"	028-11861-000	2.375"	1.000"	5.125"	2.875"	4.50"
4"	4-1/8"	4"	028-11881-000	2.251"	1.250"	6.125"	3.875"	5.50"

SECTION 3 - HANDLING, STORAGE, & INSTALLATION (CONTINUED)

GENERAL ELECTRICAL INFORMATION



NOTE - All field wiring must conform to the International Building Codes (IBC), National Electrical Code (NEC) and local codes.



NOTE - The AHU is ETL listed. Some components are UL labeled. Any changes in the field may affect its validity.

The current characteristics of phase, cycle and voltage are stamped on the nameplate of each component. Use the following instructions to set up the electrical connections.

- Install electrical conduit connections, which are made to exposed boxes, to the bottom of the box.
- Seal the penetrations through the panels.
- Externally and internally seal the electrical conduits that penetrate the AHU exterior (walls or floors) so that the unconditioned air will not be drawn into the AHU through and around the conduit. Unconditioned air will result in condensation that will fail components prematurely.
- Check all accessible electrical connections, which contain several strands of wire, for tightness prior to start-up. The wires are tightened at the time of assembly, but check, and retighten them, if necessary. The dangers of a poor connection are overheating and component failure.



CAUTION - DO NOT PENETRATE any main or auxiliary drain pan.



WARNING - DO NOT PENETRATE wireways in any manner. The sheet metal channels, which run along the top panel, contain electrical wires and connections. Electrical shock and/or damage to the AHU may result.

Electrical drawings are provided in the information packet on the inside of the AHU access door. Major optional components will have specific electrical and installation information inside the control panels or will be attached. Refer to Section 4 - Wiring Diagrams in the AHU Operation and Maintenance Manual for more information on the electrical drawings.

POWER CONNECTIONS

Single Point Power

When ordered, the single point power connection provides the installer with a main disconnect switch as shown in Figure 63 (below). The line side of this switch (top) is where the installer is to connect his main power wires. The devices included in the single point power option are:

- Supply, Return, and Exhaust Fans
- Energy Recovery Wheel
- Gas and Electric Heat
- Ultra-violet Lights

Special quoted devices not included in this option may be purchased with the AHU, and will require separate, additional power wiring by the installer. When this option is NOT purchased, the installer is responsible for wiring to each electrical component.

FIGURE 63 - SINGLE POINT POWER CONNECTION



SECTION 3 - HANDLING, STORAGE, & INSTALLATION (CONTINUED)

Motors for Supply, Return, and Exhaust Fans

A motor connection diagram may be found on the inside of the motor terminal box or on a tag attached to the motor. Be sure to make a flexible conduit connection at the motor to permit fan belt adjustment and movement of the spring isolated fan assembly. Refer to the motor data nameplate for all motor specifications as shown in Figures 64 and 65 (right).

To access the motor electrical box when the motor is installed in the configuration as shown in Figure 66 (right), use the following instructions.

1. Remove the motor bolts that secure the motor to the motor base.
2. Remove the belts.
3. Rotate the motor or move it back far enough to access the electrical box.
4. Connect the motor wiring per the motor wiring diagram.
5. Replace the motor electrical box cover.
6. Rotate or move the motor back into place and secure it to the base with the bolts.
7. Reinstall the belts to the proper alignment and tension according to the drive kit label found on the fan assembly.



NOTE - In some applications, only three bolts need to be removed. The fourth bolt, located on the opposite side of the electrical box, does not have to be removed but will need to be loosened. After it is loose, rotate the motor to access the electrical box to make the connections.

FIGURE 64 - TYPICAL MOTOR DATA /NAME PLATE



FIGURE 65 - ANOTHER TYPICAL MOTOR DATA / NAME PLATE

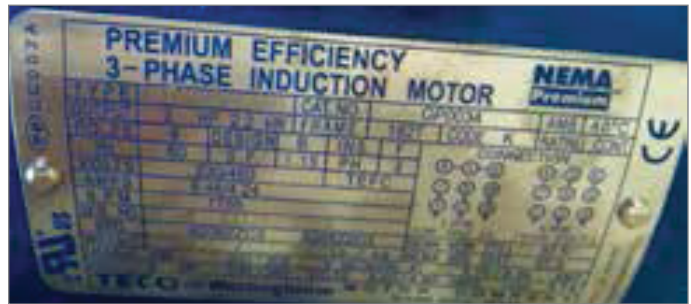
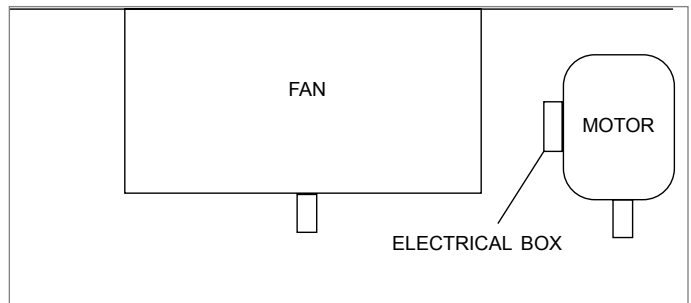

FIGURE 66 - ACCESS ELECTRICAL BOX



SECTION 3 - HANDLING, STORAGE, & INSTALLATION (CONTINUED)

WIRING THE ENERGY RECOVERY WHEEL

It is the installer's responsibility to wire the energy recovery wheel, if single point power was not purchased. Using the attached plug and/or pigtail is optional. Krueger does not provide pre-wired mating cables.

For wheels that are 52" diameter and smaller, the motor comes with a cord. Wheels that are 54" in diameter and greater, the motor does not come with a cord. Single phase motors have a 3-pin standard AMP connector on the cord. Three phase and VFD models have a 4-pin standard AMP connector on the cord.

WIRING THE GAS HEAT DEVICE

It is the installer's responsibility to wire this device, if the single point power connection was not purchased.

Panel locations and sizes vary based upon the AHU's size and burner configurations. Burner voltage is selected to match the primary AHU voltage. Modulation control voltage 2-10 VDC is standard.

Electrical penetrations can come through the floor or side wall panels. Drill and properly seal any penetrations to keep out moisture. Refer to the Service Manual for more information.

Make power connections per the wiring diagrams provided on the inside of the burner control panel. Refer to the Operation and Maintenance Manual for more information.

FIGURE 67 - TYPICAL POWER WIRING OF ENERGY RECOVERY WHEEL



FIGURE 68 - MAIN POWER AND CONTROL PANEL WITH COVER OPEN

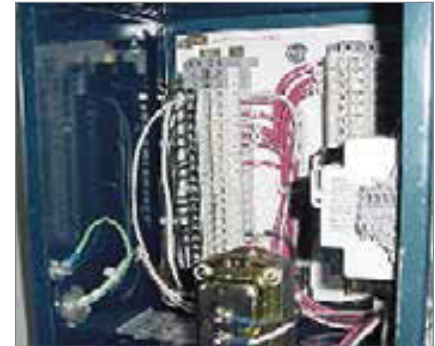
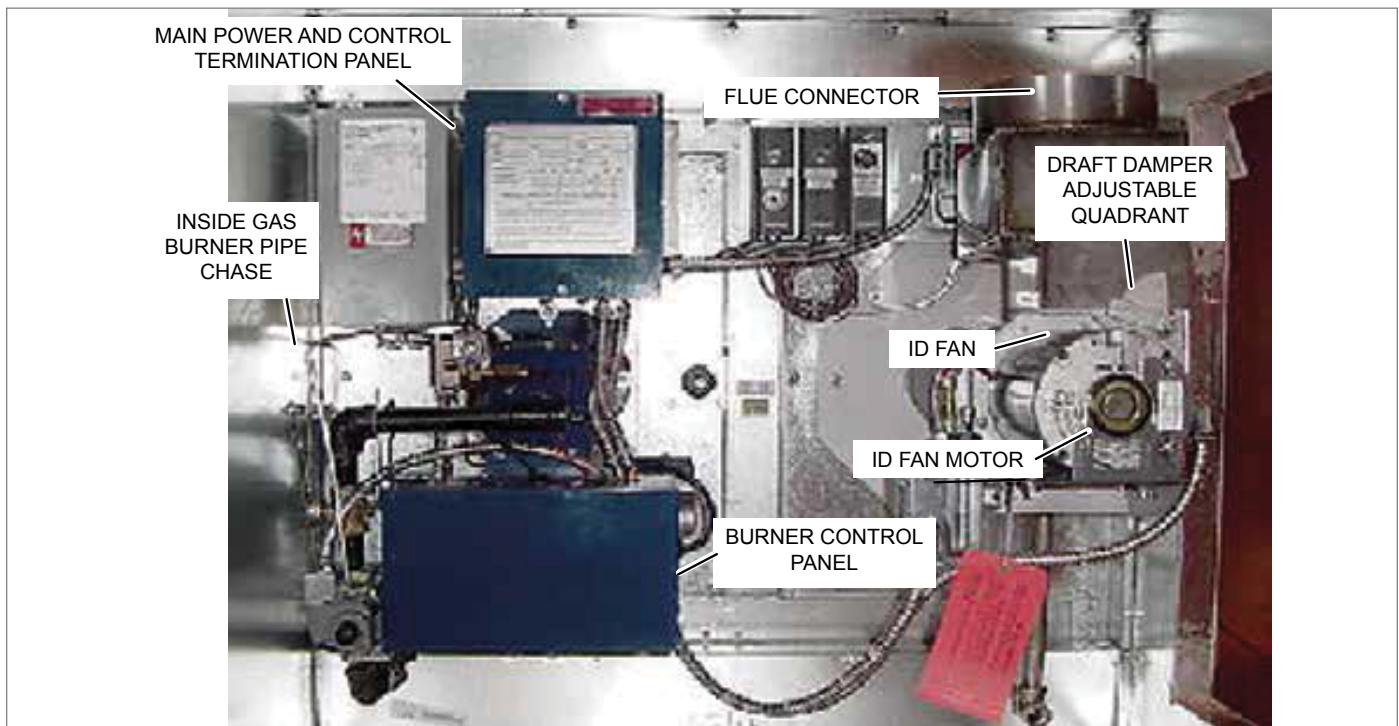

FIGURE 69 - GAS BURNER COMPONENT LOCATIONS



SECTION 3 - HANDLING, STORAGE, & INSTALLATION (CONTINUED)

WIRING THE ELECTRIC HEAT DEVICE

It's the installer's responsibility to wire this device, if the single point power was not purchased.

Power Options

The available power options are listed below:

- 460V-3PH
- 208/230V-3PH
- 380V-3PH
- 575V-3PH

Disconnect Switch Options

The available disconnect switch options are fused and non-fused.

Knockouts are provided on the top and bottom of the enclosure for field penetrations. Drill the foam panel to utilize these knockout locations. Seal the penetrations to prevent airflow or leakage. Refer to the Service Manual for more information.

Use the following instructions to connect the disconnect switch:

1. Hook up the power, as shown in Figures 70 and 71 (right). Terminals (shown) are for a 2-stage 24 VAC control interface, and may require a 120VAC control interface, based upon the options selected. Refer to the wiring diagram on the inside cover of the electric heat control panel for more information.
2. Seal the electrical conduits that penetrate the AHU's exterior (walls or floors) externally and internally so that the unconditioned air will not be drawn into the AHU through and around the conduit. The unconditioned air will result in condensation that will fail components prematurely.
3. Check all accessible electrical connections for tightness prior to the actual startup. Many connections contain several strands of wire, and while they were tightened at the time of assembly, they should be checked and retightened if needed. The dangers from a poor connection are overheating and component failure.



CAUTION - DO NOT PENETRATE any main or auxiliary drain pan.

FIGURE 70 - TYPICAL ELECTRICAL HEAT CONTROL PANEL INTERIOR WIRING AND COMPONENTS

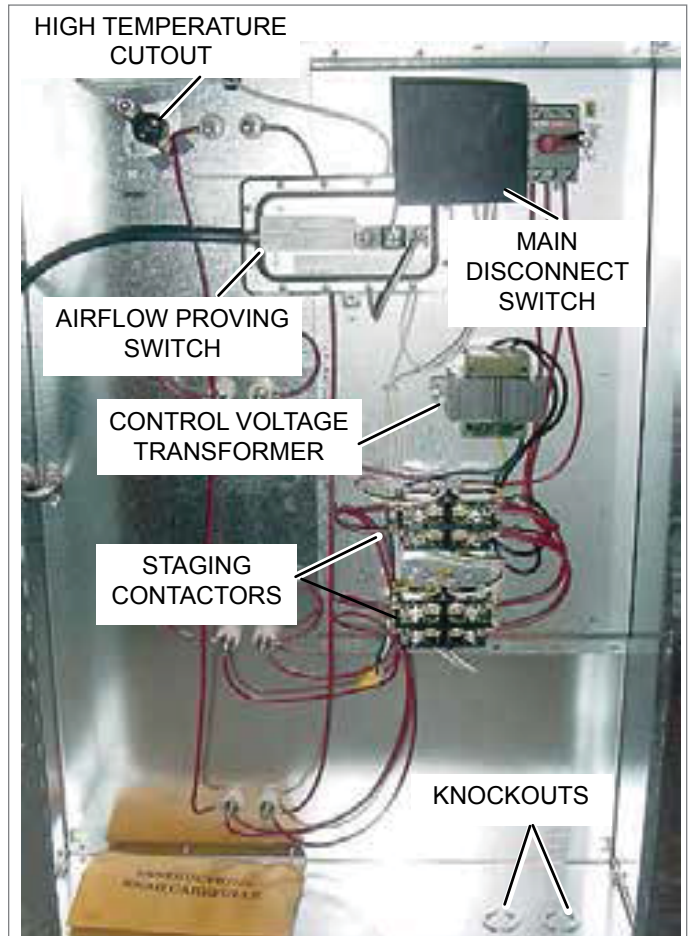
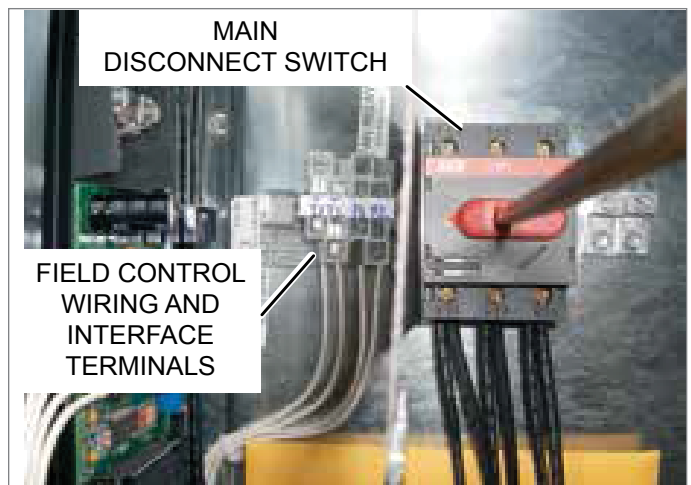

FIGURE 71 - TYPICAL FIELD AND POWER CONNECTIONS



SECTION 3 - HANDLING, STORAGE, & INSTALLATION (CONTINUED)

Control Options

The available control options are:

- **Staging** - Has no controller, but contactors are energized by providing control power to each contactor from the external BMS source.
- **Step Controller** - A mechanical/electrical device that receives a 0 to 10 VDC or 4 to 20 mA signal, and step-on heat stages.
- **Vernier Silicone Controlled Rectifier (SCR)**
 - » Completely electronically controlled by varying signal and varying output between stages.
 - » Increases power to a stage by modulation until another stage is needed.
 - » Energizes another stage and modulates power until another stage is needed. 0 to 10 VDC or 4 to 20 mA.
 - » Less expensive than a full SCR. This system utilizes a step controller and one SCR that modulates and resets for each stage.
- **Full SCR** - Completely electronically controlled by varying signal and varying output of a controller like a VFD for electric heat with 0 to 10 VDC or 4 to 20 mA. The controller modulates a separate SCR for each stage.

Installing Electrical Heat Option



WARNING - Rotating parts and electrical shock hazards exist. Lockout and tagout the fan motor(s) and heat power disconnects before servicing, using the latest procedure. Failure to follow proper safety precautions may result in serious injury or death.

Application Information

Follow the procedure given in these instructions to find the minimum air velocity for safe operation. The minimum velocity must be provided at all points over the heater face area.



CAUTION - Failure to meet this requirement may result in serious damage or nuisance thermal cutoff tripping.

The maximum air inlet temperature for open coil heaters is 100°F, and for finned tubular heaters is 80°F.

Sufficient working space must be provided per paragraph 110-26 of the NEC.

This electric heater is not designed for or intended to be used for temporary heat prior to system startup/balancing.

Mechanical Installation

All heaters will contain an adjustable airflow switch in the heater control panel. This switch will be preset to close at a differential pressure of approximately 0.3" water column (WC). In all cases, the switch will be connected to a pressure probe positioned in the airstream as shown in Figure 72 (below). This probe has an arrow stamped on it that is viewable from inside of the control panel. When the heater is located upstream of the fan, this arrow will point away from the fan. When the heater is located on the downstream side of the fan, the arrow will point away from the fan or with the airflow.

If it is incorrectly installed, remove the two screws holding the pressure probe in place and rotate 180° and reinstall. The airflow switch pressure port that is not connected to this pressure probe will be run to the exterior of the AHU to source a reference differential pressure.

In some situations it may be necessary to adjust this airflow switch setting to allow for proper operation as shown in Figure 73 on the next page. Take precautions to make sure that the airflow switch does not indicate false airflow.

Visually inspect the heater elements, prior to using the heater. If physical damage is evident, use a megohm test to validate the heater elements are safe use. If a minimum value of 10 megohms is not achieved, then any damaged elements or ceramic insulators must be replaced, prior to operation.

FIGURE 72 - PRESSURE PROBE DIRECTION

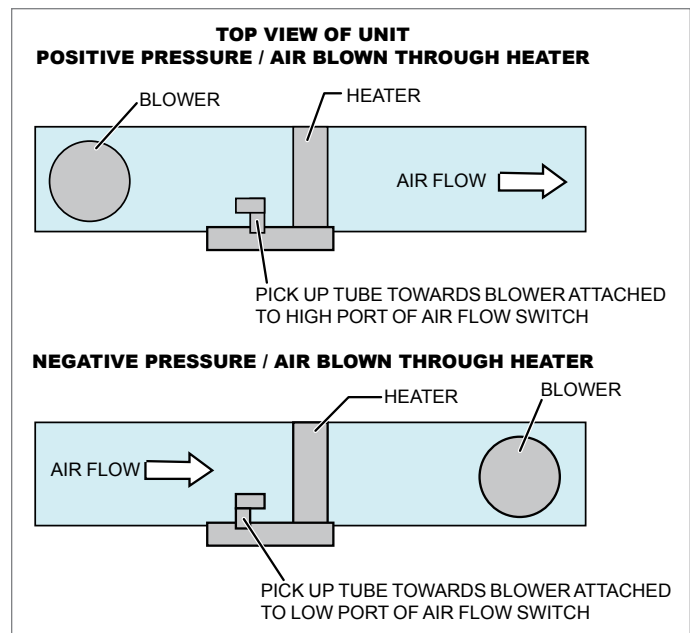

SECTION 3 - HANDLING, STORAGE, & INSTALLATION (CONTINUED)

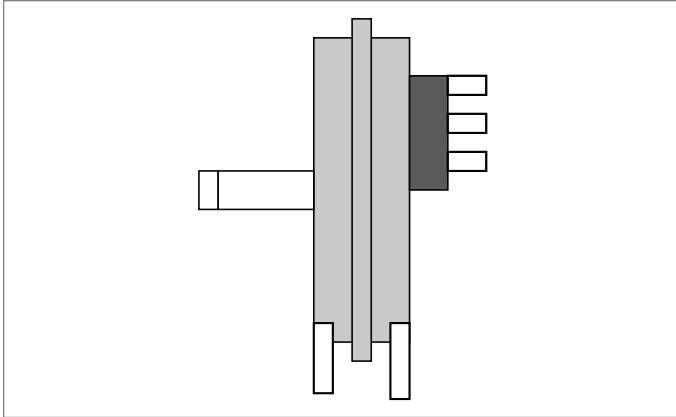
FIGURE 73 - AIRFLOW SWITCH CONNECTIONS

Electrical Installation

1. Follow the wiring diagram on the inside of the terminal box.
2. Make supply connections with copper wiring rated for 75°C minimum.
3. If supply connections are for 250 volts or greater, all wiring must be insulated for 600 volts.
4. When making line connections to heater element terminals for finned tubular heaters only, apply a 1/4" wrench to the flat section of the terminal immediately below threads. Otherwise, damage to the terminal may result.
5. Size supply conductors for heaters rated less than 50 kW at 125% of rated load. On heaters rated 50 kW and greater, size the supply conductors at 100% of rated load, if indicated on the wiring diagram. The line current for a single or three phase load is calculated as follows:

$$\text{Single Phase Line Current} = (\text{kW} \times 1000) / \text{Voltage}$$

$$\text{Three-Phase Line Current} = (\text{kW} \times 1000) / (\text{Voltage} \times 1.73)$$

6. Table 5 (below) shows the maximum current for 75°C copper wire with no more than three conductors in a raceway, which is based on the NEC - Table 310-16. The ampereages are 125% and 100% wire sizes. If there are more than three conductors in a raceway, de-rate these ampereages per Table 5 (below).

When connecting heaters with more than one stage, wire stage No. 1 so that it is the first stage on, and the last stage off.

7. Wire the heater so that it cannot operate unless air is flowing over it, which can be accomplished by using a built-in airflow switch and a remote interlock. See the wiring diagram located inside of the electric heater control panel for the method used with the heater and provide appropriate interlock wiring as illustrated.
8. If not supplied as part of the heater, install a line disconnect switch or main circuit breaker in accordance with the NEC. Depending upon the heater's location and accessibility, a built-in disconnect switch may meet this requirement.
9. Check all electrical connections in the heater, including both field and factory made connections, for tightness before operating the heater. After a short period of operation, check all connections again for tightness.
10. If the heater is wired to a heating/cooling thermostat, use a thermostat with isolating circuits to prevent possible interconnection of Class 2 outputs.
11. If the heating elements are divided into several sections with resistance wire between two or more sections, calculate the maximum kW per sq. ft as follows:

$$\text{Heater Nameplate kW} = \text{No. of Heated Sections} \times \text{Area of Heated Section}$$

TABLE 5 - MAXIMUM CURRENT

AMPS		WIRE SIZE AWG/MCM	AMPS		WIRE SIZE AWG/MCM	AMPS		WIRE SIZE AWG/MCM
125%	100%		125%	100%		125%	100%	
12	-	14	80	100	3	184	230	4/0
16	-	12	92	115	2	204	255	250
24	-	10	104	130	1	228	285	300
40	-	8	120	150	0	248	310	350
52	65	6	140	175	2/0	268	335	400
68	85	4	160	200	3/0	304	380	500

SECTION 3 - HANDLING, STORAGE, & INSTALLATION (CONTINUED)

ELECTRIC HUMIDIFIER

It's the installer's responsibility to wire this device because this device is not included in the single point power option.

Figure 74 (below) represents a typical electric humidifier panel layout. The supply power knockout is located in the bottom of the electrical panel as shown in Figure 75 (right). All conduits beginning or ending on the inside of the pressurized or conditioned areas (i.e. AHU) must have the conduit openings sealed to prevent air from passing through it.

All AHU penetrations must be sealed to prevent air and water leakage. Refer to the Penetrations and Grommet Details section in the Service Manual.

Field provided disconnects must provide circuit protection according to the humidifier nameplate. All field wiring to the humidifier must be in accordance with NEC and local codes.

FIGURE 74 - LAYOUT OF TYPICAL HUMIDIFIER PANEL



HUMIDIFIER

Control wiring diagrams are located in the humidifier manufacturer's operator's manual, which can be found inside the control panel or it is attached. Factory package control drawings may not include humidifier points as shown in Figure 76 (below).

If the humidifier operator's manual cannot be located inside the humidifier, call Krueger Technical Support to get a copy of the electronic version.

FIGURE 75 - SUPPLY POWER KNOCKOUTS

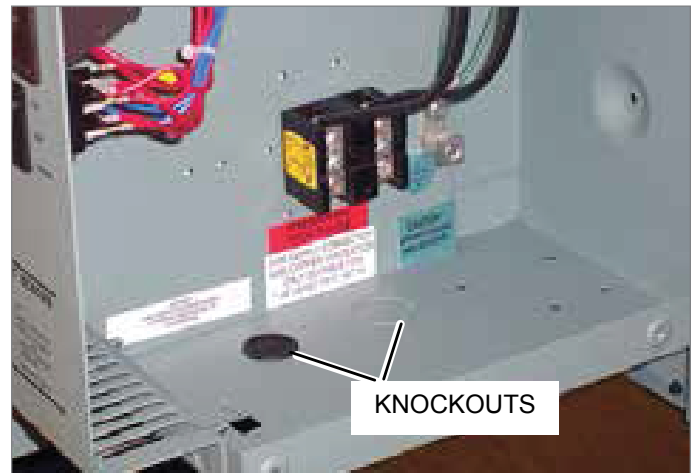

FIGURE 76 - HUMIDIFIER POINTS



SECTION 3 - HANDLING, STORAGE, & INSTALLATION (CONTINUED)

LIGHTS FOR AHUS

If the AHU is equipped with lights, the following parts are shipped loose for a tiered unit, as shown in Figure 77 (below).

- Conduit (P/N 025-39024-001)
- SJO Cord (P/N 025-35746-01)

FIGURE 77 - AHU WITH LIGHTS TIER TRANSITION DRAWING

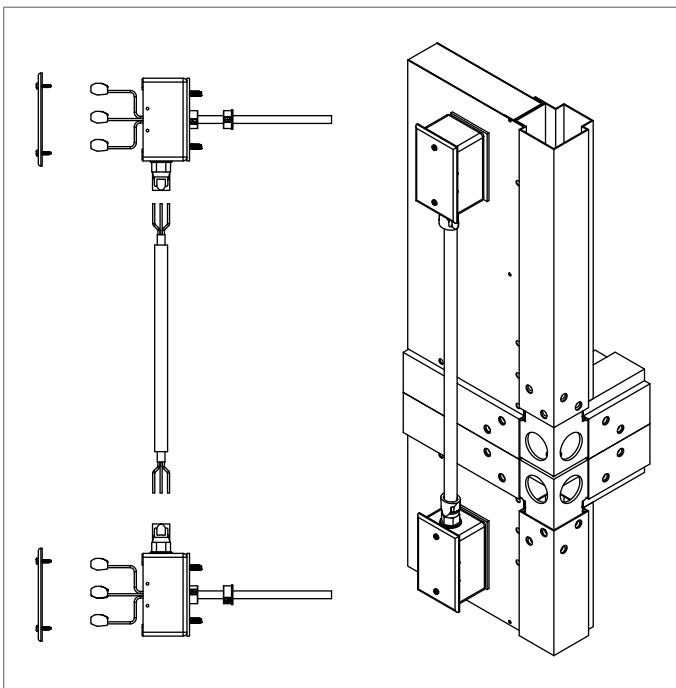

PIPING CONNECTIONS

When extended piping is present inside the AHU, the field provided and installed insulation is required.

Penetrations through panels must be sealed. Refer to the Service Manual for more information.

Where piping is insulated, insulation should not be installed until after the flashing is completed.

COIL PIPING



CAUTION - Do not test, clean and flush piping through this equipment.

Isolate this equipment from pressure testing of water, steam gas and air piping.

1. Consult the job specifications and submittal drawings for specific piping requirements, coil connection sizes and location. The AHU should be level to assure proper venting and draining of coils. The piping arrangements must provide for a balanced flow in multiple coil installations as shown in Figure 78 (below).
2. Support all connecting piping independently of the coils. Provide swing joints or flexible fittings in all piping connections, particularly adjacent to heating coils to absorb expansion and contraction strains because rigid piping connections can cause coil damage.
3. The coil supply and the return pipe connections are labeled. When attaching the piping to the coil header, make the connection only tight enough to prevent leaks. Excessive tightening may cause damage to the header.

Hold a backup wrench firmly on the coil connection so that when tightening the connecting piping, the torque is not transmitted to the coil header, which could damage the coil connection.

Application Notes - All connections are male piping threaded except DX coils, which are soldered. Drain and vent taps on water coils are pipe thread, and shipped with plugs installed. These taps are installed approximately 2" back from the end of the threaded connections. Install the pipe for balanced flow and to assure even airflow.

FIGURE 78 - FACTORY COIL CONNECTIONS

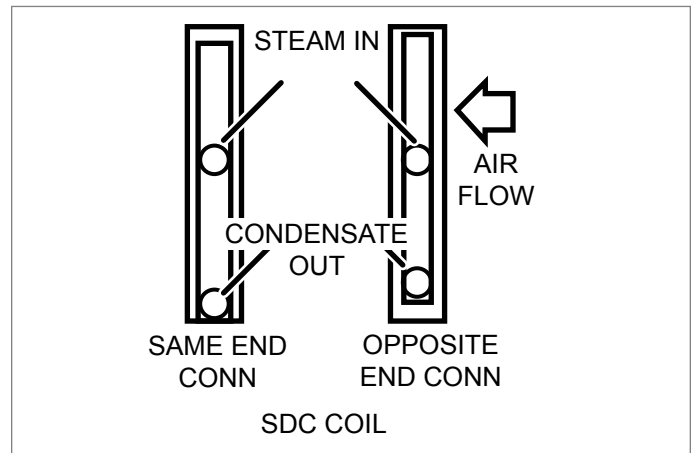

SECTION 3 - HANDLING, STORAGE, & INSTALLATION (CONTINUED)

Staggered Coils

Staggered coils in the AHUs will have connections brought to the AHU exterior for liquid or steam coils as shown in Figure 79 (below). DX coils are not included.

The external connections are a threaded pipe or grooved pipe for the contractor to make his connections when the media is liquid, or a threaded pipe when the media is steam.

It's the installing contractor's responsibility to insulate the piping extensions inside the AHU.

FIGURE 79 - STAGGERED COIL, ANGLED WALL

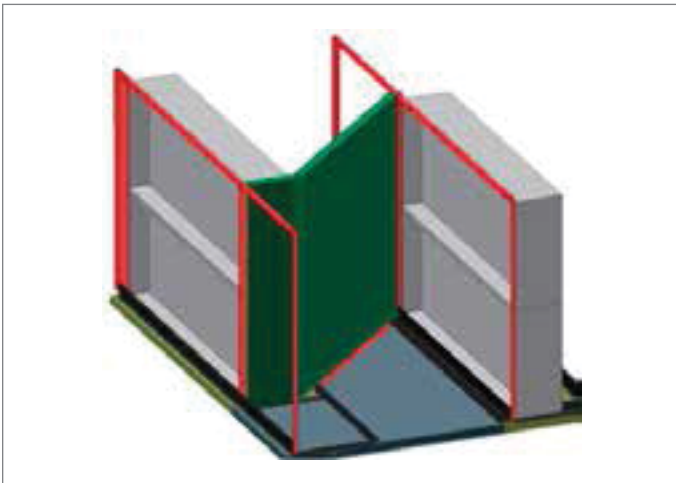
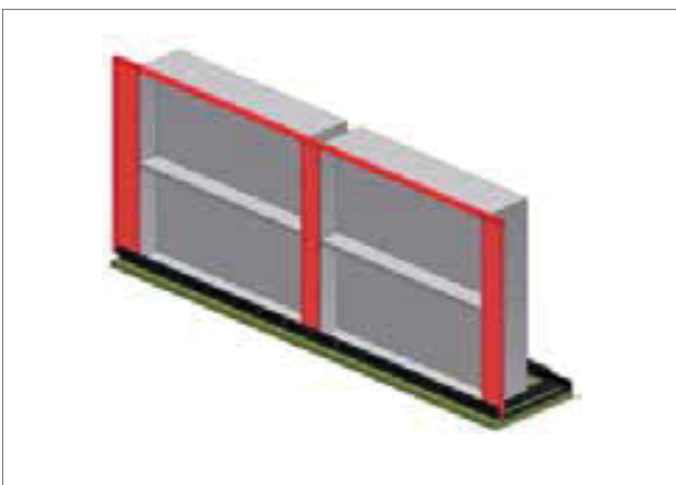

FIGURE 80 - SPLIT COIL, OPPOSITE SIDE CONNECTIONS



Hot and Chilled Water Coils

1. Connect the water supply to the header connection on the leaving air side of the coil to achieve the counter flow of water and air. The return pipe will be connected to the remaining coil connection.
2. Install an air vent in place of the top pipe plug on the return header. To provide for drainage, install a drain line and shutoff valve in the supply near the coil, or in place of the plug in the supply connection as shown in Figures 81 and 82 on the next page and Figure 83 on page 46.

Water Coil Performance



CAUTION - Full steam pressure of water flow must be supplied at all times - modulating valves must not be used. A modulating steam valve or preheat coil can actually cause the coil to retain condensate due to a reduced pressure in the coil thus exposing condensate in the tubes to freezing conditions. With modulating steam below 5 psig (valve closure) the steam may not be fully distributed in all of the tubes in the coil, causing the outer tube to cool abnormally. This will create thermal stress that can lead to possible "outer tube failure".

The temperature rise of the air (hot water coil) or temperature fall of the air (chilled water coil) leaving the coil is dependent on the:

- Airflow across the coil,
- Gallons of water flow through the coil, and
- Entering water temperature into the coil.

Consult the job submittal form for more information.

SECTION 3 - HANDLING, STORAGE, & INSTALLATION (CONTINUED)

FIGURE 81 - CHILLED WATER COIL CONNECTIONS EXAMPLE - (NOT FOR CONSTRUCTION)

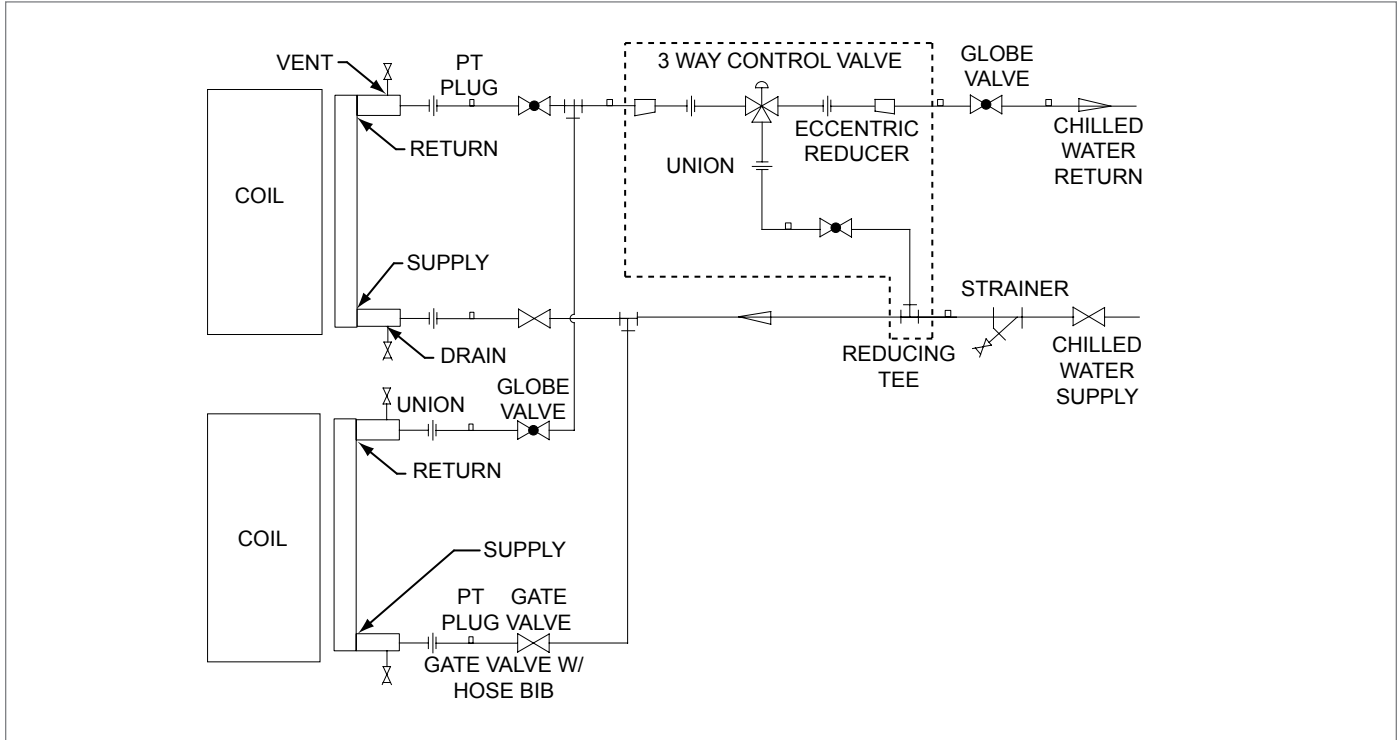
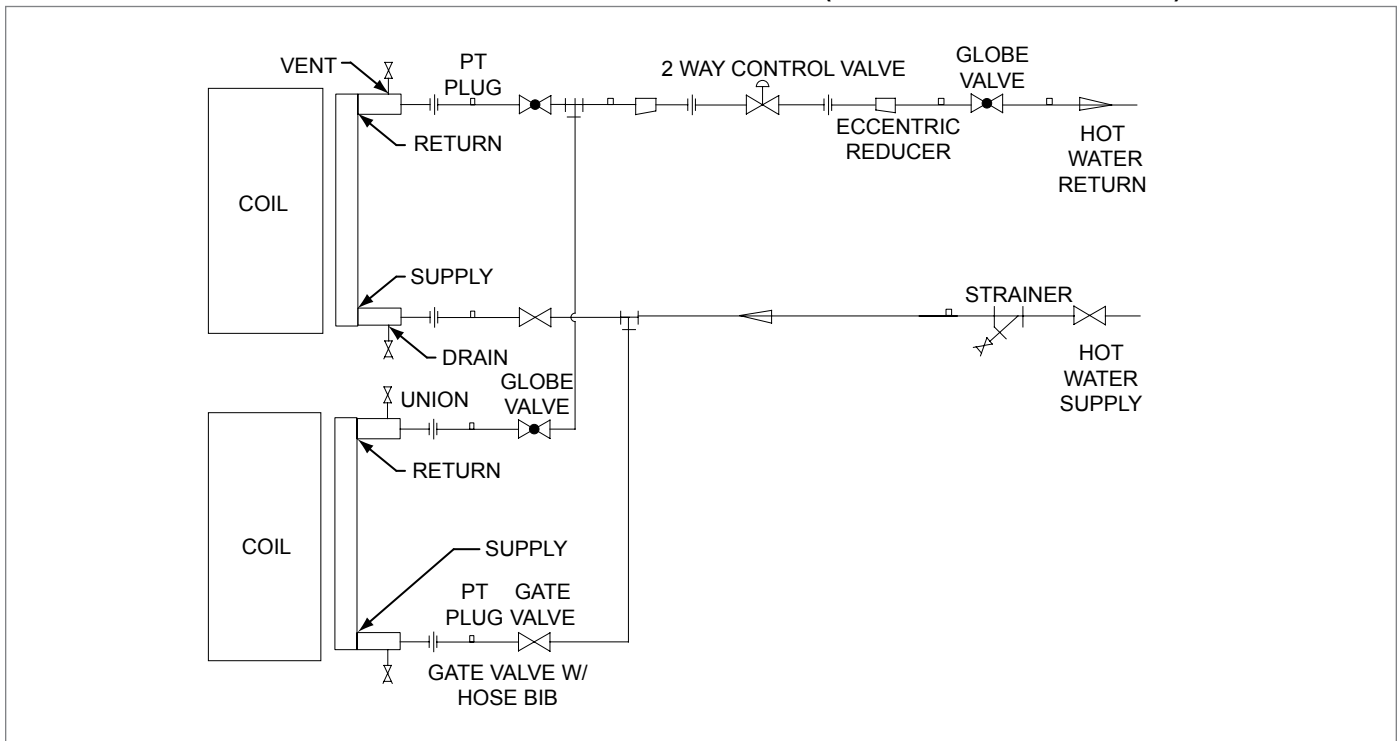
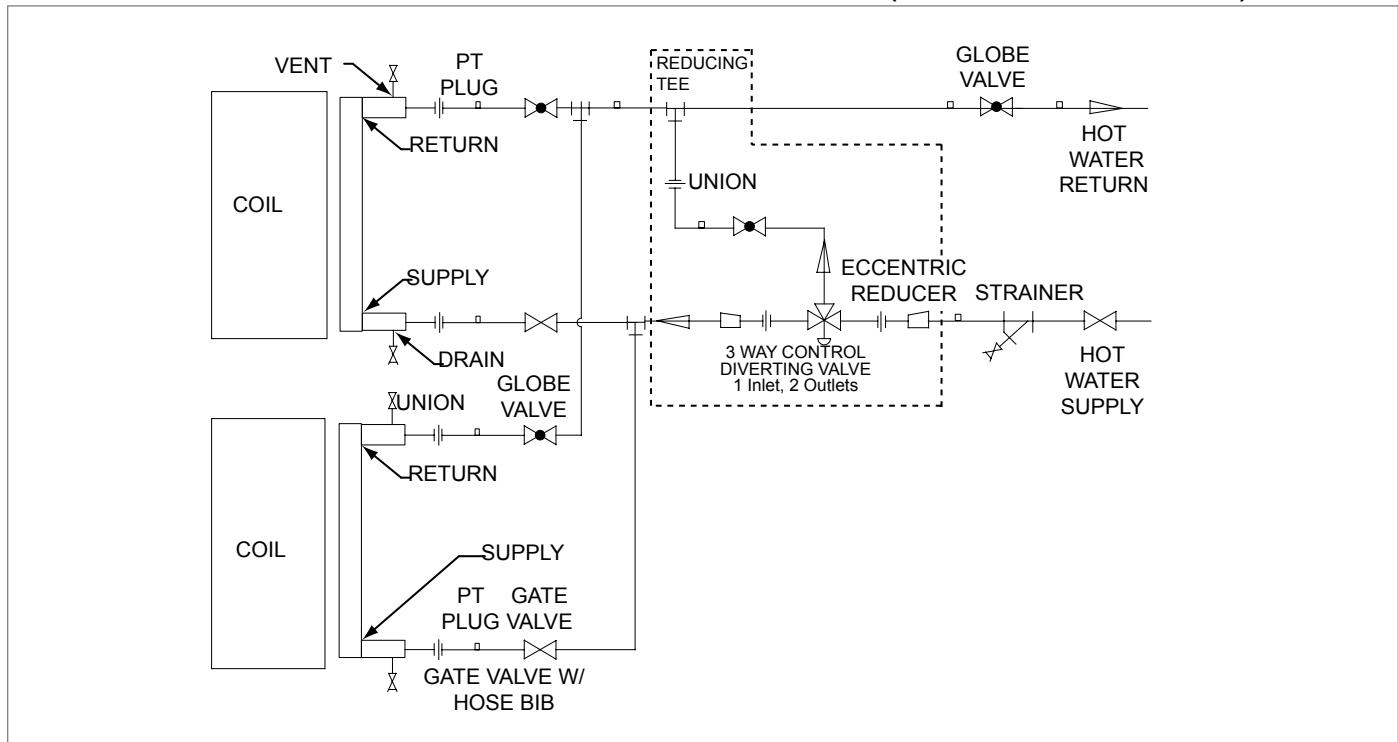

FIGURE 82 - HOT WATER PIPING WITH 2-WAY VALVE EXAMPLE (NOT FOR CONSTRUCTION)



SECTION 3 - HANDLING, STORAGE, & INSTALLATION (CONTINUED)

FIGURE 83 - HOT WATER PIPING WITH DIVERTING VALVE EXAMPLE (NOT FOR CONSTRUCTION)



WATER TREATMENT

Any copper tube coils may be attacked by acid condensate. Treat the coils with boiling water and CO₂ to remove the condensate, and to assure longer tube life.

Freeze Protection

Chilled water, hot water, and steam coils can be damaged during freezing weather. Take the following precautionary measures to prevent freezing:

- Positive coil freeze protection must be used in installations where any part of the water coil is subjected to temperatures of 32°F or lower, which may be accomplished by using a suitable antifreeze solution. If the coil is not in use, it is recommended to drain the coil completely, and blow dry the inside of the tubes with compressed air.
- After draining, flush the coils with an anti-freeze solution such as 50% glycol and 50% water, which will protect from the coil from freezing to approximately -35°F at sea level. Refer to ASHRAE and AHRI guidelines for more information.
- During winter when shutdowns such as power failure, night and weekend shutdowns may occur, install the controls so the return air dampers go to the fully open position, and all fresh air dampers go to the fully closed position. A source of auxiliary heat must be maintained inside the AHU cabinet.
- Other protection can include electromechanical switches and constantly flowing water; however, Krueger will not be responsible for any coils damaged by freezing.

SECTION 3 - HANDLING, STORAGE, & INSTALLATION (CONTINUED)

Steam Coils

The operation of steam coils is dependent on airflow quantity and temperature as shown in Figure 84 on the next page. Consult the job submittal form for the information specific to this AHU.

Steam Distributing Coils

Use the following instructions to clean the steam distributing coils:

- Do not bush or reduce the coil return pipe size.
- Use a full size return pipe to the bottom of a dirt pocket. The supply pipe may be reduced at the coil connection, if necessary.

Steam Control

Continuous steam supply ensures long coil life and minimizes potential trapping, venting and freezing problems. A rapid cycling of the modulating steam supply or a frequent on-off steam supply control results in repeated thermal and piping stresses which will shorten the coil life. Modulating steam control valves must not be oversized, and must be carefully selected. A substantial variation in the supply pressure will require installing a pressure-reducing valve ahead of the automatic control valve.

Light load operation with a modulated steam supply can be improved by the installation of a vacuum breaker check valve. An open relief line to the atmosphere from the return line near the coil is desirable, except on vacuum systems.

With a modulated steam supply, it is not practical to lift the condensate to an overhead return. Locate the coil well above the return, or provide condensate unit, or a boiler return trap below the coil.

Individual control valves are required on each coil installed in series with respect to airflow. When a modulating steam valve supplies two or more coils in parallel, with respect to airflow, the piping must be designed to provide uniform steam distribution to each coil.

Steam Traps

Use the following information to select the correct steam trap.

- Float and Thermostatic (F and T) traps are recommended for all low or medium pressure applications.
- Use bucket traps only for a non-modulated steam supply.
- Size the steam traps in accordance with the manufacturer's recommendations (usually several times the steady state steam flow).
- Use the actual operating conditions (coil pressure vs. return pressure) to select a trap.
- It is preferable to provide an individual trap for each coil, but a single trap may be used for coils operating in parallel with respect to the airflow. Coils in series with respect to airflow must be supplied with individual traps.
- Locate the trap at least 12" below the coil return connection, and lower it when freeze protection is required. Do not attempt to lift condensate modulated steam supply.

SECTION 3 - HANDLING, STORAGE, & INSTALLATION (CONTINUED)

FIGURE 84 - STEAM COIL PIPING ARRANGEMENTS

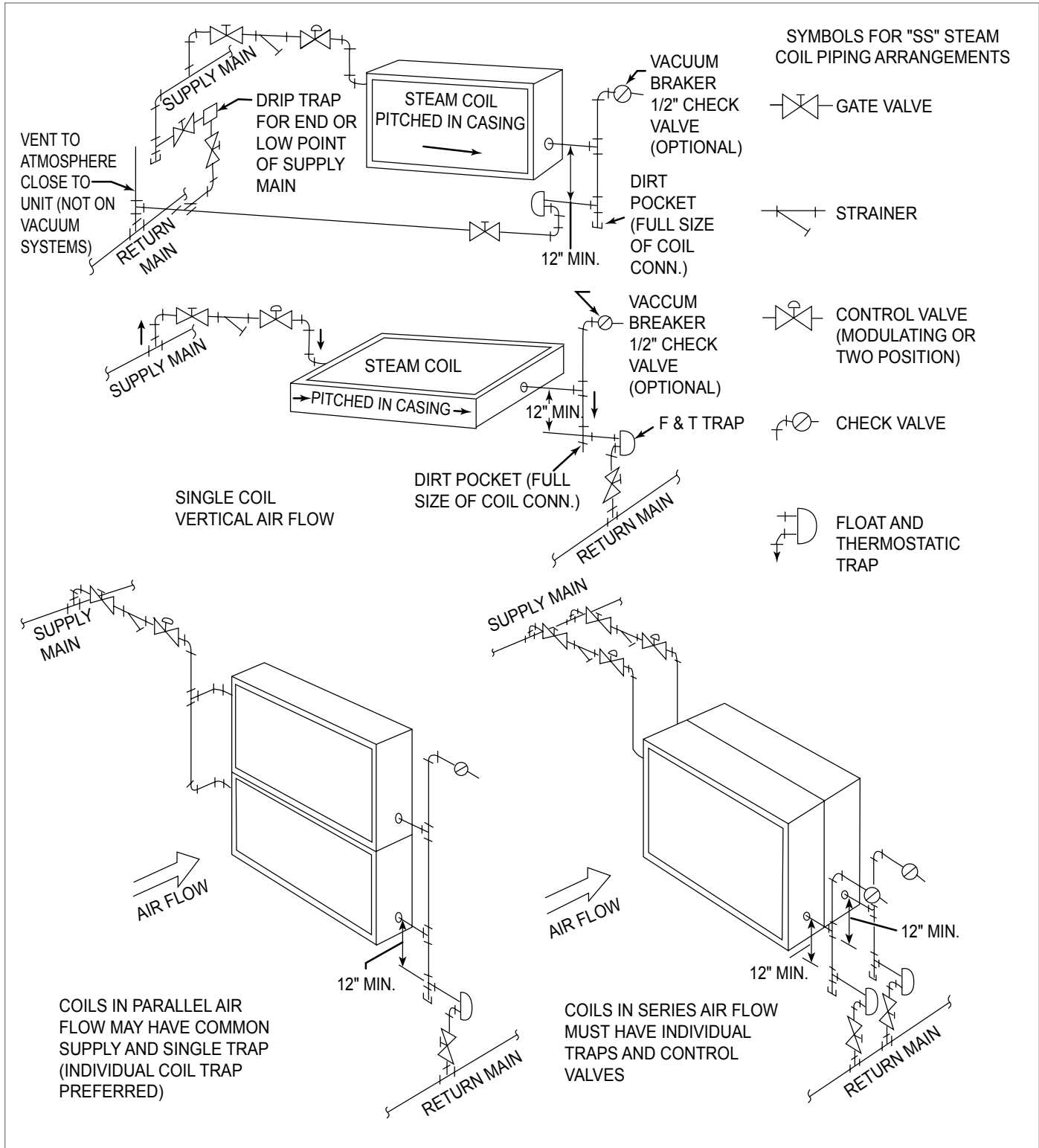

SECTION 3 - HANDLING, STORAGE, & INSTALLATION (CONTINUED)

VERTICAL TUBE INTEGRAL FACE AND BYPASS (VIFB) AND INTEGRAL FACE AND BYPASS (IFB)



CAUTION - The VIFB warranty will be voided if the return piping on the lower header (inlet and return on two-row header) does not include flexible connector(s), and if the lower header(s) bolts are not removed prior to use.

The VIFB lower header must be free to float as shown in Figure 85 on the next page. After the coil is piped, remove the yellow bolts to allow the header to float. Always back up the coil connections when installing the fittings.

Below 35°F, the IFB, as shown in Figure 85 on the next page, or the VIFB, as shown in Figure 86 on the next page, operates with full steam pressure or full water flow at all times, which prevents freeze-up and temperature stratification.

Shipping Bolts (VIFB Only)

Return steam condensate headers or hot water supply and return headers are securely bolted to lower mounting brackets to prevent damage to the header and tubes during shipment and piping of the coils. Remove the bolts before applying steam or hot water, but after making all of the piping connections, as shown in Figure 86 on the next page.

Piping Suggestions

Read the following information before installing the piping.

- Support the steam and hot water field piping separately after the flexible connector to isolate the piping strains and additional expansion from the coils.
- Insulate the internal steam manifolds and piping.
- Size the steam traps three times the calculated condensate loading at the coil design conditions, based on the pressure differential across the trap, not the boiler pressure. Traps should be of types that pass condensate and air at saturated steam temperature. Inverted bucket traps should incorporate thermostatic air vents.
- Make the return connection full size as required, and reduce only at the trap. Do not use the reducing bushing on the coil return connection.

Flexible Connectors (VIFB Only)

Return steam condensate headers, hot water supply, and return headers must be free to float. A flexible connector MUST be installed as close as possible to the coil, and parallel to the headers to accommodate a minimum of 1/2" expansion movement of the headers.



CAUTION - Failure to install flexible connectors will restrict expansion of the headers, which can result in bowing of the tubes, bending of the fins, interfering with damper operation, or eventually breaking the tubes.

Refer to the Service Manual for more information.



NOTE - Anti-stratification baffles are standard on all IFB and VIFB coils mounted in the AHUs.

The outside air and return air must be thoroughly mixed before passing over the coil. When freezing air enters only part of the coil, it creates a greater hazard than when the airflow entering the coil is a uniform temperature.

Coils used in series with respect to the airflow must have individual controls with ample space between the coils for sensing devices, when required. Coils with two or more rows are more sensitive to freezing than single row coils.

The low limit element must cross the face and bypass areas and be parallel to the headers.

Refer to the IFB/VIFB Operator's Manual (provided) for additional piping details. The Krueger factory does NOT pipe the connections to the AHU exterior.

SECTION 3 - HANDLING, STORAGE, & INSTALLATION (CONTINUED)

FIGURE 85 - IFB COIL (HORIZONTAL TUBES AVAILABLE WITH STEAM AND HOT WATER)



FIGURE 86 - VIFB COIL (FACE-MOUNTED ACTUATOR SHOWN)



SECTION 3 - HANDLING, STORAGE, & INSTALLATION (CONTINUED)

FIGURE 87 - HOT WATER PIPING FOR IFB

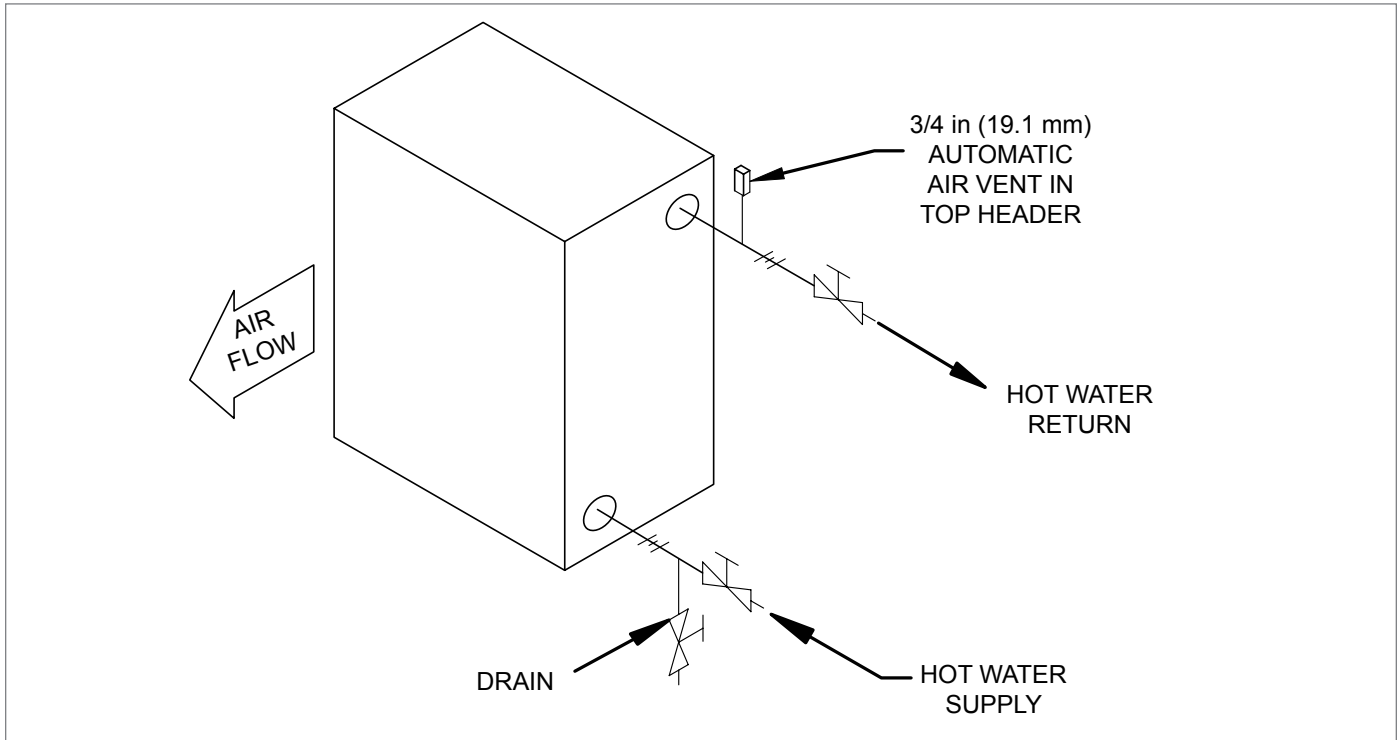
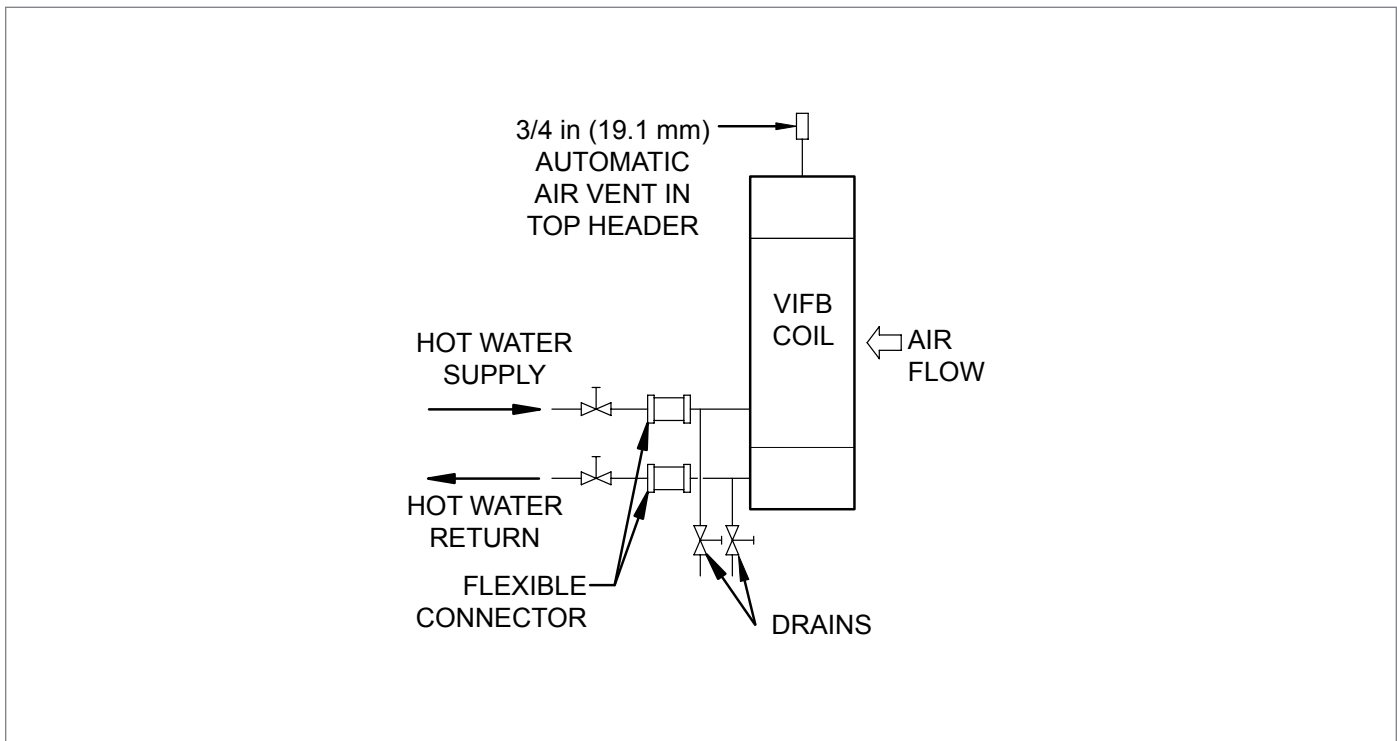
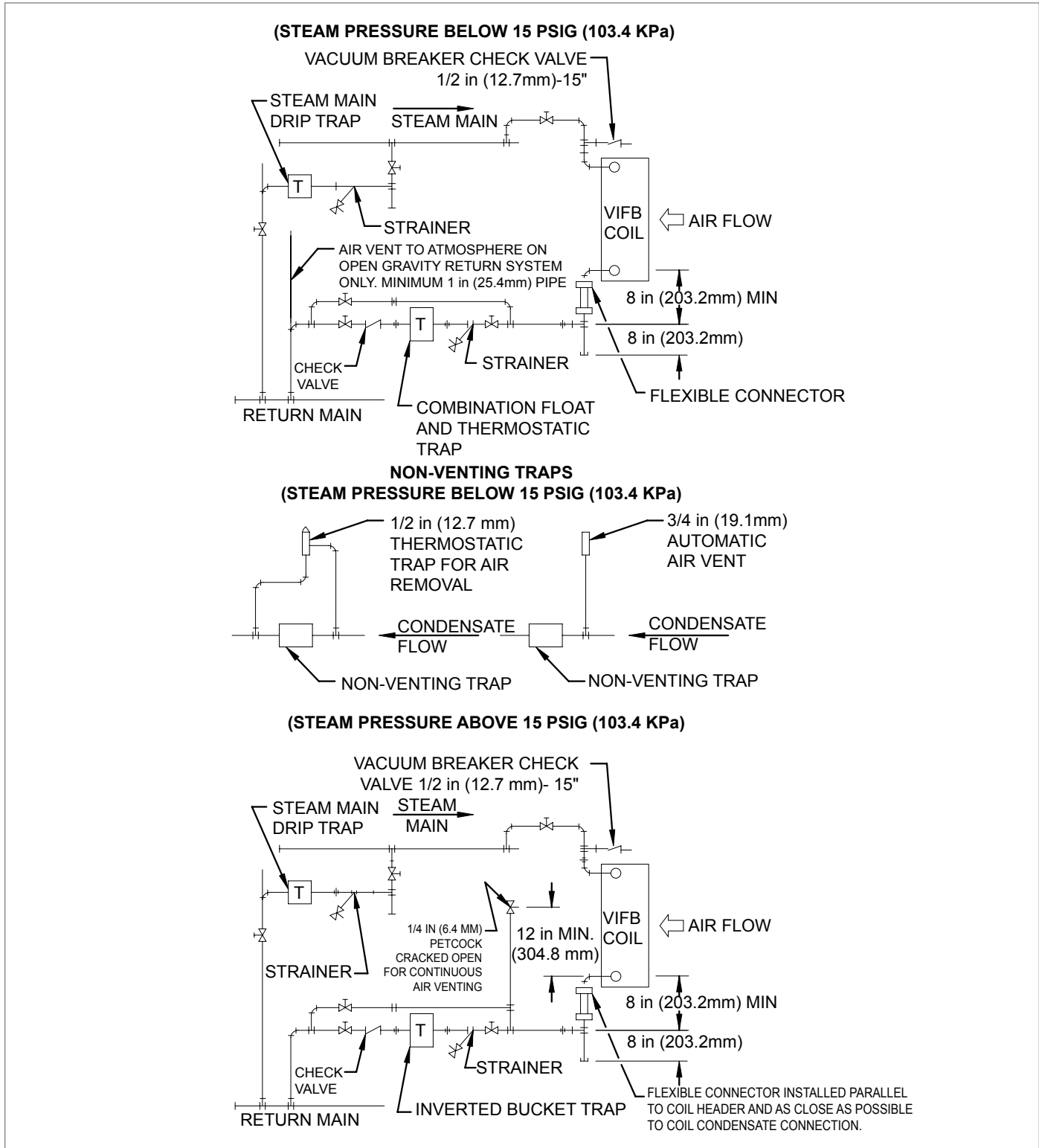

FIGURE 88 - HOT WATER PIPING SCHEMATIC FOR 2-ROW COIL VIFB



SECTION 3 - HANDLING, STORAGE, & INSTALLATION (CONTINUED)

FIGURE 89 - STEAM PIPING FOR VIFB



SECTION 3 - HANDLING, STORAGE, & INSTALLATION (CONTINUED)

REFRIGERATION

DX Direct Expansion Coils

DX coils are often divided into splits, depending upon the AHU size and coil circuiting. Each split requires its own distributor nozzle, expansion valve and suction piping. Suction headers are on the air entering side with suction connection at the bottom end of the headers when the coil is properly installed. Matching distributor connections for each coil refrigeration circuit are on the air leaving side. Refer to the drawing and/or connection labeling to ensure the suction and distributor connections are matched correctly.

Do not leave the piping open to the atmosphere unnecessarily. Water and water vapor are detrimental to the refrigerant system. Until the piping is complete, recap the system and charge with nitrogen at the end of each day. Clean all piping connections before brazing the joints.

The orientation of the refrigerant distributor is not critical, but the distributor tubes must not be kinked or bent in a non-uniform configuration. For other piping and sundry tips, refer to Figure 90 on the next page.

DX Coil Types

Three types of coil arrangements are used in field mounted split systems: interlaced, row split and face split.

Interlaced - These coils are the most desirable type of coil field mounted designs. Interlaced coils ensure the entire face of the coil is active with any number of operating compressors. Interlaced circuitry interweaves the coil tubing in both circuits across the entire face of the coil, assuring uniform cooling of the air by the refrigerant. This type of coil also allows one circuit to operate while the other circuit is turned off. Interlaced coils provide excellent temperature control at full and part loads as well as good thermal expansion valve (TXV) superheat control, which is essential for compressor reliability.

Row Split - Row split coils arrangements place coils back-to-back in the air stream. Air passes through one coil before passing through the next coil. Generally, the last coil in the air stream is activated first. Each circuit may be controlled independently in this arrangement. When both coils are operating, the coil closest to the leaving air will operate at a lower temperature. This type of coil may not permit lead lag of the circuits and it may be difficult to balance the capacity between the coils.

Face Split - On this coil, the circuiting is divided between two separate coils. In field mounted systems, this arrangement may suffer from TXV superheat control problems and compressor reliability. At low airflow, low load situations, the TXV may have difficulty controlling the system's superheat.

Air stratification, poor humidity control, and condensation on downstream components can also occur when using face split coils. One way to address TXV control at part load is to provide a face damper to shut off airflow when a coil face is inactive.

Combined Coil Types

Coil types may be combined in some systems, which requires special care. Control sequences and piping tying the multiple systems and coils together should be well thought out. Advice from an experienced design engineer may be necessary.

DX Coil Circuiting

On many coil banks, two, or all three circuiting methods may be combined, depending upon the cooling capacity, and the level of control required. However, coil sections must be combined so that they provide full-face operation as shown in Figure 91 - DX Coil Circuiting Types on the next page.

Refer to drawings on page 55 for the available standard arrangements from Krueger.

SECTION 3 - HANDLING, STORAGE, & INSTALLATION (CONTINUED)

FIGURE 90 - TYPICAL PIPING AND SUNDRIES AT THE DX COIL

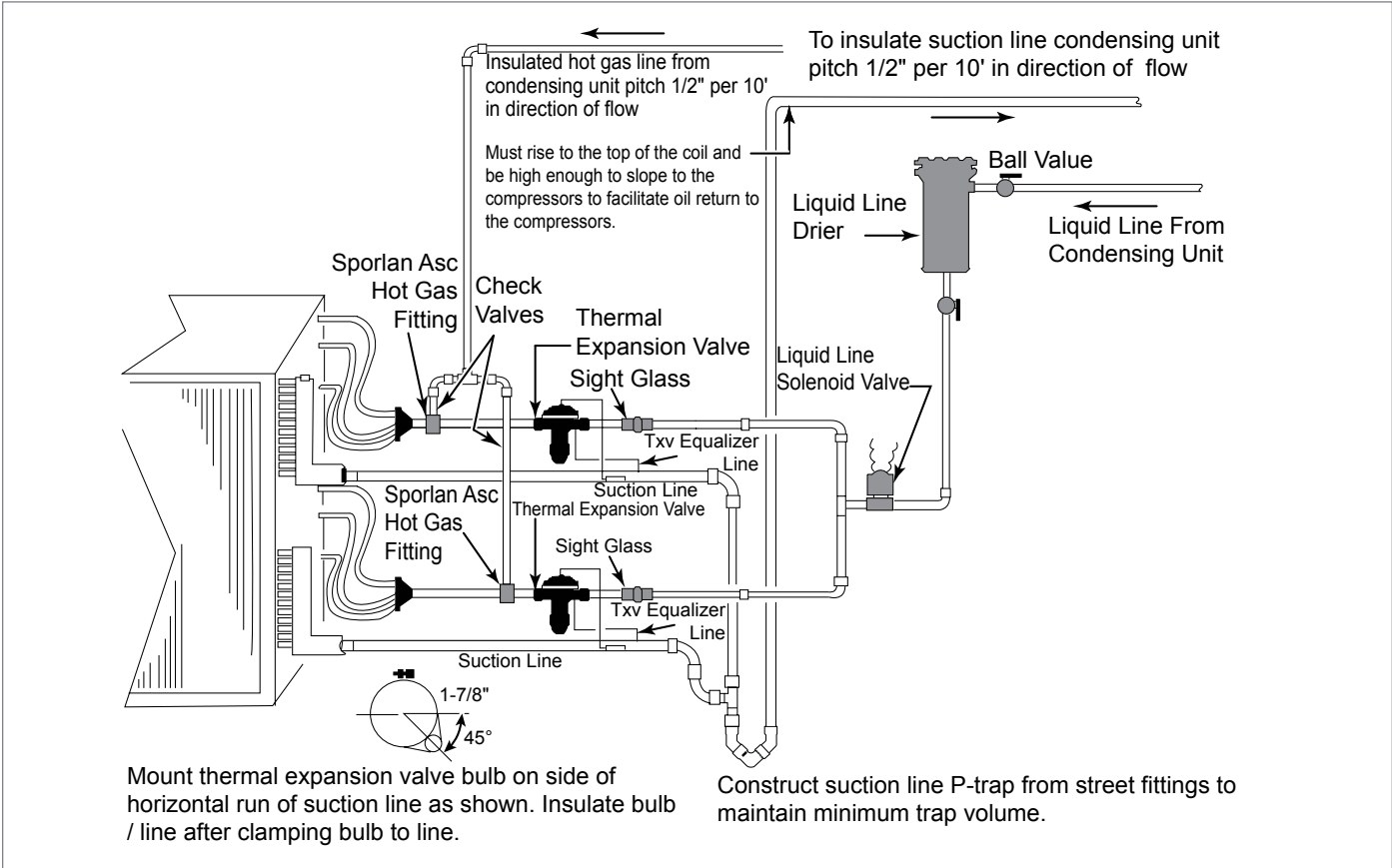
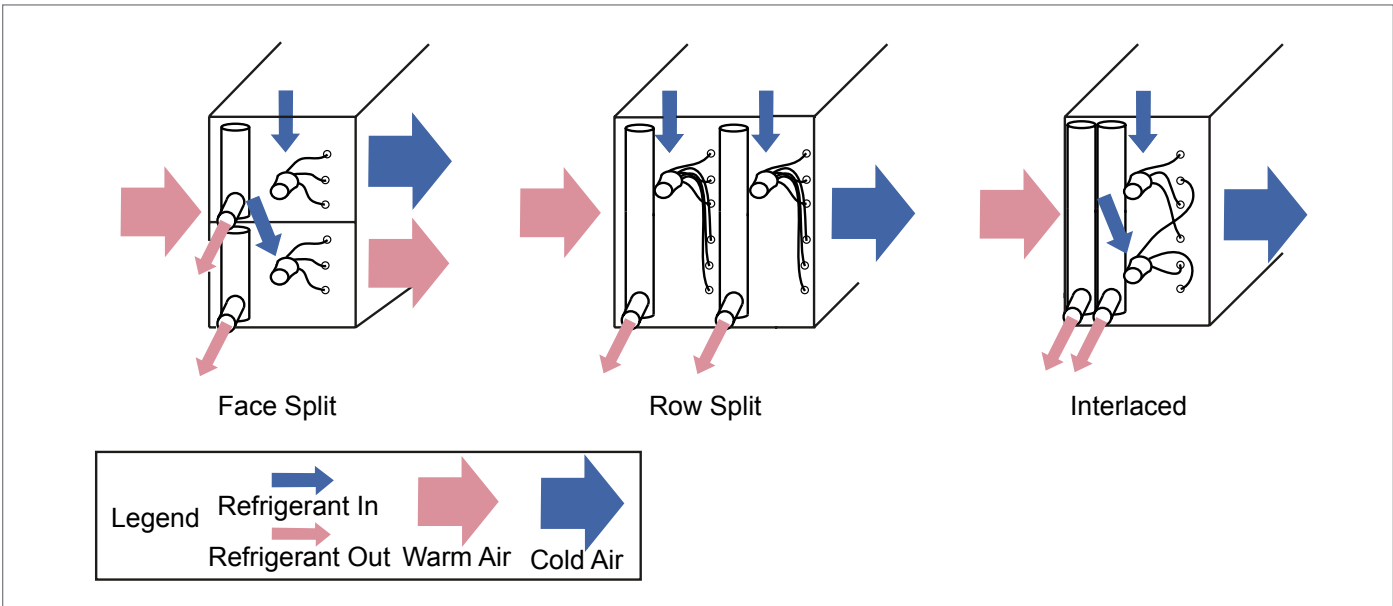
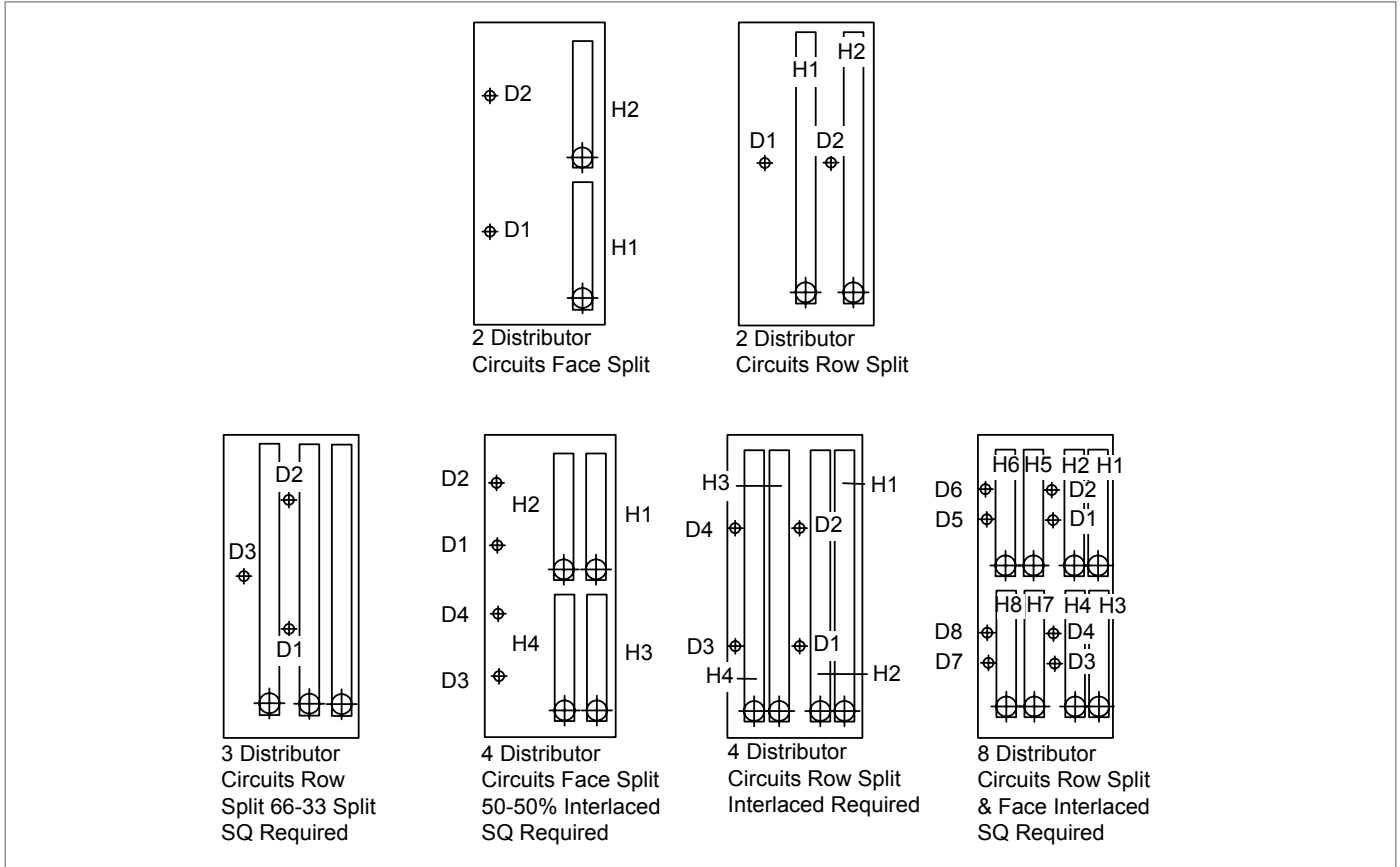

FIGURE 91 - DX COIL CIRCUITING TYPES



SECTION 3 - HANDLING, STORAGE, & INSTALLATION (CONTINUED)

FIGURE 92 - NON-STACKED COIL DESIGN (SPECIAL QUOTE)



Available Coil Arrangements

Figures 92 - 95 (above, through page 56) illustrate the available coil arrangements. Contact Krueger for other arrangements not shown.

Configure face-split DX coils to provide full-face coverage at all condensing AHU load steps. Krueger assumes no responsibility for compressor failure, if full face coverage is not applied. Consult Krueger if application assistance is needed to convert the split face to a full face operation.

FIGURE 93 - NON-STACKED COIL DESIGN (STANDARD)

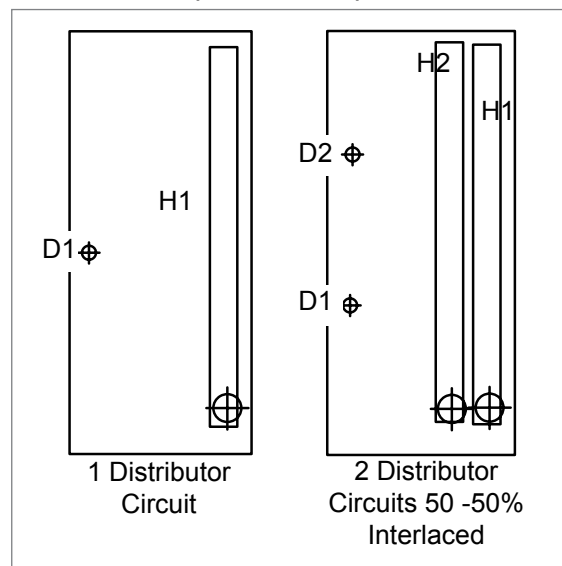
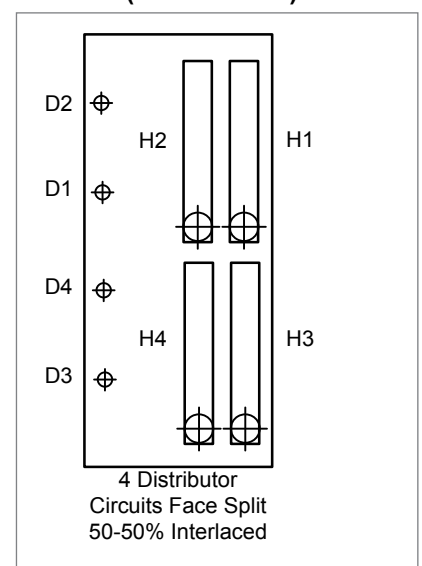
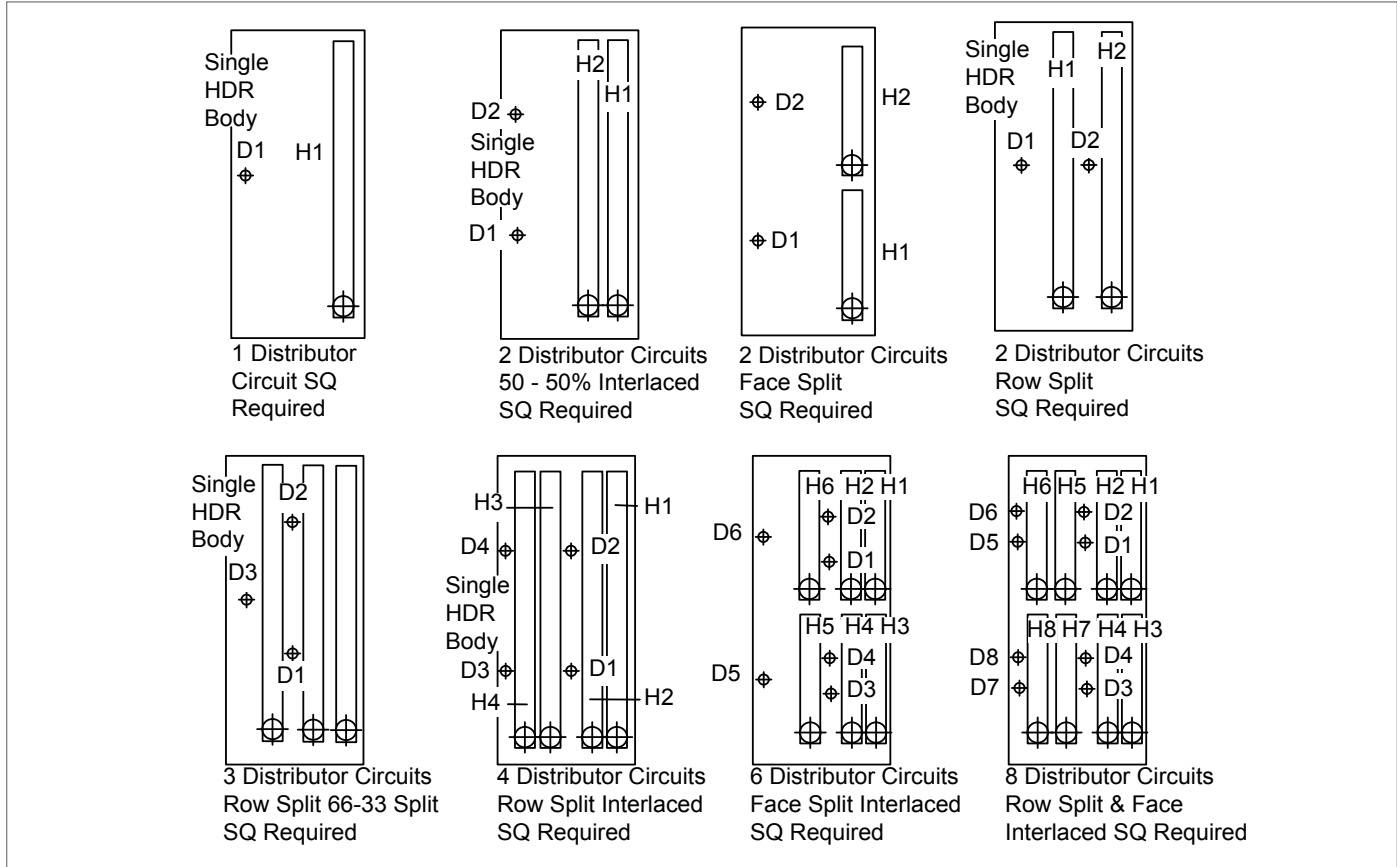

FIGURE 94 - STACKED COIL DESIGN (STANDARD)



SECTION 3 - HANDLING, STORAGE, & INSTALLATION (CONTINUED)

FIGURE 95 - NON-STACKED COIL DESIGN (SPECIAL QUOTE)



THERMOSTATIC EXPANSION VALVES (TXV)

Each coil distributor circuit requires its own thermal expansion valves (TXV), and condensing AHU circuit requires its own liquid line solenoid valve (LLSV). Equip TXVs with external equalizer tubes that are field connected to the suction line. Size the valve according to the valve manufacturer's recommendations, allowing approximately 35 psi (throughout the coil and distributor at full load).

Do not oversize the valve. Follow the valve manufacturer's instructions to find the thermostatic bulb. Proper expansion valve operation is necessary in order to realize the rated coil capacity.

When a DX type coil is operated with a suction temperature below 32°F, a buildup of frost will occur on the finned surface. It is not recommended to operate DX coils for air conditioning purposes at below freezing suction temperatures. If the full load operating point for the coil is selected at a safe temperature, a system analysis is required to check for the lowest probable suction temperature at light load conditions.

HOT GAS BYPASS (HGBP)

When using discharge air temperature control or systems with outside air economizer cooling, always include hot gas bypass (HGBP). It is not as critical to use HGBP with return duct air temperature or suction pressure control, but it provides better capacity control at low loads.

The Venturi type distributor furnished with the DX coils may be ordered for field application of an HGBP. The connection may be made through a tee installed in the field between the expansion valve and distributor. The system balance point and control adjustments must assure compressor cooling and avoid excessive compressor cycling.

SECTION 3 - HANDLING, STORAGE, & INSTALLATION (CONTINUED)

DX COIL CIRCUITING AND STAGING

On stacked coils, use a minimum of four coil circuits to achieve full face control as shown in Figure 96 (right). When the condensing AHU has two compressors per refrigerant circuit, one or two coil circuits may be used for each refrigerant circuit, depending upon the cooling capacity.

If one coil circuit is used as shown in Figure 97 (right), the LLSV and TXV must be sized to handle the full capacity of the refrigerant circuit. When two coil circuits are used per refrigerant circuit as shown in Figure 98 (right), each TXV should be sized to handle half of the capacity of the refrigerant circuit, and the LLSV should be sized to handle the full capacity of the refrigerant circuit.

When the condensing AHU has three compressors per circuit, use two coil circuits for each refrigerant circuit as shown in Figure 99 (right). Each coil circuit must have a dedicated TXV and distributor to handle one coil circuit, and the LLSV should be sized to handle the full capacity of the refrigerant circuit. Connect the HGPB line to all distributors in the coil circuit.

In a stacked coil with four coil circuits piped to a condenser with six compressors, the coil circuits would be face split and interlaced with two interlaced circuits on the lower coil section and two on the upper section as shown in Figure 100 on the next page.

When sizing TXVs, size the TXV for the refrigerant circuit tonnage divided by the number of DX coil liquid distributors, which should be equal to or smaller than the calculated value.

The first three compressors would be tied into LLSV1, TXV1 and TXV2, which would provide full face control of the coil at the lowest cooling loads. Both distributors on each coil circuit would include auxiliary side connectors for HGPB.

The second set of three compressors would be tied into LLSV2, TXV3 and TXV4 to maintain full-face control at higher loads.

FIGURE 96 - STACKED COIL CIRCUITING

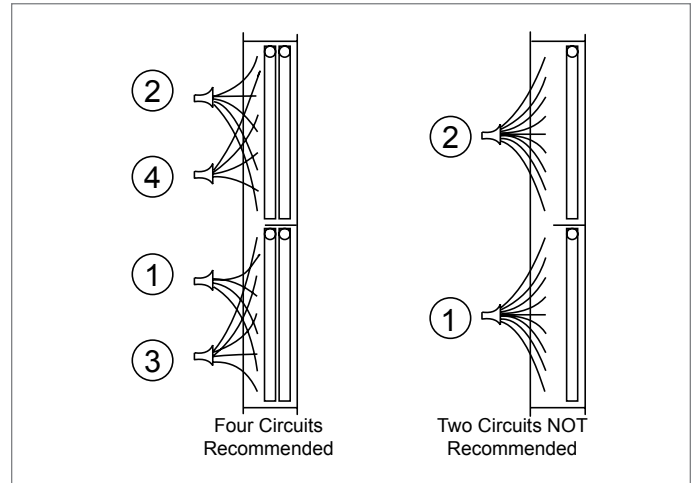

FIGURE 97 - ONE COIL CIRCUIT PER REFRIGERANT CIRCUIT

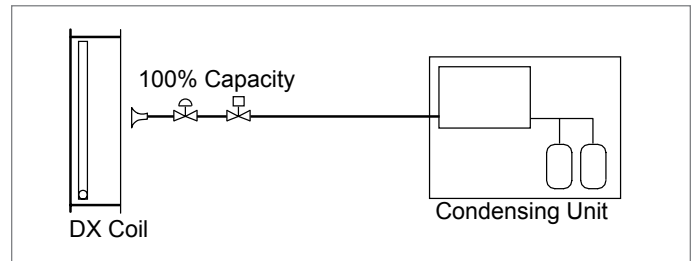

FIGURE 98 - TWO COIL CIRCUIT PER REFRIGERANT CIRCUIT

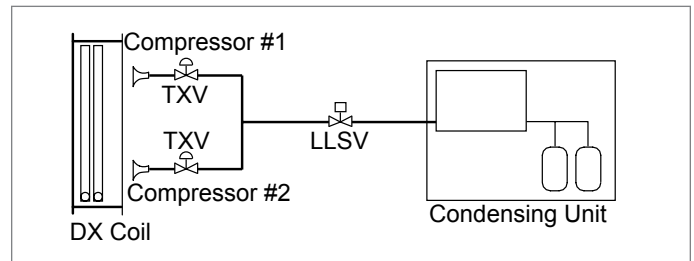
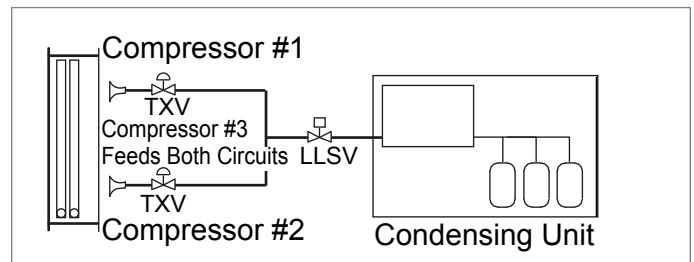
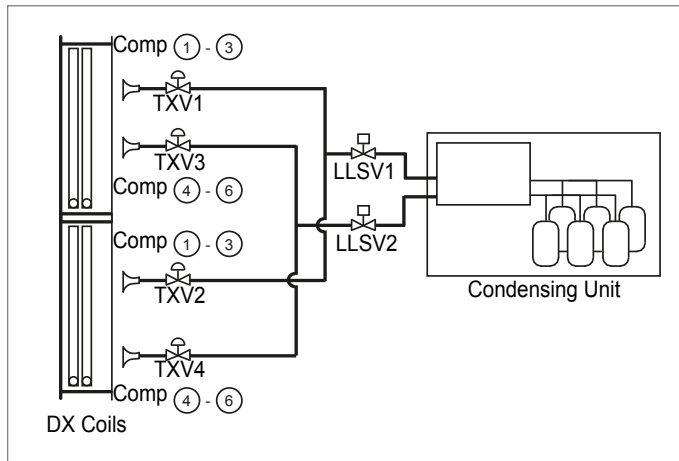

FIGURE 99 - THREE COMPRESSOR UNIT



SECTION 3 - HANDLING, STORAGE, & INSTALLATION (CONTINUED)

FIGURE 100 - STACKED COIL CIRCUITING



Advantages of Multiple Control Stages

The more control stages used, the more precise the control of the air temperature will be. Smaller incremental changes in capacity will result in a more consistent DX coil leaving air temperature, which will eliminate temperature swings in the conditioned space and improve the comfort level. But more importantly, a consistent space temperature is crucial to many process applications.

The smaller changes in capacity that result from using a greater number of control stages will also extend equipment life. The most important thing to remember is to maintain full-face control of the coil at all cooling loads. When row split coils are used, make sure that the first LLSV is energized with the last coil circuit in the leaving air stream, which is always the last one deenergized too.

MAINTAINING ADEQUATE AIRFLOW

An electrical interlock between the AHU and the condenser must be included for permissive run of the condenser. In addition, a differential pressure switch mounted across the supply fan must always be included to ensure airflow across the coil before the condensing AHU is energized. The condenser must never be operated unless the AHU fan is operating and air is flowing across the active coil. Insufficient airflow will result in liquid refrigerant returning to the condensing AHU, which could damage the compressors by liquid slugging or washing oil from the bearing surfaces.

In variable volume systems, the minimum acceptable airflow for fixed speed or variable air volume (VAV) systems is 350 FPM face velocity across each DX coil, as applied to split DX systems. Make sure that the TXV does not overfeed, because it could cause compressor failure.

The air velocity flowing through chilled water and direct expansion coils must not exceed specific recommended values to prevent water carryover.

VAV SYSTEMS

Overhead VAV systems are the preferred method of air distribution because they offer greater energy efficiency and better control of building diversity than constant volume systems (CVS). Unlike a CVS, in which the leaving air temperature is adjusted to satisfy the cooling load, the air temperature in a VAV system remains constant, and the air volume is varied to meet the cooling requirements.

A VAV system has four components:

1. AHU with airflow control (i.e. Variable Frequency Drives (VFDs)),
2. VAV boxes,
3. Zone thermostats, and
4. Duct static pressure sensors.

These components must work together to provide good temperature control, and a comfortable environment.

The zone thermostats control the VAV boxes. As the zone temperature increases, the VAV boxes open to allow greater airflow into the space. As the zone temperature decreases, the VAV boxes close to decrease the airflow to the space.

As the VAV boxes open and close, the static pressure in the ductwork changes. When a box opens, the duct static pressure decreases, and when a box closes, the duct static pressure increases. The duct static pressure sensor controls the AHU supply fan. Since an increase in duct pressure relates to a decrease in the required zone airflow, the supply fan volume decreases. Conversely, a lower duct static pressure indicates a need for increased zone airflow; the supply fan volume increases. A change in supply air volume is accomplished using a VFD or similar device.

In the AHU, a decrease in airflow through the DX coil will result in a corresponding decrease in the suction gas pressure while an increase in airflow will result in an increase in the suction gas pressure. Since the system is designed to maintain a constant suction gas pressure, the compressors will be turned on or off, as needed, to meet the increase or decrease in load demand. The system should be designed to operate smoothly, avoiding transients that could upset system balance and cause liquid flood back.

SECTION 3 - HANDLING, STORAGE, & INSTALLATION (CONTINUED)

! **CAUTION** - Problems can arise if the airflow decreases more quickly than the compressor control can respond to the load change. Therefore, airflow should never change at a rate faster than 3% per minute on VAV systems.

This limitation will promote stable control of the system and minimize fluctuations in zone temperature. Under any circumstances, a minimum of 350 FPM face velocity across the coil must be maintained for DX split systems.

DRAINS AND TRAPS

! **CAUTION** - Where there is a risk of the liquid freezing in the trap, heat trace and insulate the traps to prevent blockage and/or damage. Auxiliary drain pans may not require traps. If the trap is not in constant use, the water seal may evaporate, causing air passage into or out of the AHU. In these cases, it is recommended to cap the drain that allows the opening or closing of the drain, depending on its use.

Condensate Drain Piping

The majority of cooling coils are located in the AHUs, so that the supply air is drawn through them, which results in the condensate being subjected to negative (-) static pressure. Unless pressure equalization is provided in the condensate drain, the air rushing back through the drain pipe will cause the condensate to build up in the drain pan.

As the AHU continues to operate, the accumulated water will be carried with the air stream, overflowing the drain pan, causing possible water leaks into the supply duct and/or causing water damage in the building. Install a trap to prevent this condensate water buildup as shown in Figures 101 and 102 (right).

Condensate Drain Trap

For Draw Through applications, install a trapped condensate drain line at the AHU drain connection as shown in Figure 101 - 102 (right), according to all codes. The H dimension must be at least 1" greater than the design TSP of the fan, which ensures proper drainage even if filters clog or dampers malfunction.

For Blow Through applications, the same principles apply, but the leaving pipe should be as shown in Figure 103 on the next page for proper trap design.

Two or more drains on the same side of AHU must be trapped individually before the drain lines can be combined and routed to a suitable drain as shown in Figure 104 on the next page.

If the distance from the drain pan outlet to the trap exceeds 10 ft, install additional clean outs for each 10 ft segment of horizontal drain line (min. 1/4" per foot fall required). On initial start-up, it may be necessary to fill the trap manually.

Elevating AHU for Gravity Floor Drain Connections

On indoor AHUs, the installer must provide a method to pump or drain the coil condensate water away from the AHU. The installer may have to elevate the AHU to provide space below the condensate drain of the AHU to properly install the designed drain trap(s) to permit gravity flow of condensate water from the drain pan as shown in Figures 15-17 on page 14.

FIGURE 101 - DRAIN TRAP SHOWING WATER LOCATION FOR DRAW THROUGH OPERATION

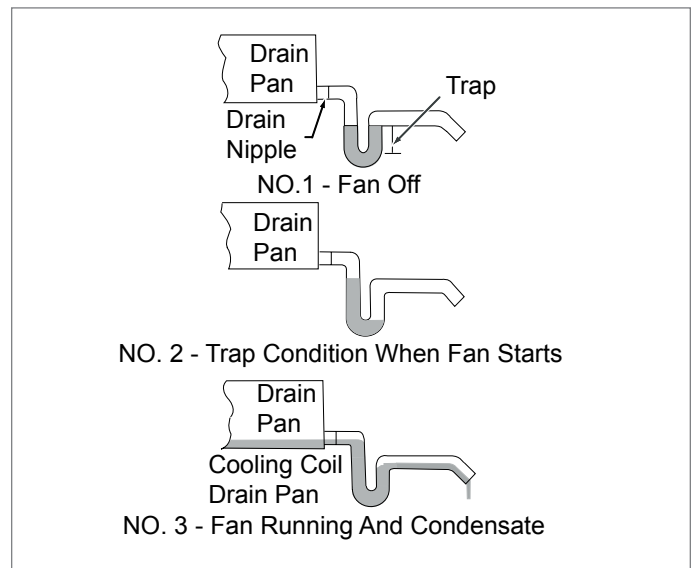
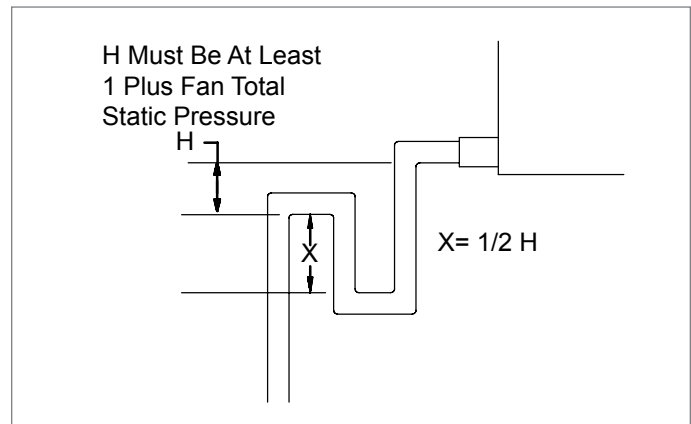

FIGURE 102 - TRAP DETAIL FOR DRAIN PAN IN NEGATIVE ENVIRONMENT (DRAW THROUGH)



SECTION 3 - HANDLING, STORAGE, & INSTALLATION (CONTINUED)

FIGURE 103 - TRAP DETAIL FOR DRAIN PAN IN POSITIVE ENVIRONMENT (BLOW THROUGH)

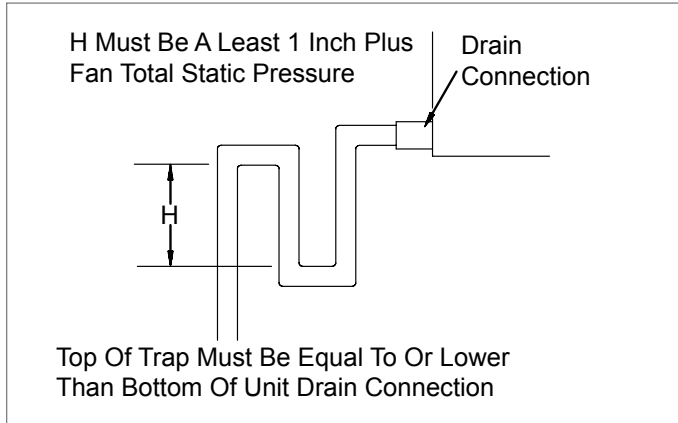

FIGURE 104 - COMBINING DRAIN LINES

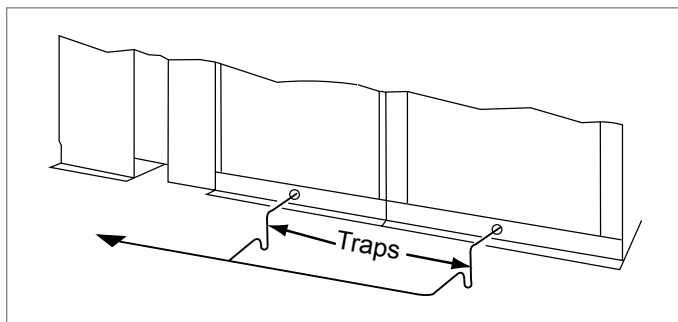
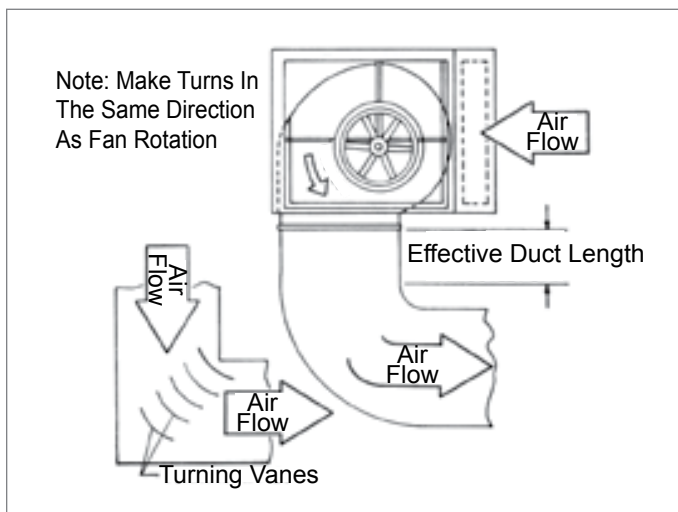

FIGURE 105 - RECOMMENDED DISCHARGE DUCT ARRANGEMENT WHEN TURNS ARE REQUIRED



DUCT CONNECTIONS

The duct must have positive seal to the AHU openings. Base rails are available in 3", 6", 8", or 10" height. It's the contractor's responsibility to provide the ductwork, which includes the base rail height, and support it independently from the AHU.

Duct Connection Guidelines

The duct connection guidelines are as follows:

- Duct connections to the AHU may be made directly except when the AHU has external isolation. Then the duct connections should be made with flexible material, and be installed so they are sufficiently loose.
- Duct connections should be designed and installed according to AMCA Standards 200 and 201, at a minimum.
- Duct turns and transitions must be made carefully to hold friction loss to a minimum. Avoid short turns. Duct elbows should contain splitters or turning vanes.
- The effective duct length connected to the fan or AHU discharge should run in a straight line for at least 2.5 equivalent discharge diameter for up to 2500 FPM fan outlet velocity and one additional diameter for each additional 1000 FPM fan outlet velocity.
- Ductwork should be no greater than 105.5% or no less than 85.5% of the discharge area. The slope of the transition elements should not be greater than 15% for converging elements, or greater than 7% for diverging elements.
- To find the equivalent discharge diameter, use the following equation, where a = height, and b = width of the discharge: $EDD = \sqrt{4ab / \pi}$
- A duct turn should be in the same direction as the fan rotation as shown in Figure 105 (left). Never deadhead the discharge into the flat surface of a plenum.

Flanged Duct or Sleeves

To use flanged ducts or sleeves, make sure there is access on all four sides to fasten the flange completely.

Connect the flanged ducts with self-drilling screws directly to the AHU with a gasket or sealant between the AHU, and the duct flange as shown in Figure 106 on the next page. A flange may be dropped through the opening, if there is access to seal and fasten the flange to the AHU's interior surface.

SECTION 3 - HANDLING, STORAGE, & INSTALLATION (CONTINUED)

Raw or Straight Edge Duct or Sleeves

The duct opening on the AHU is located in a panel about 2" thick, which is suitable for attaching ducts.

If access is not available from the inside of the AHU, access may have to be gained from inside of the duct or sleeve.

Connect the raw or straight edge ducts with the self drilling screws directly to the AHU with a gasket or sealant between the AHU and the duct flange as shown in Figure 106 (below).

The performance ratings of coils will be met only if the airflow is uniform over the face of the coils. High air velocity spots on the coil may cause carryover of moisture from the coil. High or low air velocity areas of the coil will not deliver the published ratings. The duct connections must be designed to provide for uniform flow of air across the face of the coil. The entering duct must provide a smooth transition from any high velocity effects. Stratifications of outside and return air, especially where below freezing outside air enters, must be avoided to prevent coil freeze-up or nuisance low limit trips.

FIGURE 106 - DUCT ARRANGEMENT FOR FLANGE AND RAW EDGE DUCTS

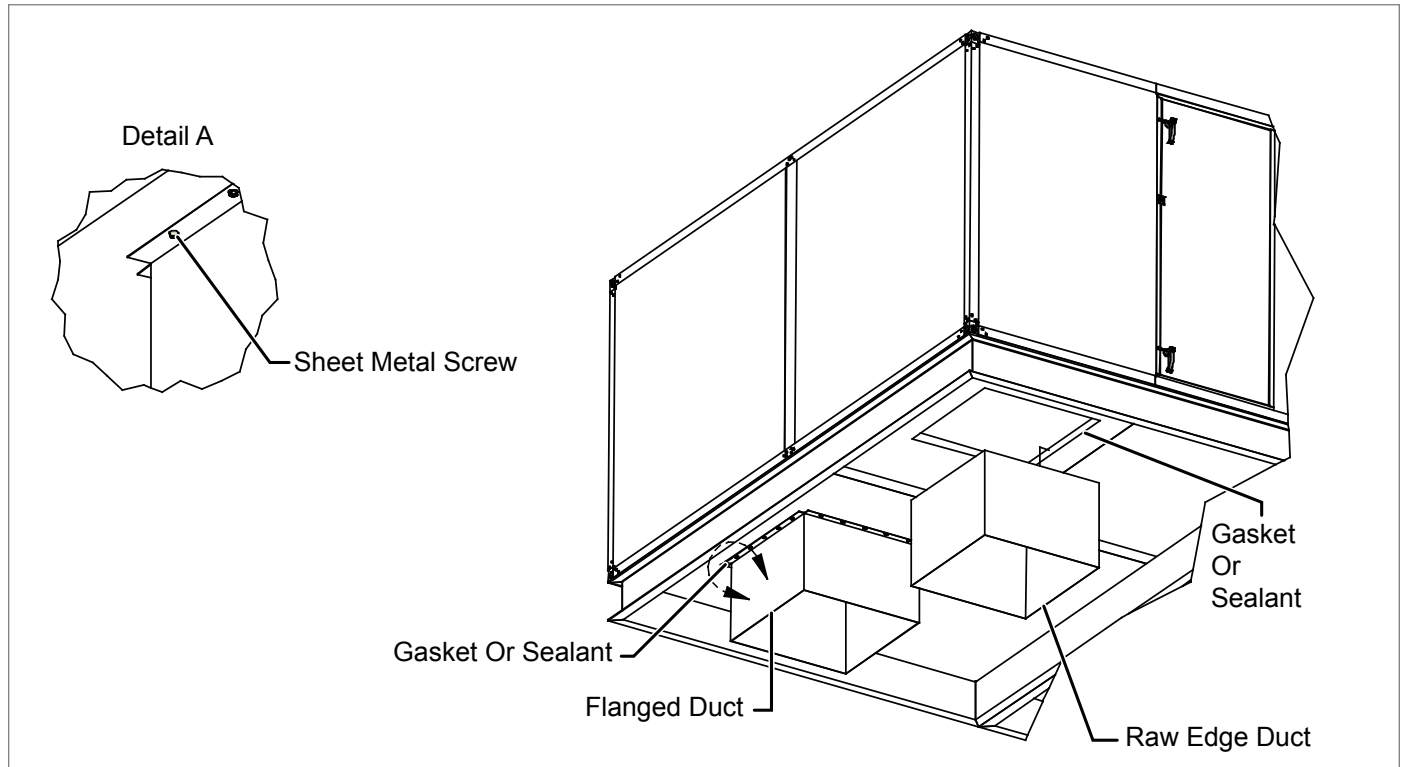

Sound and Vibration Transmission

All roof-mounted AHUs generate some sound and vibration, which may or may not require special treatment of the air-conditioned space. The noise generated by the AHU depends on the following:

- Speed of the fan,
- Amount of air the fan is moving,
- Fan type, and
- Static efficiency of the fan.

In applications where sound and vibration transmissions may be objectionable, good acoustical engineering practices must be incorporated in the system design. On AHUs with return fans, it is important to consider the effects of sound transmission into the airconditioned space.

When a AHU is used with a ceiling plenum return air system, sound may be transmitted from the AHU through the ceiling to the air-conditioned space. For such applications, install a sound absorption chamber near the AHU return air inlet. Various reference sources are available regarding acoustic design.

SECTION 3 - HANDLING, STORAGE, & INSTALLATION (CONTINUED)

AIR FILTERS

Filters MUST be in place in the filter frames before putting the AHU into operation to protect and keep the coils clean. Due to the wide variety of filters, it is not possible to cover all filter types. Refer to Figures 108a-e on this and the next page for typical filter types.

Install the filters in the correct orientation with regard to airflow and with pleats or pockets vertically, wherever possible. Refer to the AHU Operation and Maintenance Manual for more information.

Most AHUs will be shipped without filters. The local Krueger Representative is responsible for ordering and delivering the filters in a timely manner. The contractor or commissioning agent must contact the Krueger Representative regarding this issue because various filter types will have different lead times.

Filter latches as shown in Figures 108a-e on this and the next page, if required, will be shipped with the first filter shipment.

The contractor is responsible for installing the filters, and for freight claim, if the filters arrive damaged. Address other issues such as size, type, spares, replacements, or quantity with the local Krueger Representative. Filter types are:

- Flat
- Angle
- Rigid
- Charcoal

Maintaining and Replacing Filters

Every month, check the cleanliness of the filters and replace, if necessary. Replace the filters when the pressure, measured by a manometer, reaches the prescribed limits for the installation.

FIGURE 107 - TYPICAL FILTER TYPES

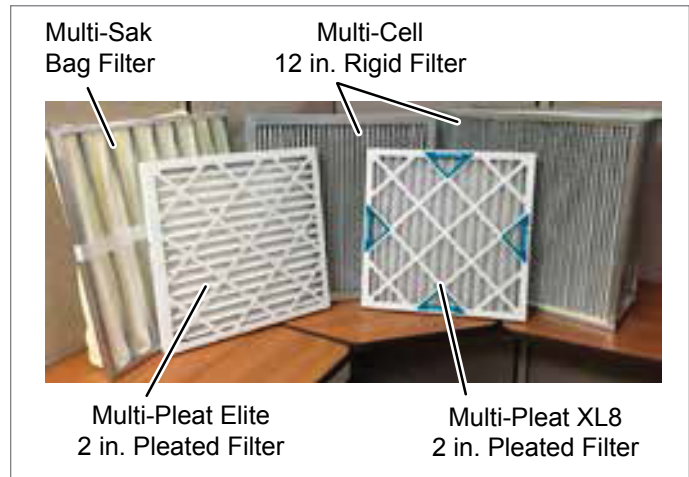
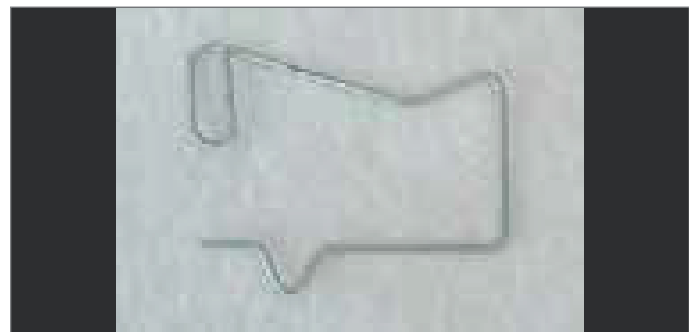

FIGURE 108a - FILTER LATCH - P/N 026-35788-702



Used with 2" Pre-filter and SH Single Header Final Filters.

FIGURE 108b - FILTER LATCH - P/N 026-35788-604 (C86) & 026-35788-605 (C89)



Used with 2" (C86) and 4" (C89) Pre-Filter Combined with a Single Header Final Filter.

SECTION 3 - HANDLING, STORAGE, & INSTALLATION (CONTINUED)

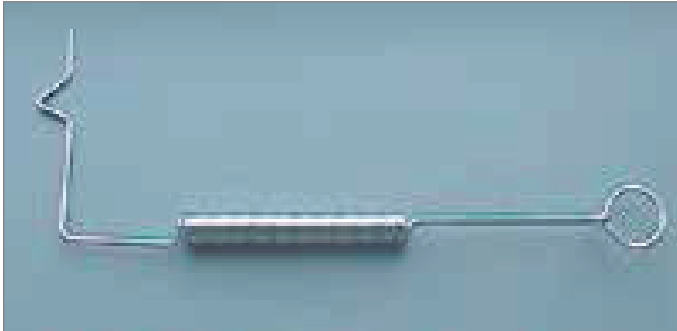
FIGURE 108c - FILTER LATCH - P/N 026-35788-612

Used with 2" and 4" Pre-Filter Combined with a Double Header (DH) Final Filter.

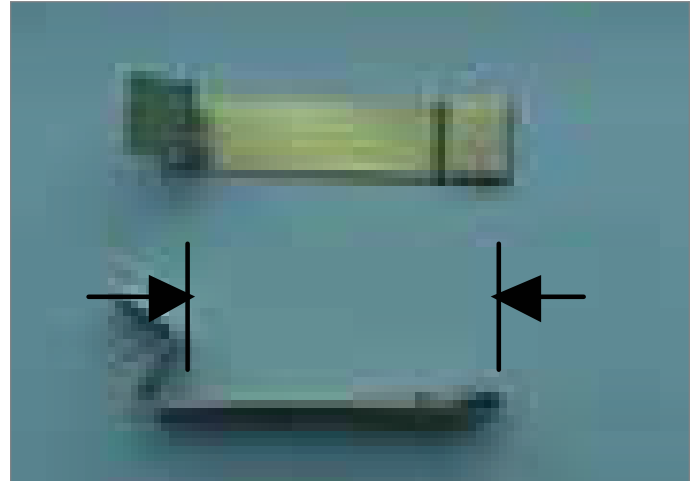
FIGURE 108d - FILTER LATCH - P/N 026-35788-625

Used with 2" Pre-filter Combined with a DH Final Filter.

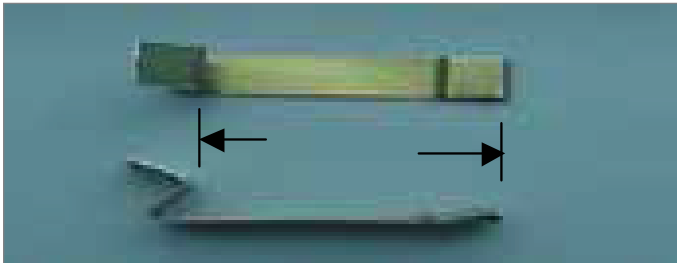
FIGURE 108e - FILTER LATCH - P/N 026-35788-626

Used with 4" Pre-filter Combined with a DH Final Filter.

TABLE 6 - KOCH FILTER CLIPS - SINGLE FILTER APPLICATION

PART NUMBERS	2" MICROMAX	4" MICROMAX	MULTI-CELL FM SINGLE HEADER (SH) OR MULTI-SAK	MULTI-CELL SBM DOUBLE HEADER (DH)
026-35778-702	X	-	X	-
026-35778-604	-	X	-	-
026-35778-612	-	-	-	X

TABLE 7 - KOCH FILTER CLIPS - PRE-FILTER / FINAL FILTER APPLICATION

PART NUMBERS	2" MULTI-PLEAT ELITE OR CLEANABLE OR THROWAWAY AND MULTI-CELL FM SINGLE HEADER (SH) OR MULTI-SAK	2" MULTI-PLEAT ELITE OR CLEANABLE OR THROWAWAY AND MULTI-CELL SBM DOUBE HEADER	4" MULTI-PLEAT XL8 AND MULTI-CELL FM SINGLE HEADER (SH) OR MULTI-SAK	4" MULTI-PLEAT ELITE AND MULTI-CELL SBM DOUBLE HEADER
026-35778-702 026-35778-604	X	-	-	-
026-35778-612 026-35778-625	-	X	-	-
026-35778-702 026-35778-605	-	-	X	-
026-35778-612 026-35778-626	-	-	-	X

When filters are supplied by other companies, the filter clips are supplied as well.

SECTION 3 - HANDLING, STORAGE, & INSTALLATION (CONTINUED)

Filter Installation

Installing a 2" Pleated Filter

Use the following instructions to install a 2" Multi-Pleat Elite filter into a 16 gauge galvanized holding frame with four latches (P/N 026-35788-702), as shown in Figures 108a-e on pages 62-63.

1. Install one latch at each corner (4 corners) of the frame. The latch fits into two rows of three knockouts. Use the row of knockouts closest to the gasket for nominal 1" filters or filters with a 13/16" single header. Use the second set of knockouts for nominal 2" filters.
2. Insert the straight end of the latch between the two knockouts furthest from the corner.
3. Using a moderate amount of pressure, force the latch over the third knockout. The latch should now be trapped within the three knockouts, but should be able to freely rotate as shown in Figure 109 (right).
4. The latch installation should be complete.
5. Install the other three latches into the corners.
6. Rotate all of the latches outward, and insert the filter into the frame.
7. Grasp the circular end of the latch, and rotate it across the corner of the filter.
8. Push the end of the latch towards the filter until the latch catches beneath the knockout on the frame.
9. Repeat the process with the remaining latches.
10. The filter should now be securely installed into the frame as shown in Figure 110 (right).

FIGURE 109 - CORRECTLY INSTALLED LATCH PIN (P/N 026-35788-702)

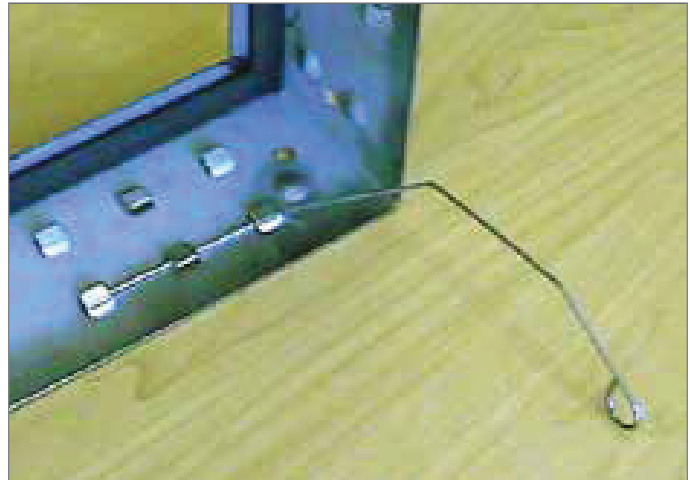
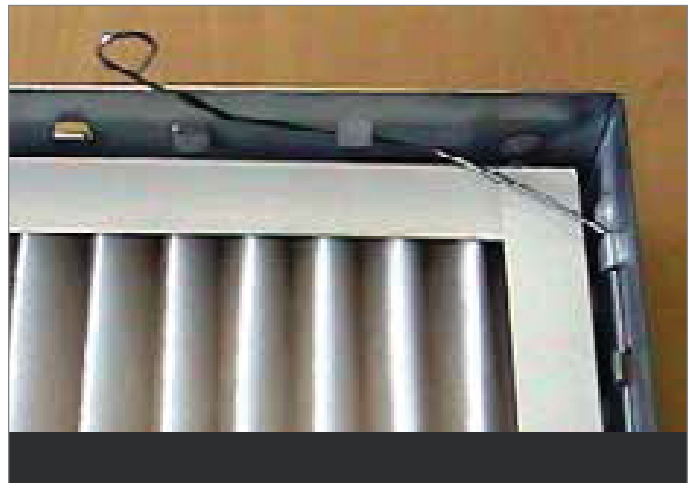

FIGURE 110 - FULLY INSTALLED FILTER



SECTION 3 - HANDLING, STORAGE, & INSTALLATION (CONTINUED)

Installing a 4" Pleated Filter

Use the following instructions to install a 4" Micro-MAX filter into a 16 gauge galvanized holding frame with four latches (P/N 026-35778-604), as shown in Figures 108a-e on pages 62-63.

1. Install one latch at each corner (4 corners) of the frame. The latch fits into two rows of three knockouts. Use the row of knockouts closest to the gasket for nominal 1" filters or filters with a 13/16" single header. Use the second set of knockouts for nominal 2" filters.
2. Insert the straight end of the latch between the two knockouts furthest from the corner.
3. Using a moderate amount of pressure, force the latch over the third knockout. The latch should now be trapped within the three knockouts, but should be able to freely rotate as shown in Figure 111 (right).
4. The latch installation should now be complete.
5. Install the other three latches into the corners.
6. Rotate all of the latches outward, and insert the filter into the frame.
7. Grasp the loose end of the latch, and place it over the filter frame so that the latch secures the filter into the frame as shown in Figure 112 (right).
8. Repeat the process with the remaining latches.
9. The filter should now be securely installed into the frame.

FIGURE 111 - CORRECTLY INSTALLED LATCH PIN (P/N 026-35788-604)



FIGURE 112 - PLACE THE END OF THE LATCH OVER THE FILTER FRAME



SECTION 3 - HANDLING, STORAGE, & INSTALLATION (CONTINUED)

Installing a Single Headered (SH) Filter

Use the following instructions to install a 2" Single Headered (SH) filter into a 16 gauge galvanized holding frame with four latches (P/N 026-24788-702), as shown in Figures 108a-e on pages 62-63.

1. Install one latch at each corner (4 corners) of the frame. The latch fits into two rows of three knockouts. Use the row of knockouts closest to the gasket for nominal 1" filters or filters with a 13/16" single header. Use the second set of knockouts for nominal 2" filters.
2. Insert the straight end of the latch between the two knockouts furthest from the corner.
3. Using a moderate amount of pressure, force the latch over the third knockout. The latch should now be trapped within the three knockouts, but should be able to freely rotate.
4. The latch installation should be complete.
5. Rotate the latches outward, and insert the SH filter into the frame. Insert the bulk of the filter through the frame, protruding out the backside. Only the header of the filter should be contacting the flange of the frame.
6. After the filter is placed into the frame, grasp the circular end of the latch and rotate it across the corner of the filter.
7. Push the end of the latch towards the filter, until the latch catches beneath the frame knockout.
8. Repeat the process with the remaining latches.
9. The filter should now be securely installed into the frame as shown in as shown in Figure 113 (below).

FIGURE 113 - CORRECTLY INSTALLED CARTRIDGE FILTER

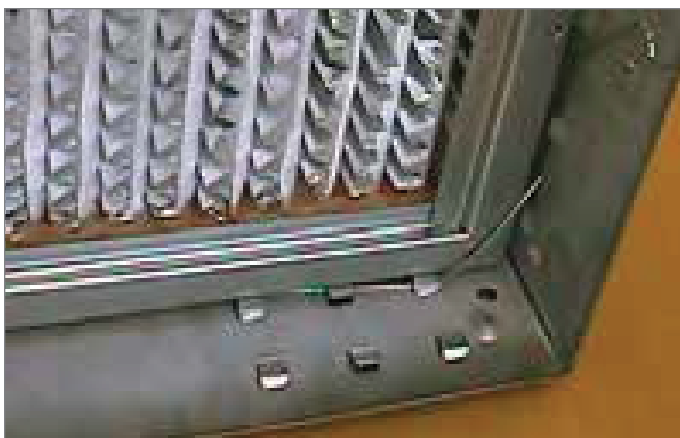

Installing a 2" Pre-Filter Combined with a Final Filter

Use the following instructions to install a 2" prefilter combined with a SH final filter (Multi-Cell FM Single Header or Multi-Sak) into a 16 gauge galvanized holding frame with four latches (P/N 026-35778-604), as shown in Figures 108a-e on pages 62-63.

1. Follow the instructions for the SH filters on the previous page, and then proceed with the following instructions for 2" pre-filters.
2. Insert the straight end of the latch between the two knockouts furthest from the corner.
3. Using a moderate amount of pressure, force the latch over the third knockout as shown in Figure 114 (below).
4. Grasp the loose end of the latch, and place it over the pre-filter frame, so that the latch secures the pre-filter to the SH filter.
5. Repeat the process with the remaining latches.
6. The filters should now be securely installed into the frame as shown in Figure 115 (below).

FIGURE 114 - CORRECTLY INSTALLED LATCH PIN (P/N 026-35788-604)



FIGURE 115 - CORRECTLY INSTALLED CARTRIDGE WITH PLEATS



SECTION 3 - HANDLING, STORAGE, & INSTALLATION (CONTINUED)

Installing a Multi-Cell SBM Double Headered (DH) Filter
 Use the following instructions to install a Multi-Cell SBM double header (DH) filter (nominal 12") into a 16 gauge galvanized holding frame with four latches (P/N 026-35788-612), as shown in Figures 108a-e on pages 62-63.

1. Install the two latches on each side of the frame. not on the top or bottom. Refer to the sets of knockouts in Figure 116 (below) that should be used for the latches.
2. Insert the straight end of the latch between the two knockouts furthest from the corner.
3. Using a moderate amount of pressure, force the latch over the third knockout.
4. The latch installation should be complete. The latch should now be trapped within the three knockouts.
5. Repeat the steps with the remaining latches. Note the orientation of the latch to the knockouts as shown in Figure 117 (right).
6. After the latches are installed, the frame should be configured as shown in Figure 118 - Frame with Four Latches Installed on the Sides (right), which shows there are two latches per side, none on the top or bottom.
7. Insert the Multi-Cell SBM DH filter into the frame. While holding the filter in the frame, grasp the loop on the end of the latch, and pull it until it stretches over the header, and rests into the predrilled hole in the header as shown in Figure 119 (right).
8. Repeat this step with the remaining latches.
9. The filter should now be securely installed into the frame.

FIGURE 116 - CORRECT USE OF KNOCKOUTS



FIGURE 117 - CORRECT LATCHOUT / KNOCKOUT CONFIGURATION



FIGURE 118 - FRAME WITH FOUR LATCHES INSTALLED ON THE SIDES



FIGURE 119 - SPRING LATCH PULLED AND FASTENED IN FILTER HOLE



SECTION 3 - HANDLING, STORAGE, & INSTALLATION (CONTINUED)

Installing a 2" and 4" Pre-Filter Combined with a DH Final Filter

Use the following instructions to install a 2" or 4" Multi-Pleat Elite or MicroMAX pre-filter combined with a Multi-Cell SBM DH (nominal 12" deep) final filter into a 16 gauge galvanized holding frame. Use the following latches to install the filter and pre-filter:

- Four spring latches (P/N 026-35788-612) to hold the Multi-Cell SBM DH into the frame,
 - Four pre-filter latches (P/N 026-35788-625) to hold the 2" latch, and
 - Four pre-filter latches (P/N 026-35788-626) to hold the 4" pre-filter onto the face of the Multi-Cell SBM DH filter.
1. Install the two latches on each side of the frame, not on the top or bottom.
 2. Insert the straight end of the latch between the two knockouts furthest from the corner.
 3. Using a moderate amount of pressure, force the latch over the third knockout.
 4. The latch installation should now be complete. The latch should now be trapped within the three knockouts as shown in Figure 120 (right).
 5. Repeat the steps with the remaining latches. Note the orientation of the latch to the knockouts as shown in Figure 120 (right).
 6. Insert the Multi-Cell SBM DH filter into the frame. While holding the filter in the frame, grasp the loop on the end of the latch, and pull it until it stretches over the header, and rests into the predrilled hole in the header as shown in Figure 121 (right).

FIGURE 120 - CORRECT LATCHOUT / KNOCKOUT CONFIGURATION (P/N 026-35788-612)



FIGURE 121 - SPRING LATCH PULLED AND FASTENED IN FILTER HOLE



SECTION 3 - HANDLING, STORAGE, & INSTALLATION (CONTINUED)

Installing Pre-Filter Latches

1. To install the pre-filter latches, slide the end of the latch with a 180° turn over the edge of the header, as shown in Figure 122 (right). Install the latch at the approximate midpoint of the filter leg. The pre-filter latch should be slid over the header as shown in Figure 122 (right).
2. Repeat the steps for the remaining pre-filter latches.
3. Place the pre-filter against the face of the Multi-Cell SBM DH filter. The pre-filter latches may have to be re-positioned as shown in Figure 123 (right), to allow the proper placement of the pre-filter.
4. Grasp the end of the pre-filter latch and spring it, so that it fits over the edge of the pre-filter as shown in Figure 124 (right).
5. Repeat this step with the remaining latches.

After placing all remaining pre-filter latches around the pre-filter; the finished assembly should look like the one shown in Figure 125 (below).

FIGURE 125 - COMPLETED ASSEMBLY



FIGURE 122 - INSTALLING PRE-FILTER LATCH



FIGURE 123 - POSITION PRE-FILTER IN FRONT OF FINAL FILTER



FIGURE 124 - SPRING END OF LATCH



SECTION 3 - HANDLING, STORAGE, & INSTALLATION (CONTINUED)

CONVERSIONS

TABLE 8 - SI METRIC CONVERSION

Measurement	Multiply English AHU	By Factor	To Obtain Metric AHU
Capacity	Tons Refrigerant Effect (Ton)	3.516	Kilowatts (kW)
Power	Horsepower	0.7457	Kilowatts (kW)
Flow Rate	Gallons / Minute (Gpm)	0.0631	Liters / Second (l/s)
Length	Feet (Ft)	0.3048	Meters (m)
	Inches (In)	25.4	Millimeters (mm)
Weight	Pounds (Lbs)	0.4538	Kilograms (kg)
Velocity	Feet / Second (Fps)	0.3048	Meters / Second (m/s)
Pressure Drop	Feet of Water (Ft)	2.989	Kilopascals (kPa)
	Pounds / Square In. (Psi)	6.895	Kilopascals (kPa)

TEMPERATURE

To convert degrees Fahrenheit (°F) to degrees Celsius (°C), subtract 32° and multiply by 5/9 or 0.5556.

- *Example:* $(45.0^{\circ}\text{F} - 32^{\circ}) \times 0.5556 = 7.22^{\circ}\text{C}$

To convert a temperature range (i.e., a range of 10°F) from Fahrenheit to Celsius, multiply by 5/9 or 0.5556.

- *Example:* $10.0^{\circ}\text{F range} \times 0.5556 = 5.6^{\circ}\text{C range}$



1401 N. Plano Rd. | Richardson, TX 75081 | Tel: 972.680.9136 | Fax: 972.497.0450
www.krueger-hvac.com | kruegerinfo@krueger-hvac.com