

## 5100HF SERIES

LAMINAR FLOW AIR SUPPLY DEVICE FOR HEPA  
 APPLICATIONS WITH ACCESSORIES

## SUBMITTAL SHEET

### DIMENSIONS

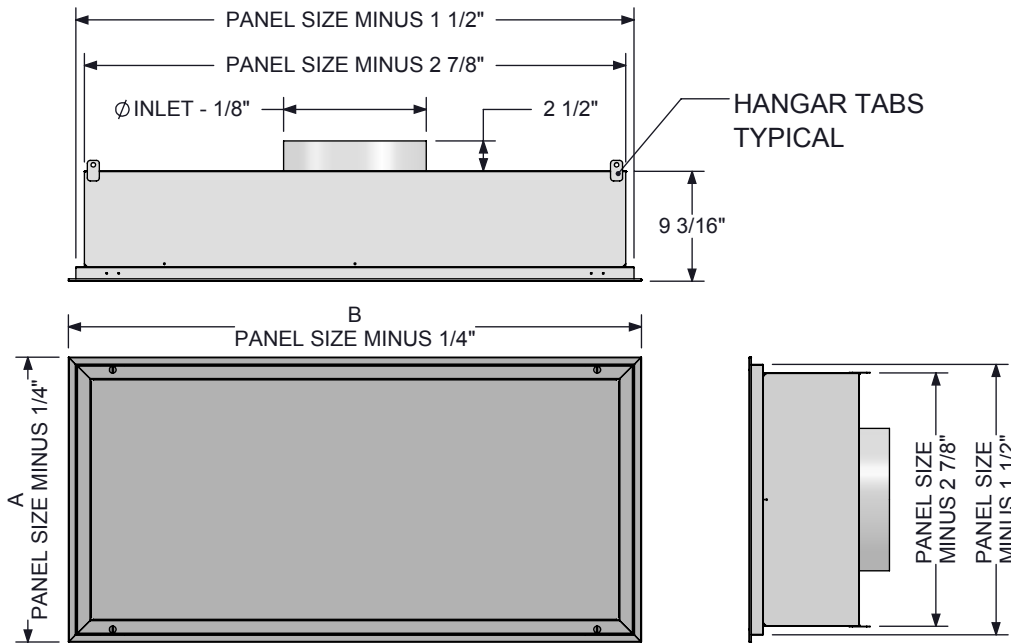

PANEL SIZE	A	B
12 X 24	11.75	23.75
12 X 48	11.75	47.75
12 X 60	11.75	59.75
12 X 72	11.75	71.75
24 X 24	23.75	23.75
24 X 36	23.75	35.75
24 X 48	23.75	47.75
24 X 60	23.75	59.75
24 X 72	23.75	71.75
36 X 48	35.75	47.75
36 X 60	35.75	59.75

### GENERAL DESCRIPTION

- Model 5100HF laminar flow diffuser generates a low velocity, evenly distributed, unidirectional air pattern.
- Introduces clean supply air to the space with minimal entrainment of room air, occurring at the boundaries of the supply air mass of a diffuser or array of diffusers.
- Airtight welded plenum/filter housing construction
- Integral filter rack for use with high efficiency gel seal type filters.
- Trim disc within perforated deflector ring allows minor equalization adjustment and is accessible through the face.
- Static pressure test port.
- Tool-less filter retention system.
- Perforated face is quickly removed by loosening 1/4 turn fasteners.
- Retainer cables prevent accidental dropping of perforated face after removal.
- Designed for surfaced mounted or conventional T-bar ceiling system.
- Compatible with 1" or 1 1/2" T-bar ceiling grids.
- Compatible with 2", 3", and 4" thick filters.
- Filter options include 2" HEPA, 4" HEPA, and 2" ULPA.

### CONFIGURATION OPTIONS

#### Material

- Aluminum Face and Pan
- Aluminum Face and 304 Stainless Steel Pan
- 304 Stainless Steel Face and Pan\*

#### Free Area

- 13% Free Area Perforated Face (Standard Capacity)
- 23% Free Area Perforated Face (Increased Capacity)
- 33% Free Area Perforated Face (Maximum Capacity)

#### Finish

- 01 - Mill Finish
- 44 - British White
- 4A - Anti-Microbial White
- 10 - Alumican

\*316SS AVAILABLE ON REQUEST

### INSULATION OPTIONS

- 1.5" Foil Faced External Insulation
- R6 Molded External Insulation
- Internal Fiber Free Insulation

### ACCESSORY OPTIONS

- Cable Operated Butterfly Damper
- Welded Inlet
- LED Lights\*
- Constant Filter Monitoring
- Aerosol Test System (PAO)
- Differential Pressure Switch / Filter Pressure Indicator Light
- 2" depth HEPA, 99.95% / 4" depth HEPA, 99.95% / 2" depth ULPA, 99.99%

\*ONLY AVAILABLE FOR 24x24, 24x36 24x48 PANELS

## 5100HF SERIES

LAMINAR FLOW AIR SUPPLY DEVICE FOR HEPA  
APPLICATIONS WITH ACCESSORIES

JOB NAME \_\_\_\_\_  
ENGINEER \_\_\_\_\_  
CONTRACTOR \_\_\_\_\_  
TAG \_\_\_\_\_

## SUBMITTAL SHEET

### KNIFE EDGE SEAL DETAIL

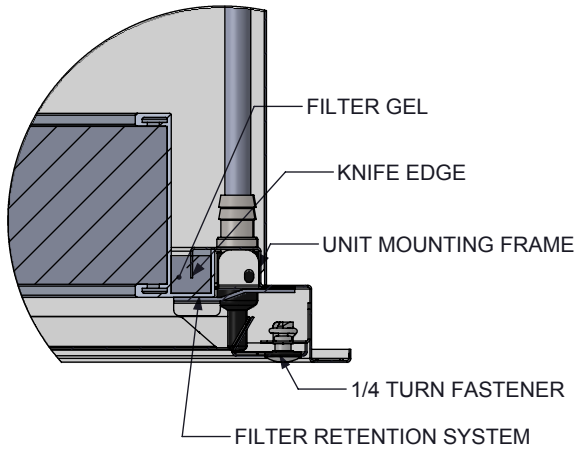

### CONSTANT FILTER MONITORING DETAIL

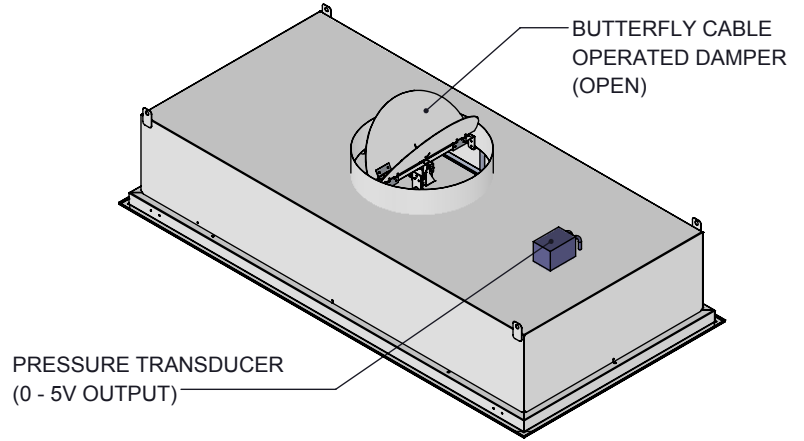

NOTE: REQUIRES 12-30V POWER TO THE UNIT

### CABLE OPERATED DAMPER DETAIL

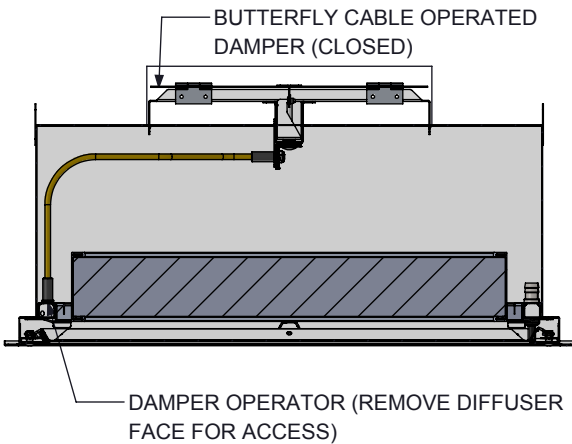

### AEROSOL MANIFOLD AND INJECTION PORT DETAIL

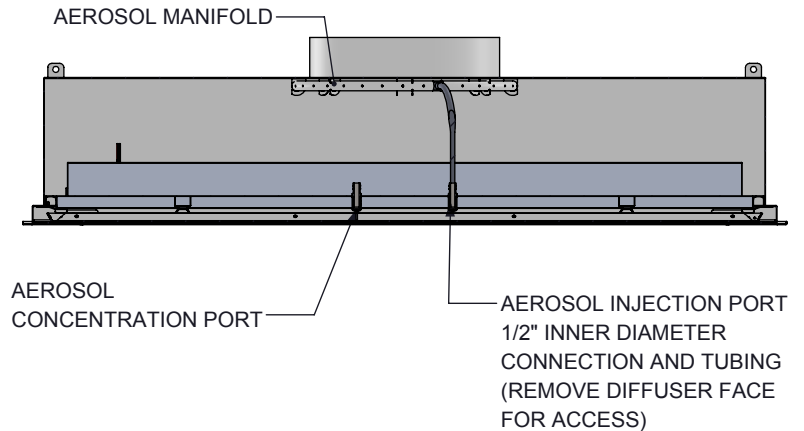

### INDICATOR LIGHTS DETAIL

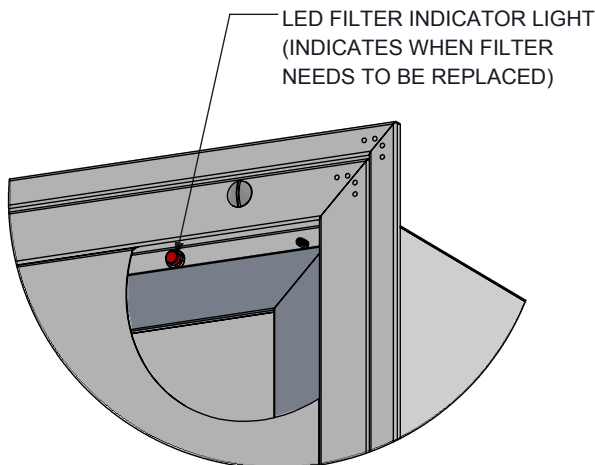

### LED LIGHT DETAIL

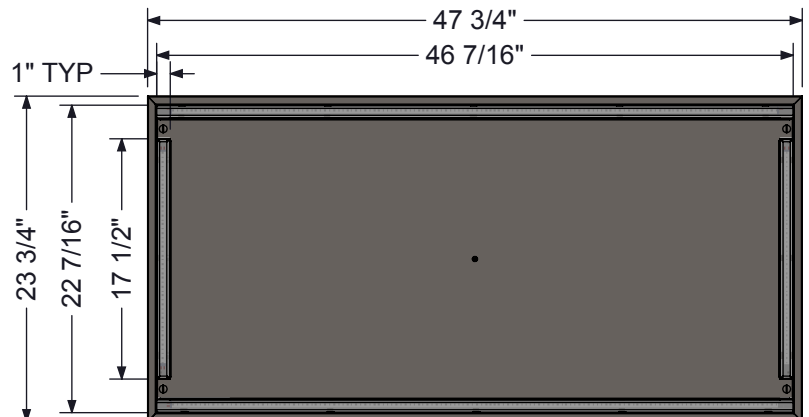

NOTE: 24 X 48 UNIT SHOWN