

## DIMENSIONAL DATA

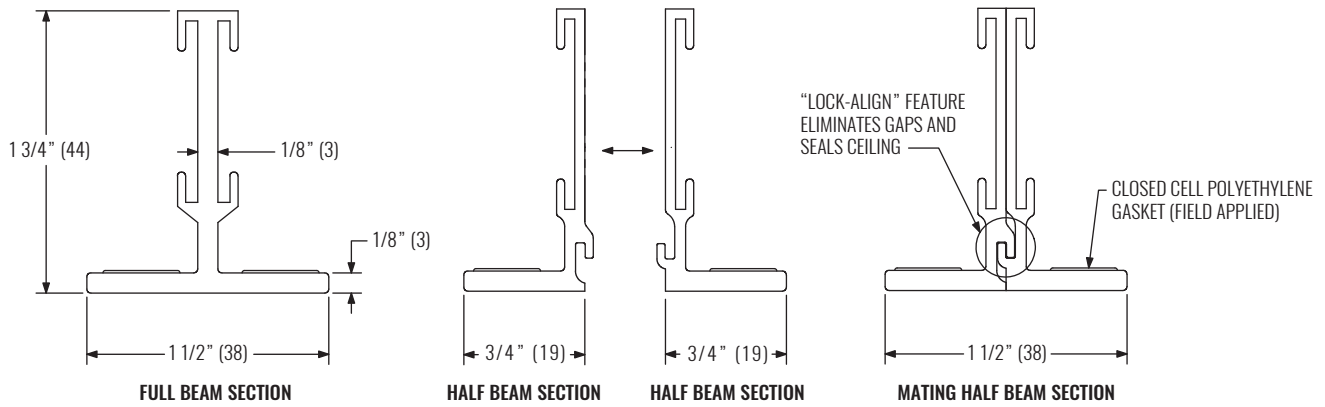

**NOTE:** Dimensions in parentheses are millimeters.

### FULL TEE BEAM FEATURES

- 1 1/2" wide full tee beams exceeding .52 lbs/linear ft
- 1 3/4" high vertical stack head minimizes interference with installed ceiling components and hanger wire or threaded rod
- Minimum wall thickness of 1/8"

### HALF TEE BEAM FEATURES

- 3/4" half tee beams with "Lock-Align" design for positive alignment between mating sections
- Pairs of half tee beams mate together to form a dimensional equivalent of a full tee beam
- Field attached with half tee beam clamps (included)

## EXAMPLE LAYOUT

