

KVFS

KVFF

KVFH



INSTALLATION GUIDE

Installation, Assembly, Start-up, and Service Instructions

TABLE OF CONTENTS

General Safety Guidelines & Safety Symbols	4
Section 1: Receipt and Initial Installation	5
<i>Preface, Unpacking and Inspection</i>	6
<i>Handling and Installation</i>	7
<i>Cooling/Heating Medium Connections</i>	8
<i>Ductwork Connections, Electrical Connections</i>	9
Section 2: Start-up	10
<i>General, Cooling/Heating System, Air System Balancing</i>	10
<i>Water System Balancing, Controls Operation</i>	11
Section 3: Normal Operation and Periodic Maintenance	12
<i>Electric Resistance Heater Assembly</i>	13
<i>Top Panel Removal, Electrical Wiring & Controls, Fan Deck</i>	14
<i>Valves & Piping, Filters - Throwaway, Wall Recessing Panel, Drain</i>	14
<i>Replacement Parts</i>	15
Section 4: Inspection, Installation and Start-up Checklist	16
Section 5: Dimensional Drawings	17

CHANGEABILITY OF THIS DOCUMENT

In complying with Krueger's policy for continuous product improvement, the information contained in this document is subject to change without notice. Krueger makes no commitment to update or provide current information automatically to the manual owner. Updated manuals, if applicable, can be obtained on Krueger's website at www.krueger-hvac.com

Operating/service personnel maintain responsibility for the applicability of these documents to the equipment. If there is any question regarding the applicability of these documents, the technician should verify whether the equipment has been modified and if current literature is available from the owner of the equipment prior to performing any work on the unit.

CHANGE BARS

Revisions made to this document are indicated with a line along the left or right hand column in the area the revision was made. These revisions are to technical information and any other changes in spelling, grammar, or formatting are not included.

IMPORTANT!

READ BEFORE PROCEEDING!

GENERAL SAFETY CONSIDERATIONS

The equipment covered by this manual is designed for safe and reliable operation when installed and operated within its design specification limits. To avoid personal injury or damage to equipment or property while installing or operating this equipment, it is essential that qualified, experienced personnel perform these functions using good judgment and safe practices. See the following cautionary statements.

SAFETY SYMBOLS

The following symbols are used in this document to alert the reader to specific situations:



DANGER - DANGER indicates an imminently hazardous situation which, if not avoided, will result in death or serious injury.



CAUTION - CAUTION identifies a hazard which could lead to damage to the machine, damage to other equipment and/or environmental pollution. Usually an instruction will be given, together with a brief explanation.



WARNING - WARNING indicates a potentially hazardous situation which, if not avoided, could result in death or serious injury.



NOTE - NOTE is used to highlight additional information which may be helpful to you.



DANGER - ELECTRICAL SHOCK HAZARDS. All power must be disconnected prior to installation and servicing this equipment. More than one source of power may be present. Disconnect all power sources to avoid electrocution or shock injuries.

DANGER - MOVING PARTS HAZARDS. Motor and Blower must be disconnected prior to opening access panels. Motors can start automatically, disconnect all power and control circuits prior to servicing to avoid serious crushing or dismemberment injuries.

DANGER - HOT PARTS HAZARD. Electric Resistance heating elements must be disconnected prior to servicing. Electric Heaters may start automatically, disconnect all power and control circuits prior to servicing to avoid burns.



WARNING - Check that the unit assembly and component weights can be safely supported by rigging and lifting equipment.

WARNING - All assemblies must be adequately secured during lifting and rigging by temporary supports and restraints until equipment is permanently fastened and set in its final location.

WARNING - All unit temporary and permanent supports must be capable of safely supporting the equipment's weight and any additional live or dead loads that may be encountered. All supports must be designed to meet applicable local codes and ordinances

WARNING - All fastening devices must be designed to mechanically lock the assembly in place without the capability of loosening or breaking away due to system operation and vibration.



CAUTION - Secure all dampers when servicing damper, actuator or linkages. Dampers may activate automatically, disconnect control circuits or pneumatic control systems to avoid injury.

CAUTION - Protect adjacent flammable materials when brazing. Use flame and heat protection barriers where needed. Have fire extinguisher available and ready for immediate use.

SECTION 1 - RECEIPT AND INITIAL INSTALLATION

FIGURE 1: KVF SERIES, EXPLODED VIEW

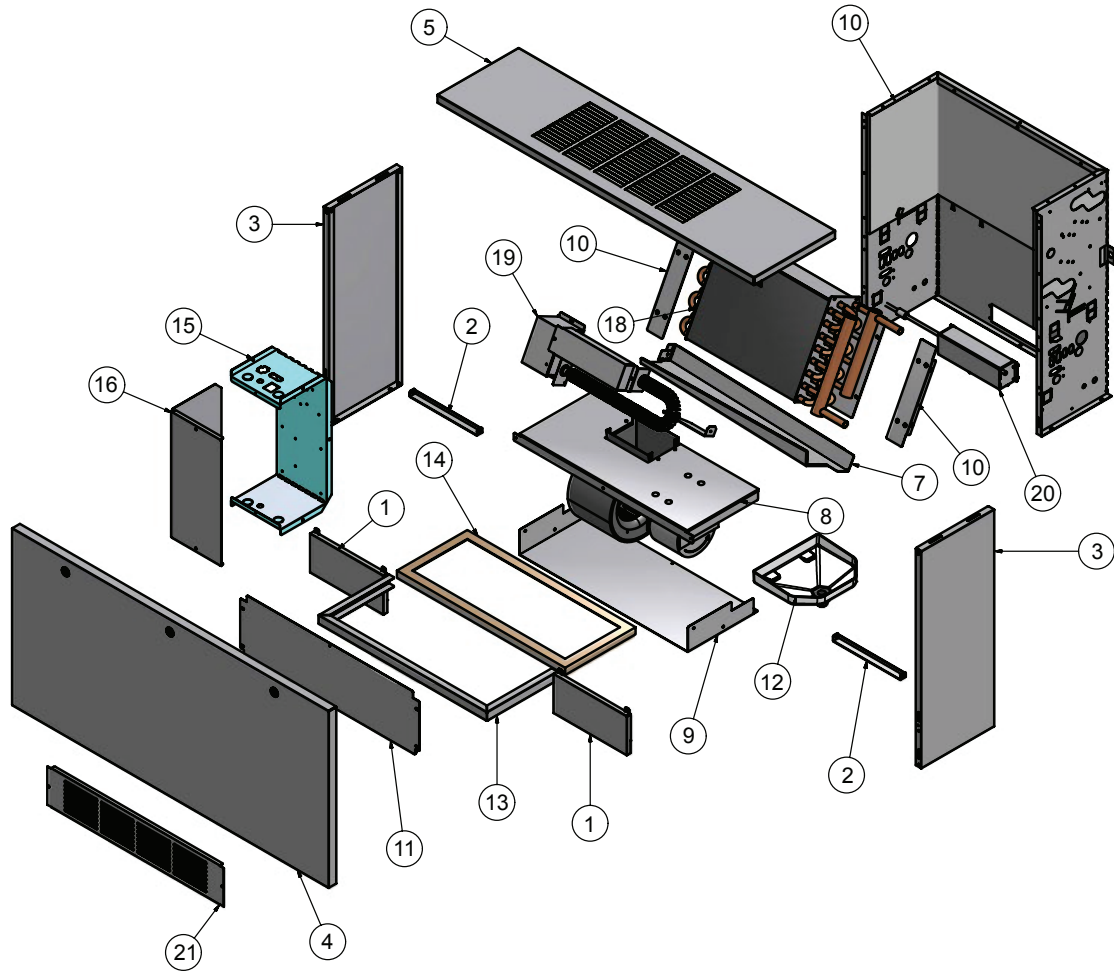

Item	Qty	Title
1	2	Cover, Bottom, Pocket, KVFF/KVFS, Series C
2	2	Support Brace, Bottom, KVFF, Series C
3	2	Panel, Side, External, Series C
4	1	Panel, Front, KVFF/KVFS, Series C
5	1	Panel, Top, KVFF, Series C
6	1	Back Panel, KVF, Series C
7	1	Drip Tray, KVF, Series C
8	1	Assembly, Fan Deck, KVF, Series C
9	1	Panel, Bottom, KVF, Series C
10	2	Bracket, Coil, Mounting, KVF, Series C

Item	Qty	Title
11	1	Panel, Blower Cover, KVF, Series C
12	1	Assembly, Auxiliary Drain Pan
13	1	Rack, Filter, KVFFH, Series C
14	1	Filter
15	1	Control Enclosure
16	1	Control Enclosure Cover
18	1	Assembly, Coil, KVF
19	1	EH Assembly, KVF, Series C
20	1	Assembly, Outside Air, KVF
21	1	Panel, Toe Space, with Slots, KVFS Series C

SECTION 1 - RECEIPT AND INITIAL INSTALLATION

PREFACE

Krueger fan coils represent a prudent investment which can, with proper installation, operation, and regular maintenance, give trouble-free operation and long service.

Your equipment is initially protected under the manufacturer's standard warranty; however, this warranty is provided under the condition that the steps outlined in this manual for initial inspection, proper installation, regular periodic maintenance, and everyday operation of the equipment be followed in detail. This manual should be fully reviewed in advance of any actual work being done on the equipment. Should any questions arise, please contact your local Sales Representative or the factory BEFORE proceeding.

The equipment covered by this manual is available with a vast variety of options and accessories. Consult the approved unit submittal, order acknowledgment, and other manuals for details on the options and accessories provided with the equipment on each project.

The manufacturer assumes no responsibility for personal injury or property damage resulting from improper or unsafe practices during the handling, installation, service, or operation of any equipment.



WARNING - No attempt should be made to handle, install, or service any unit without following safe practices regarding mechanical equipment.



WARNING - Fan coil units are designed for indoor use only. Do not install or store fan coils in an outdoor environment.



WARNING - All power must be disconnected before any installation or service should be attempted. More than one power source may be supplied to a unit. Power to remote mounted control devices may not be supplied through the unit.



WARNING - Never wear bulky or loose fitting clothing when working on any mechanical equipment. Gloves should only be worn when required for proper protection from heat or other possible injury. Safety glasses or goggles should always be worn when drilling, cutting, or working with chemicals such as refrigerants or lubricants.



WARNING - Never pressurize any equipment beyond specified operating pressures. Always pressure test with some inert fluid or gas such as clear water or dry nitrogen to avoid possible damage or injury in the event of a leak or component failure during testing.



WARNING - Always protect adjacent flammable material when welding or soldering. Use suitable heat shield material to contain sparks or drops of solder. Have fire extinguisher available for use when welding or brazing..

UNPACKING & INSPECTION

All units are carefully inspected at the factory throughout the manufacturing process under a strict detailed quality assurance program, and where possible, all major components and subassemblies are carefully tested for proper operation and verified to be in full compliance with the factory manufacturing documents. Customer furnished components such as control valves, switches and DDC controls are not factory tested.

Each unit is carefully packaged for shipment to avoid damage during normal transport and handling. The equipment should always be stored in a dry place in the proper orientation as marked on the carton.

All shipments are made F.O.B. factory and it is the responsibility of the receiving party to inspect the equipment upon arrival. Any obvious damage to the carton and/or its contents should be recorded on the bill of lading and a claim should be filed with the freight carrier.

After determining the condition of the carton exterior, carefully remove each unit from the carton and inspect for hidden damage. At this time check to make sure that "furnished only" items such as switches, thermostats, etc. are accounted for. Any hidden damage should be recorded and immediately reported to the carrier and a claim filed as before. In the event a claim for shipping damage is filed, the unit, shipping carton, and all packing must be retained for physical inspection by the freight carrier.

All equipment should be stored in the factory-shipping carton with internal packing in place until installation.

At the time of receipt, the equipment type and arrangement should be verified against the order documents. Should any discrepancy be found, the local Sales Representative should be notified immediately so that the proper action may be instituted. Should any question arise concerning warranty repairs, the factory must be notified BEFORE any

SECTION 1 - RECEIPT AND INITIAL INSTALLATION

corrective action is taken. Where local repairs or alterations can be accomplished, the factory must be fully informed as to the extent and expected cost of those repairs before work is begun. Where factory operations are required, the factory must be contacted for authorization to return equipment and a Return Authorization Number will be issued. Unauthorized return shipments of equipment and shipments not marked with an authorization number will be refused. In addition, the manufacturer will not accept any claims for unauthorized expenses.

HANDLING & INSTALLATION

While all equipment is designed for durability and fabricated for sturdy construction and may present a rugged appearance, great care must be taken to assure that no force or pressure be applied to the coil, piping or drain stub-outs during handling. Also, depending on the options and accessories, some units could contain delicate components that may be damaged by improper handling. Wherever possible, all units should be maintained in an upright position and handled by the chassis as close as possible to the mounting point locations.

In the case of a full cabinet unit, the unit must obviously be handled by the exterior casing. This is acceptable providing the unit is again maintained in an upright position and no impact forces are applied that may damage internal components or painted surfaces. The equipment covered in this manual IS NOT suitable for outdoor installations. The equipment should never be stored or installed where it may be subjected to a hostile environment such as rain, snow, or extreme temperatures.

During and after installation, special care must be taken to prevent foreign material such as paint, plaster, and drywall dust from being deposited in the drain pan or on the motor or blower wheels. Failure to do so may have serious adverse effects on unit operation and in the case of the motor and blower assembly, may result in immediate or premature failure. All manufacturers' warranties are void if foreign material is deposited on the motor or blower wheels of any unit. Some units and/or job conditions may require some form of temporary covering during construction.

While the manufacturer does not become involved in the design and selection of support methods and components, it should be noted that unacceptable system operating characteristics and/or performance may result from improper or inadequate unit structural support. In addition, adequate clearance must be provided for service and removal of the equipment and its accessory components. Anchoring the equipment in place is accomplished by using the mounting points provided and positioning the unit to maintain the unit on a LEVEL plane. The drain pan

is internally sloped toward the outlet connection. Care must be taken to insure that the unit drain pan does not slope away from the outlet connection.



NOTE - The unit's drain pan is factory sloped toward the drain connection when the unit is installed level and plumb.

Vertical units are designed to be floor mounted or otherwise supported from below and bolted to the wall structure through the mounting holes provide in the chassis. Vertical concealed units are designed to be floor mounted or otherwise supported from below and may be anchored directly through the cabinet back. Units with leveling legs must be anchored through the cabinet back.

If equipped with optional leveling legs, the legs can be adjusted with a wrench before anchoring the unit in place.

The type of mounting device is a matter of choice, however the mounting point should always be that provided in the chassis, or cabinet. Refer to the unit product drawing for mounting hole location and sizes. See pages 17, 18 or 19.

If equipped with optional falseback spacers or sub-bases, these accessories must first be assembled and mounted to the unit before anchoring.

After mounting the unit, it is then ready for the various service connections such as water, drain and electrical. At this time it should be verified that the proper types of service are actually provided to the unit.

On those units requiring chilled water and/or hot water, the proper line size and water temperature should be available to the unit. In the case of refrigerant cooling, the proper line size and refrigerant type should be available at the unit. The auxiliary drain pan is shipped loose for field installation. See the Auxiliary Drain Pan Installation instructions (next page). On units with steam heating coils, the proper line sizing and routing should be verified and the maximum steam pressure applied to the unit should never exceed 15 psig. The drain piping and steam trap should be sized and routed to allow for proper condensate flow. The electrical service to the unit should be compared to the unit nameplate to verify compatibility. The routing and sizing of all piping, and the type and sizing of all wiring and other electrical components such as circuit breakers, disconnect switches, etc. should be determined by the individual job requirements and should not be based on the size and/or type of connection provided on the equipment. All installations should be made in compliance with all governing codes and ordinances. Compliance with all codes is the responsibility of the installing contractor.

SECTION 1 - RECEIPT AND INITIAL INSTALLATION

COOLING/HEATING MEDIUM CONNECTIONS



CAUTION - Toxic residues and loose particles resulting from manufacturing and field piping techniques such as joint compounds, soldering flux, and metal shavings may be present in the unit and the piping system. Special consideration must be given to system cleanliness when connecting to solar, domestic or potable water systems.

Submittals and Product Catalogs detailing unit operation, controls, and connections should be thoroughly reviewed BEFORE beginning the connection of the various cooling and/or heating mediums to the unit.

All accessory valve packages should be installed as required, and all service valves should be checked for proper operation.

If coil and valve package connections are to be made with “sweat” or solder joint, care should be taken to assure that no components in the valve package are subjected to a high temperature which may damage seals or other materials. Many two-position electric control valves, depending on valve operation, are provided with a manual-opening lever. This lever should be placed in the “open” position during all soldering or brazing operations. Valve bodies should be wrapped with a wet rag to help dissipate heat encountered during brazing.

If the valve package connection at the coil is made with a union, the coil side of the union must be prevented from twisting (“backed up”) during tightening to prevent damage to the coil tubing. Over-tightening must be avoided to prevent distorting the union seal surface and destroying the union.

In the case of field installed valves and piping, the chilled water valve cluster (or expansion valve on DX units) should be installed in such a way that any dripping or sweating is contained in the auxiliary drain pan or other device.

In the case of factory mounted piping packages, it is important to verify that all unions are tight, since shipping and handling may cause loosening.

After the connections are completed, the system should then be tested for leaks. Since some components are not designed to hold pressure with a gas, hydronic systems should be tested with water.

FIGURE 2: AUXILIARY DRAIN PAN INSTALLATION

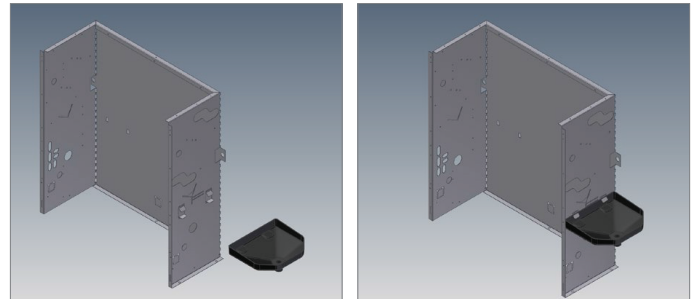

Auxiliary Drain Pan Installation Details

1. Bend lower support tabs down 90°.
2. Bend upper support tabs up 90°.
3. Position drain pan in place and then bend upper support tabs down until pan is secure.
4. Bend float switch mount out 90° if needed.
5. Standard pan shown; typical for extended pan.

NOTE: Installing contractor must ensure that the connected drain piping maintains the proper pan orientation.



CAUTION - All water coils must be protected from freezing after initial filling with water. Even if the system is drained, unit coils may still hold enough water to cause damage when exposed to temperatures below freezing.

Refrigerant systems should be tested with dry nitrogen rather than air to prevent the introduction of moisture into the system. In the event that leaking or defective components are discovered, the Sales Representative must be notified BEFORE any repairs are attempted. All leaks should be repaired before proceeding with the installation.

After system integrity has been established the piping should be insulated in accordance with the project specifications. ALL chilled water piping and valves or refrigerant suction piping not located over drain pans must be insulated to prevent damage from sweating. This includes factory and field piping inside the unit cabinet.

The drain should always be connected and piped to an acceptable disposal point. For proper moisture carry-off, the drain piping should be sloped away from the unit at least 1/8” per foot. A drain trap may be required by local codes and it is strongly recommended for odor containment.

SECTION 1 - RECEIPT AND INITIAL INSTALLATION

DUCTWORK CONNECTIONS

All ductwork and/or supply and return grilles should be installed in accordance with the project plans and specifications. If not included on the unit or furnished from the factory, supply and return grilles should be provided as recommended in the product catalog.

All units must be installed in non-combustible areas.

Some models are designed to be connected to ductwork with a MINIMUM amount of external static pressure. These units may be damaged by operation without the proper ductwork connected. Consult the approved submittals and the product catalog for unit external static pressure limitations.

Units provided with outside air for ventilation should have some form of low temperature protection to prevent coil freeze-up.

It should be noted that none of these methods would adequately protect a coil in the event of power failure. The safest method of freeze protection is to use glycol in the proper percent solution for the coldest expected air temperature.

The manufacturer assumes no responsibility for undesirable system operation due to improper design, equipment or component selection, and/or installation of ductwork, grilles, and other field supplied components.

ELECTRICAL CONNECTIONS

The unit nameplate lists the unit electrical characteristics such as the required supply voltage, fan and heater amperage and required circuit ampacities. The unit wiring diagram shows all unit and field wiring. Since each project is different and each unit on a project may be different, the installer must be familiar with the wiring diagram and nameplate on the unit BEFORE beginning any wiring. All components furnished for field installation, by either the factory or the controls contractor should be located and checked for proper function and compatibility. All internal components should be checked for shipping damage and all electrical connections should be tightened to minimize problems during start-up.

Any devices such as fan switches or thermostats that have been furnished from the factory for field installation must be wired in strict accordance with the applicable wiring diagrams. Failure to do so could result in personal injury or damage to components and will void all manufacturers' warranties.

The fan motor(s) should never be controlled by any wiring or device other than the factory furnished switch, thermostat/switch combination, without factory authorization.

All field wiring should be done in accordance with governing codes and ordinances. Any modification of the unit wiring without factory authorization will result in voiding of all factory warranties and will nullify any agency listings.

The manufacturer assumes no responsibility for any damages and/or injuries resulting from improperly field installed or wired components.

Fan speed can be varied with optional SCR. SCR is shipped wired to high speed tap only. Wiring to medium or low taps could cause excessive vibration, noise and overheating which can lead to motor failure.

FIGURE 3: ELECTRICAL CONNECTIONS

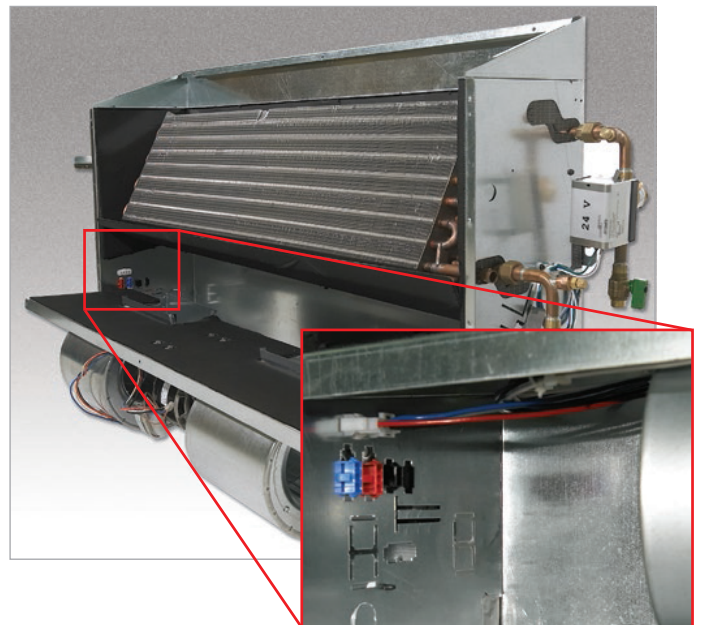

ELECTRICAL QUICK CONNECT

KVF units allow for a single technician to service the fan/motor by keeping the fan deck less than 44". Motors are supplied with quick connectors to allow electrical service without the need for tools.

SECTION 2 - START-UP

GENERAL

Before beginning any start-up operation, the startup personnel should familiarize themselves with the unit, options and accessories, and control sequence to understand the proper system operation. All personnel should have a good working knowledge of general start-up procedures and have the appropriate start-up and balancing guides available for consultation.

The initial step in any startup operation should be a final visual inspection. All equipment, plenums, duct-work, and piping should be inspected to verify that all systems are complete and properly installed and mounted, and that no debris or foreign articles such as paper or drink cans are left in the units or other areas. Each unit should be checked for loose wires, free blower wheel operation, and loose or missing access panels or doors. Except as required during start-up and balancing operations, no fan coil units should be operated without all the proper ductwork attached, supply and return grilles in place, and all access doors and panels in place and secure. A clean filter of the proper size and type must also be installed. Failure to do so could result in damage to the equipment or building and furnishings, and/or void all manufacturers' warranties.

COOLING/HEATING SYSTEM

Prior to the water system start-up and balancing, the chilled/hot water systems should be flushed to clean out dirt and debris, which may have collected in the piping during construction. During this procedure, all unit service valves must be in the closed position. This prevents foreign matter from entering the unit and clogging the valves and metering devices. Strainers should be installed in the piping mains to prevent this material from entering the units during normal operation.

During system filling, air venting from the unit is accomplished by the use of the standard, manual or optional automatic air vent fitting installed on the coil. In the case of the manual air vent fitting, the screw should be turned counterclockwise no more than 1-1/2 turns to operate the air vent. Automatic air vents may be unscrewed one turn counterclockwise to speed initial venting but should be screwed in for automatic venting after start-up operations.



CAUTION - Make sure units are properly wired prior to unit startup.



CAUTION - Do not operate unit without panels fully installed.



CAUTION - Fan coil units are not intended for use as temporary heat/cool or ventilation during building construction. The units are not designed or equipped to operate in a dusty environment. Fan wheels can become coated with construction dust, resulting in an unbalanced wheel. This can in turn contribute to reduced motor life. Inlet filters cannot provide adequate protection as they will quickly become clogged. Failure to operate the unit in the condition outlined above could result in damage to the equipment or building and furnishings, and/or void all manufacturer's warranties.



CAUTION - The air vent provided on the unit is not intended to replace the main system air vents and may not release air trapped in other parts of the system. Inspect the entire system for potential air traps and vent those areas as required, independently. In addition, some systems may require repeat venting over a period of time to properly eliminate air from the system.



CAUTION - Do not allow supply or return air grilles to be blocked.

AIR SYSTEM BALANCING

All ductwork must be complete and connected, and all grilles, filters, access doors and panels must be properly installed to establish actual system operating conditions BEFORE beginning air balancing operations.

Each individual unit and attached ductwork is a unique system with its own operating characteristics. For this reason, balance specialists who are familiar with all procedures required to properly establish air distribution and fan system operating conditions normally do air balancing. Unqualified personnel should not attempt these procedures. Exposed units with no ductwork do not require air balancing other than selecting the desired fan speed.

After the proper system operation is established, the actual unit air delivery and the actual fan motor amperage draw for each unit should be recorded in a convenient place for future reference such as the inspection, installation, & start-up check sheet, a copy of which is provided at the back of this manual. Contact the Sales Representative or the factory for additional copies of this sheet.

SECTION 2 - START-UP

WATER SYSTEM BALANCING

A complete knowledge of the hydronic system, its components, and controls is essential to proper water system balancing and this procedure should not be attempted by unqualified personnel. The system must be complete and all components must be in operating condition BEFORE beginning water system balancing operations.

Each hydronic system has different operating characteristics depending on the devices and controls in the system. The actual balancing technique may vary from one system to another.

After the proper system operation is established, the appropriate system operating conditions such as various water temperatures and flow rates should be recorded in a convenient place for future reference such as the inspection, installation, and start-up check sheet, a copy of which is provided on the back of this manual. Contact the Sales Representative or the factory for additional copies of this sheet.

Before and during water system balancing, conditions may exist which can result in noticeable water noise or undesired valve operation due to incorrect system pressures. After the entire system is balanced, these conditions will not exist on properly designed systems.

MOTOR & FAN DATA - 3-ROW COIL, NO HEAT, NO TOE KICK, STANDARD THROW AWAY PANEL FILTER

Unit Size	Fan Speed	Motor HP (Qty)	Number of Fans	115 Volts		208-230 Volts		277 Volts	
				FLA	WATTS	FLA	WATTS	FLA	WATTS
02	High	(1) 1/50	1	0.40	45	0.27	53	0.21	57
	Medium				35		41		44
	Low				28		36		40
03	High	(1) 1/20	1	0.60	60	0.40	67	0.31	73
	Medium				48		54		60
	Low				43		49		54
04	High	(1) 1/20	2	0.75	70	0.39	71	0.35	76
	Medium				61		60		65
	Low				58		52		58
06	High	(1) 1/20	2	0.75	80	0.39	81	0.35	87
	Medium				74		71		77
	Low				61		59		64
08	High	(1) 1/10	2	1.10	114	0.51	109	0.46	114
	Medium				81		77		80
	Low				71		66		70
10	High	(2) 1/20	4	1.50	132	0.78	140	0.70	144
	Medium				114		116		120
	Low				107		101		106
12	High	(2) 1/20	4	1.50	142	0.78	147	0.70	154
	Medium				126		125		131
	Low				114		107		114

NOTES: Based on KVFF, exposed cabinet model. Fan watts shown at operating conditions. Data was taken without ductwork. Unit size 04, 06, 08, 10 and 12 data generated at 115V, 230V and 277V. Unit size 02 and 03 data generated with 115V, 240V to 120V transformer (230V line voltage) and 277V to 120V transformer (277V line voltage). FLA based on motor nameplate. For FLA use unit voltage, and size at high speed.

CONTROLS OPERATION

Before proper control operation can be verified all other systems must be in proper operation. The correct water and air temperatures must be present for the control function being tested. Some controls and features are designed to not operate under certain conditions.

A wide range of controls and electrical options and accessories may be used with the equipment covered in this manual. Consult the approved unit submittals, order acknowledgment, and other manuals for detailed information regarding each individual unit and its controls. Since controls and features may vary from one unit to another, care should be taken to identify the controls to be used on each unit and their proper control sequence. Information provided by component manufacturers regarding installation, operation, and maintenance of their individual controls is available upon request.

SECTION 3 - NORMAL OPERATION & PERIODIC MAINTENANCE

GENERAL

Each unit on a job will have its own unique operating environment and conditions that may dictate a maintenance schedule for that unit that is different from other equipment on the job. A formal schedule of regular maintenance and an individual unit log should be established and maintained. This will help to achieve the maximum performance and service life of each unit on the job.



NOTE - Information regarding safety precautions contained in the preface at the beginning of this manual should be followed during any service and maintenance operations.

For more detailed information concerning service operations, consult your Sales Representative or the Factory.

The type of fan operation is determined by the control components and their method of wiring, and may vary from unit to unit. Refer to the wiring diagram for each unit for that unit's individual operating characteristics. Motors are permanently lubricated, PSC type and do not require field lubrication.

Should the assembly require more extensive service, the motor/blower assembly may be removed from the unit to facilitate such operations as motor or blower wheel/housing replacement, etc. Dirt and dust should not be allowed to accumulate on the blower wheel or housing. This can result in an unbalanced blower wheel condition that can damage a blower wheel or motor. The wheel and housing may be cleaned periodically using a vacuum cleaner and a brush taking care not to dislodge the factory balancing weights on the blower wheel blades.

FIGURE 4: MOTOR/BLOWER ASSEMBLY

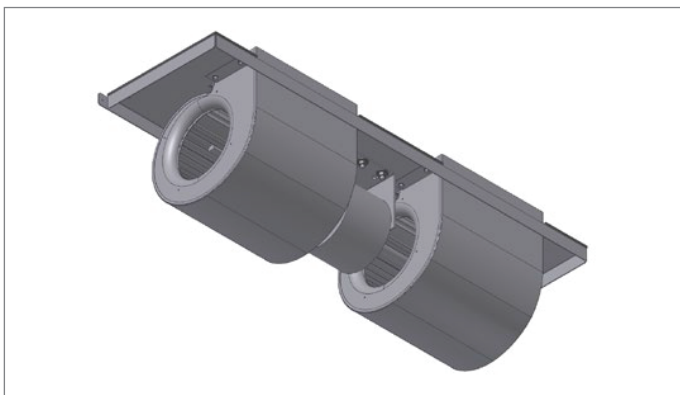

Motor/blower assembly can be removed by pulling two screws from the frame. Fan deck designed to not exceed 44".

FIGURE 5: COIL

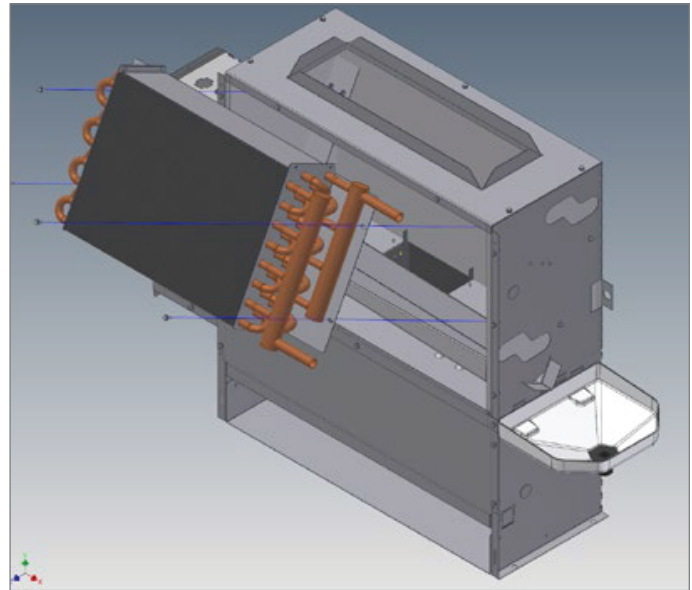

Coils may be cleaned in place by removing the motor/blower assemblies and brushing the entering air face between fins with a stiff brush. Cleaning with a vacuum cleaner should follow brushing. If a compressed air source is available, the coil may also be cleaned by blowing air through the coil fins from the leaving air face. Vacuuming should again follow this. Units provided with the proper type of air filters, replaced regularly, will require coil cleaning.

FIGURE 6: ELECTRICAL ACCESS

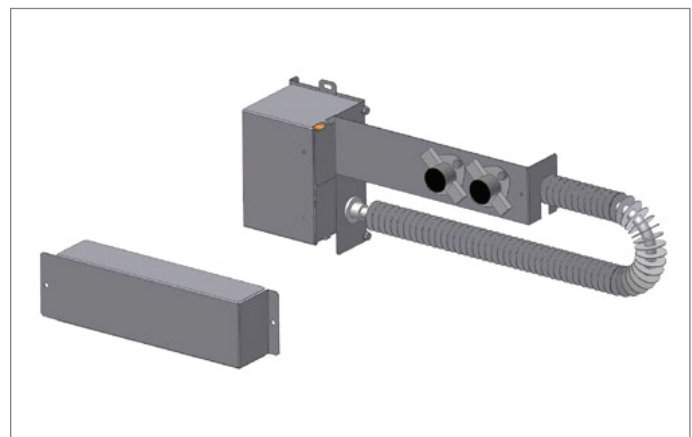

To access electrical limits, remove protective cover.

SECTION 3 - NORMAL OPERATION & PERIODIC MAINTENANCE

ELECTRIC RESISTANCE HEATER ASSEMBLY

Electric resistance heaters typically require no normal periodic maintenance when unit air filters are changed properly. Other conditions and equipment may affect the operation and service life in the system. The two most important operating conditions for an electric heater are proper airflow and proper supply voltage. High supply voltage and/or poorly distributed or insufficient airflow over the element will result in element overheating. This condition may result in the heater cycling on the high limit thermal cutout.

Sheathed type heaters provided have an automatic reset switch with a back-up high limit thermal switch. Automatic reset switches are as the name implies; they reset automatically after the heater has cooled down. High limit thermal switches must be replaced once the circuit has been broken. The high limit thermal cutout device is a safety device only and is not intended for continuous operation. With proper unit application and during normal operation, the high limit thermal cutout will not operate. This device only operates when some problem exists and ANY condition that causes high limit cutout MUST be corrected immediately. High supply voltage also causes excessive amperage draw and may result in tripping of the circuit breaker or blowing of the fuses on the incoming power supply.

ELECTRIC HEAT SELECTION CHART

UNIT SIZE	MBH	3.4	5.1	6.8	10.2	13.7	17.1	20.5
	kW	1.0	1.5	2.0	3.0	4.0	5.0	6.0
	VOLTS	AMPS						
02	115	8.3	-	-	-	-	-	-
	208	4.8	-	-	-	-	-	-
	230	4.2	-	-	-	-	-	-
	277	3.6	-	-	-	-	-	-
03	115	8.3	12.5	-	-	-	-	-
	208	4.8	7.2	-	-	-	-	-
	230	4.2	6.3	-	-	-	-	-
	277	3.6	5.4	-	-	-	-	-
04	115	8.3	12.5	16.7	-	-	-	-
	208	4.8	7.2	9.6	-	-	-	-
	230	4.2	6.3	8.3	-	-	-	-
	277	3.6	5.4	7.2	-	-	-	-
06	115	8.3	12.5	16.7	25.0	-	-	-
	208	4.8	7.2	9.6	14.4	-	-	-
	230	4.2	6.3	8.3	12.5	-	-	-
	277	3.6	5.4	7.2	10.8	-	-	-
08	115	8.3	12.5	16.7	25.0	-	-	-
	208	4.8	7.2	9.6	14.4	19.2	-	-
	230	4.2	6.3	8.3	12.5	16.7	-	-
	277	3.6	5.4	7.2	10.8	14.4	-	-
10	115	8.3	12.5	16.7	25.0	-	-	-
	208	4.8	7.2	9.6	14.4	19.2	24.0	-
	230	4.2	6.3	8.3	12.5	16.7	20.8	-
	277	3.6	5.4	7.2	10.8	14.4	18.1	-
12	115	8.3	12.5	16.7	25.0	-	-	-
	208	4.8	7.2	9.6	14.4	19.2	24.0	28.9
	230	4.2	6.3	8.3	12.5	16.7	20.8	25.0
	277	3.6	5.4	7.2	10.8	14.4	18.1	21.7

NOTES: Shaded areas of the electric heat selection chart indicate kW and voltage options not available. Available voltages are single phase, 60 hertz. Size heater for Leaving Air Temperature (LAT) less than 104°F. Silent, solid state heater relay is available for heater currents less than 18 amps. Ask your local Krueger Representative about continuously modulating electric heat using SSR and special control options.

SECTION 3 - NORMAL OPERATION & PERIODIC MAINTENANCE

TOP PANEL REMOVAL (KVFS, KVFF)

Depending on options and unit size, the top panel may need to be removed to service or replace fan coil components. Top panel removal does not require the unit to be pulled away from wall, or for piping/electrical connections to be broken. Top panel is screwed onto unit through front-accessible screws. Pull screws and lift panel to remove.

FIGURE 7: TOP PANEL REMOVAL

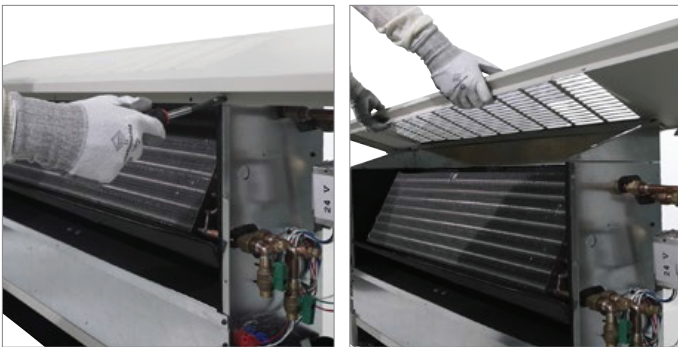

ELECTRICAL WIRING & CONTROLS

The electrical operation of each unit is determined by the components and wiring of the unit and may vary from unit to unit. Consult the wiring diagram for the actual type and number of controls provided on each unit. The integrity of all electrical connections should be verified at least twice during the first year of operation. Afterwards, all controls should be inspected regularly for proper operation. Some components may experience erratic operation or failure due to age. Wall thermostats may also become clogged with dust and lint and should be periodically inspected and cleaned to provide reliable operation.

When replacing any components such as fuses, contactors, or relays, use only the exact type, size, and voltage component as furnished from the factory. Any deviation without factory authorization could result in personnel injury or damage to the unit and will void all factory warranties. All repair work should be done in such a manner as to maintain the equipment in compliance with governing codes and ordinances or testing agency listings.

More specific information regarding the use and operating characteristics of the standard controls offered by this manufacturer is contained in other manuals.

FAN DECK

The fan/drain pan assembly is easily removable for service access to motors and blowers at, or away from, the unit.

VALVES & PIPING

No formal maintenance is required on the valve package components most commonly used with fan coil units other than a visual inspection for possible leaks in the course of other normal periodic maintenance. In the event that a valve should need replacement, the same precautions taken during the initial installation to protect the valve package from excessive heat should also be used during replacement.

FILTERS, THROWAWAY

The type of throwaway filter most commonly used on fan coil units should be replaced on a regular basis. The time interval between each replacement should be established based on regular inspection of the filter and should be recorded in the log for each unit. Refer to the product catalog for the recommended filter size for each product type and size. If the replacement filters are not purchased from the factory, the filters used should be the same type and size as that furnished from or recommended by the factory. Consult the factory for applications using filter types other than the factory standard or optional product.

Filters are installed in a full metal u-carriage steel filter rack. The filter rack is designed to slide in and out of the unit without the need for tools. To replace filter: slide filter rack out of the front, pull filters from metal frame, insert new filters into metal frame and insert filters and frame into unit. Ensure that filter frame is completely reinstalled into the unit to prevent unfiltered air bypass or warping of filters.

WALL RECESSING PANEL

A wall panel is supplied to allow access to concealed fan coils. Perimeter frame must be permanently fastened to wall or other structure capable of supporting it. Panel is designed for installation and removal from perimeter frame by 1/4 turn fasteners. On panels with supply and return air, it is critical that unit presses against insulation on panel. Failure to properly space unit and panel could result in air bypass and improper conditioning of space.

DRAIN

The drain should be checked before initial start-up and at the beginning of each cooling season to assure that the lines are clear. If it is clogged, steps should be taken to clear the debris so that condensate will flow easily.

Periodic checks of the drain should be made during the cooling season to maintain a free flowing condensate. Should the growth of algae and/or bacteria be a concern, consult an air conditioning and refrigeration supply organization familiar with local conditions for chemicals available to control these agents.

SECTION 3 - NORMAL OPERATION & PERIODIC MAINTENANCE

FIGURE 8: FILTER REMOVAL



FIGURE 9: FILTER AND FILTER RACK

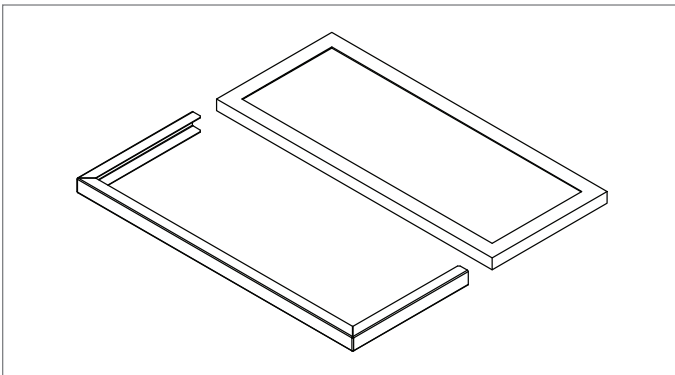
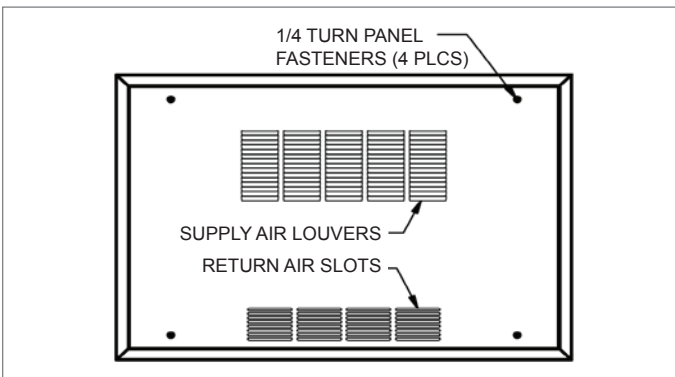

FIGURE 10: WALL RECESSING PANEL



REPLACEMENT PARTS

Factory replacement parts should be used wherever possible to maintain the unit performance and operating characteristics and the testing agency listings. Replacement parts may be purchased through the local Sales Representative.

Contact the local Sales Representative or the factory before attempting any unit modifications. Any modifications not authorized by the factory could result in personnel injury and damage to the unit and could void all factory warranties.

When ordering parts, the following information must be supplied to ensure proper part identification:

1. Complete unit model number.
2. Unit hand connection (right/left hand) while facing into the return air stream.
3. Complete part description including any numbers.

On warranty replacements, in addition to the information previously listed, the project CO # that appears on the unit nameplate, is required. Contact the factory for authorization to return any parts such as defective parts replaced in warranty. All shipments returned to the factory **MUST** be marked with a Return Authorization Number, which is provided by the factory.

All equipment and components sold through the Parts Department are warranted under the same conditions as the standard manufacturer's warranty with the exception that the warranty period is 12 months unless the component is furnished as warranty replacement. Parts furnished as warranty replacements are warranted for the remaining term of the original unit warranties.

SECTION 4 - INSPECTION, INSTALLATION & START-UP CHECKLIST

RECEIVING & INSPECTION

- Unit received undamaged.
- Unit arrangement/hand correct.
- Unit received complete as ordered.
- Unit structural support complete and correct.

HANDLING & INSTALLATION

- Unit mounted level and square.
- Proper electrical service provided.
- Proper service switch/disconnect provided.
- Proper chilled water line size to unit.
- Proper refrigerant line sizes to unit.
- Proper steam condensate trap on return line.
- All services to unit in code compliance.
- Proper access provided for unit and accessories.
- Proper over-current protection provided.
- Proper hot water line to unit.
- Proper steam line sizes to unit.
- Proper steam supply pressure to unit (15psi max).
- All shipping screws and braces removed.

COOLING/HEATING CONNECTIONS

- Protect valve package components from heat.
- Connect field piping to unit.
- Install drain line and traps as required.
- Install condensate pan under piping as required.
- Mount valve packages.
- Pressure test all piping for leaks.
- Insulate all piping as required. If the valve package connection at the coil is made with a union, the coil side of the union must be prevented from twisting ("backed up") during tightening to prevent damage to the coil tubing. Over-tightening must be avoided to prevent distorting the union seal surface and destroying the union.

DUCTWORK CONNECTIONS

- Install ductwork, fittings and grilles as required.
- Control outside air for freeze protection.
- Proper supply and return grille type and size used.
- Insulate all ductwork as required.

ELECTRICAL CONNECTIONS

- Refer to unit wiring diagram.
- All field wiring in code compliance.
- Connect incoming power service or services.

UNIT STARTUP

- General visual unit and system inspection.
- Record ambient temperature.
- Close all unit isolation valves.
- Fill systems with water/refrigerant.
- All ductwork and grilles in place.
- Start fans, etc.
- Check all ductwork and units for air leaks.
- Record all final settings for future use.
- Check all dampers for proper operation.
- Verify proper heating operation.
- Check all piping for leakage.
- Record electrical supply voltage.
- Check all wiring for secure connections.
- Flush water systems.
- Vent water systems as required.
- All unit panels and filters in place.
- Check for overload condition of all units.
- Balance air systems as required.
- Check piping and ductwork for vibration.
- Verify proper cooling operation.
- Reinstall all covers and access panels.

SECTION 5 - DIMENSIONAL DRAWINGS

KVFH TOP AND SIDE VIEWS

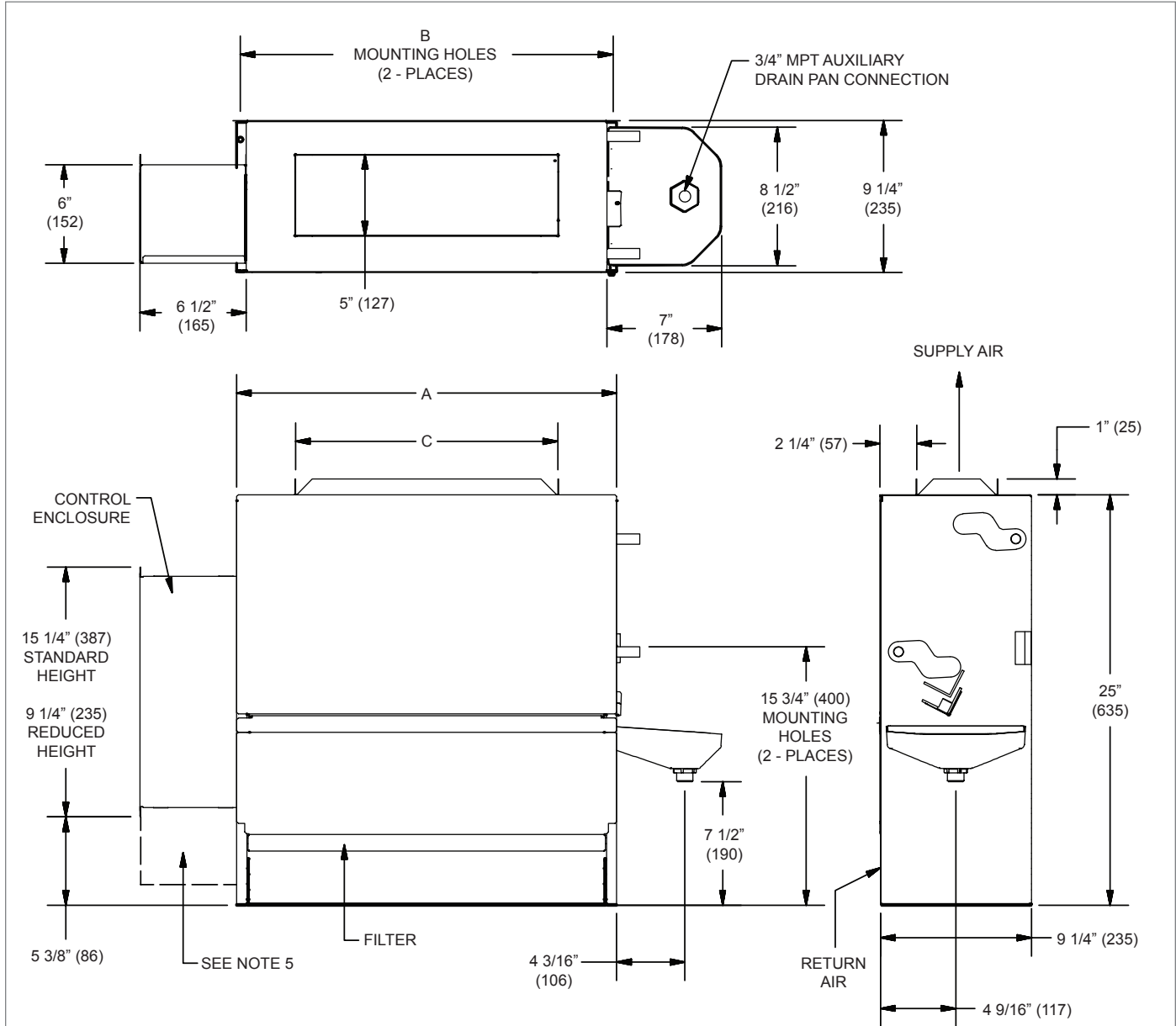

DIMENSIONAL REFERENCES

Unit Size	A	B	C
02	23 3/16" (589)	22 3/4" (578)	16" (406)
03	27 3/16" (691)	26 3/4" (679)	20" (508)
04	33 3/16" (843)	32 3/4" (832)	26" (660)
06	43 3/16" (1097)	42 3/4" (1086)	36" (914)
08	45 3/16" (1148)	44 3/4" (1137)	38" (965)
10	59 3/16" (1503)	58 3/4" (1492)	52" (1320)
12	67 3/16" (1707)	66 3/4" (1695)	60" (1524)

NOTES: All dimensions are in inches (millimeters) and are +/- 1/4" (6mm). Junction box size and location varies with unit features. Control options may be limited. Provide sufficient clearance to access electrical controls and comply with applicable codes and ordinances. Reduced height control enclosure is standard with opposite end coils. Right hand coil connection shown. Left hand unit is similar, but opposite. Some piping package options may require extended drain pans. Size 2 and 3 with 208/230VAC or 277VAC have a 3 5/8" (92) extended control enclosure.

SECTION 5 - DIMENSIONAL DRAWINGS

KVFF TOP AND SIDE VIEWS

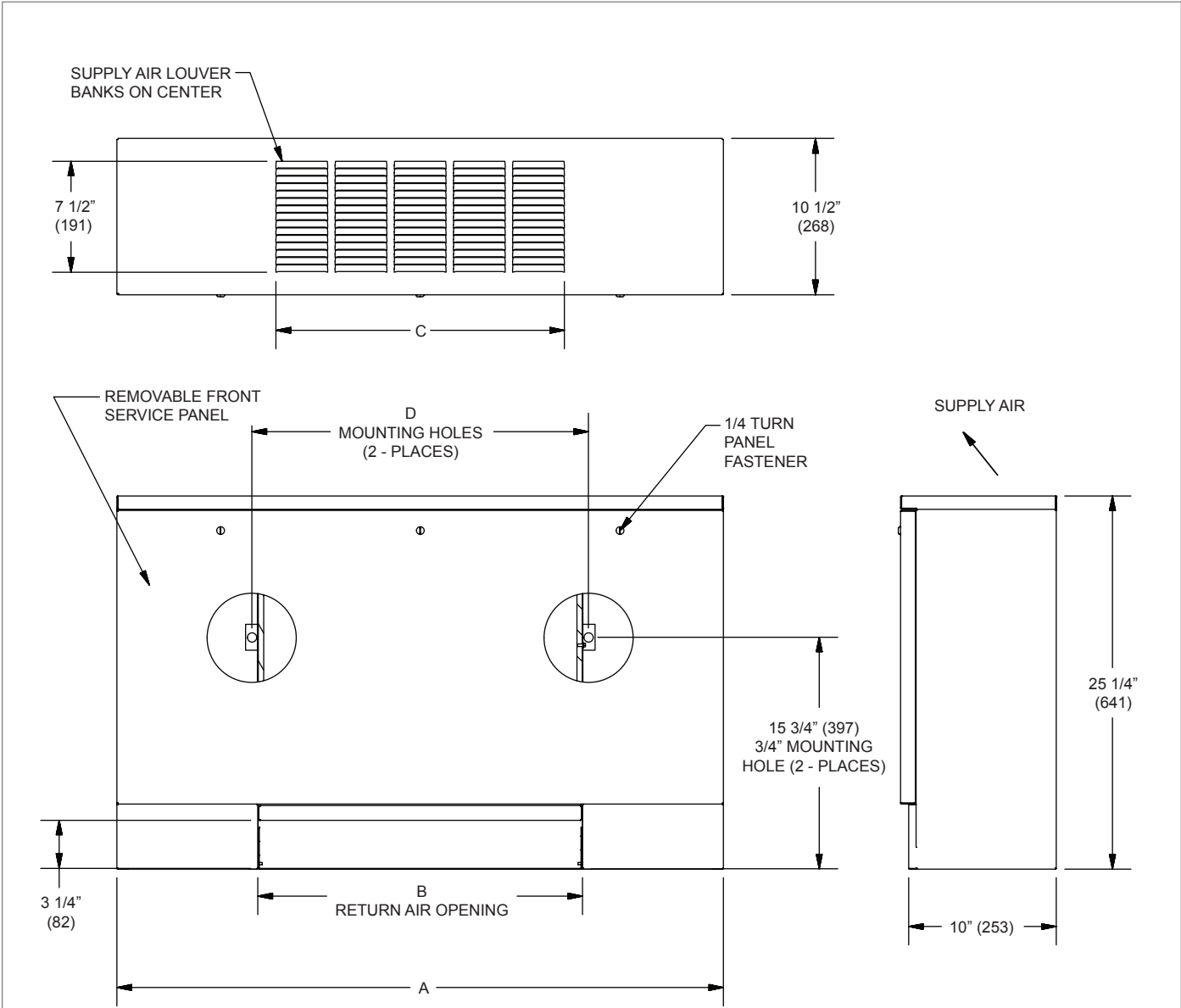

DIMENSIONAL REFERENCES

Unit Size	A	B	C	D
02	40" (1016)	22" (559)	19 1/2" (495)	22 3/4" (578)
03	44" (1117)	26" (660)	23 1/2" (597)	26 3/4" (679)
04	50" (1270)	32" (813)	27 1/2" (699)	32 3/4" (832)
06	60" (1524)	42" (1067)	39 1/2" (1003)	42 3/4" (1086)
08	62" (1574)	44" (1118)	39 1/2" (1003)	44 3/4" (1137)
10	76" (1930)	58" (1473)	55 1/2" (1410)	58 3/4" (1492)
12	84" (2133)	66" (1676)	63 1/2" (1613)	66 3/4" (1695)

NOTES: All dimensions are in inches (millimeters) and are +/- 1/4" (6mm). Junction box size and location varies with unit features. Control options may be limited. Provide sufficient clearance to access electrical controls and comply with applicable codes and ordinances. Standard cabinet finish is "Pearl White Satin". Right hand unit shown, left hand unit similar, but opposite. Parametric design available to increase Height or Width. (See parametric offerings drawing.) Some control or piping package options may require extended end pockets and/or extended drain pans. (See extended end pocket drawing.) False back extension available.

SECTION 5 - DIMENSIONAL DRAWINGS

KVFS TOP AND SIDE VIEWS

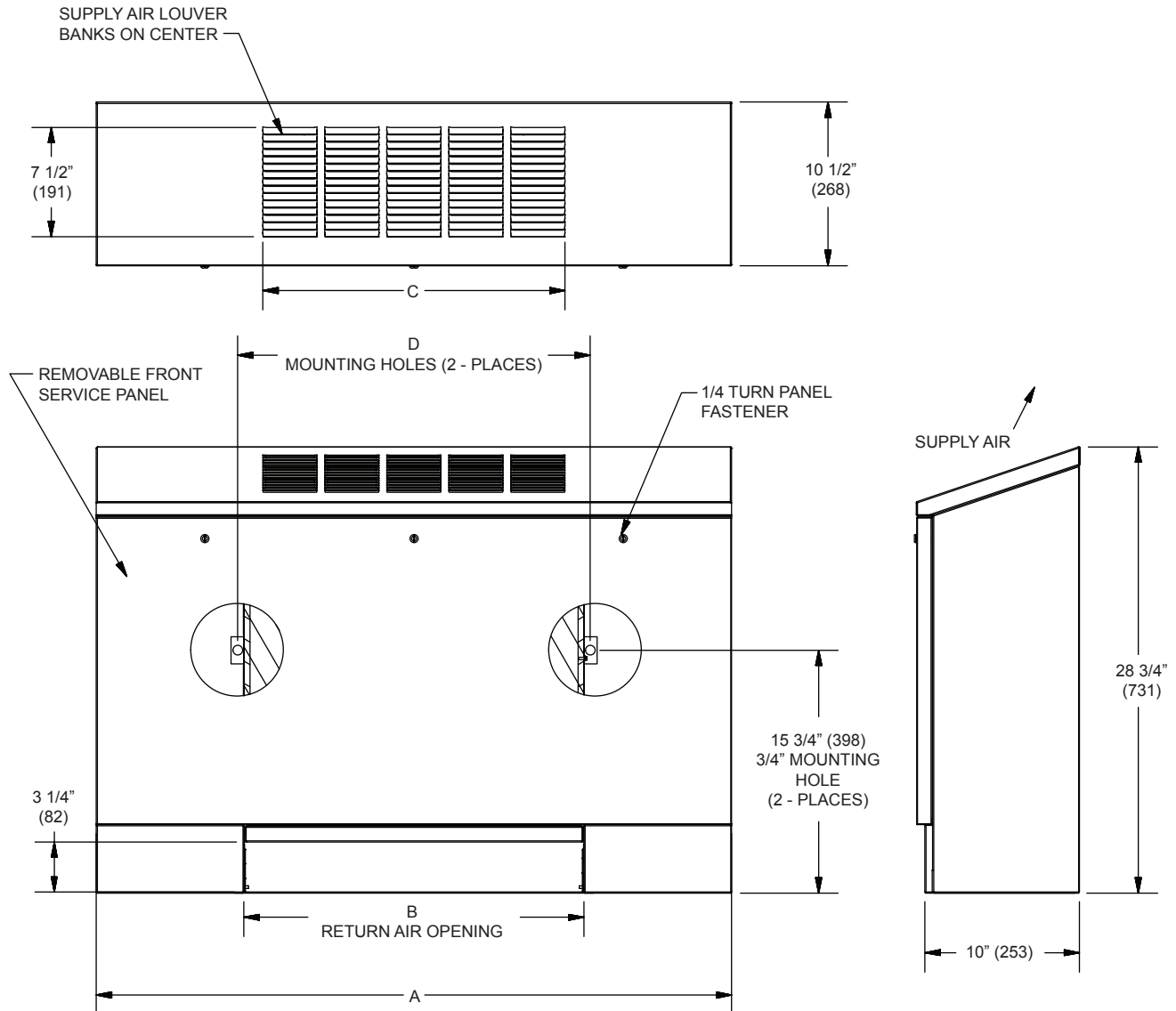

DIMENSIONAL REFERENCES

Unit Size	A	B	C	D
02	40" (1016)	22" (559)	19 1/2" (495)	22 3/4" (578)
03	44" (1118)	26" (660)	23 1/2" (597)	26 3/4" (679)
04	50" (1270)	32" (813)	27 1/2" (699)	32 3/4" (832)
06	60" (1524)	42" (1067)	39 1/2" (1003)	42 3/4" (1086)
08	62" (1575)	44" (1118)	39 1/2" (1003)	44 3/4" (1137)
10	76" (1930)	58" (1473)	55 1/2" (1410)	58 3/4" (1492)
12	84" (2134)	66" (1676)	63 1/2" (1613)	66 3/4" (1695)

NOTES: All dimensions are in inches (millimeters) and are +/- 1/4" (6mm). Junction box size and location varies with unit features. Control options may be limited. Provide sufficient clearance to access electrical controls and comply with applicable codes and ordinances. Standard cabinet finish is "Pearl White Satin". Right hand unit shown, left hand unit similar, but opposite. Parametric design available to increase Height or Width. (See parametric offerings drawing.) Some control or piping package options may require extended end pockets and/or extended drain pans. (See extended end pocket drawing.) False back extension available.

SECTION 5 - DIMENSIONAL DRAWINGS

KVF SERIES OUTSIDE AIR DAMPERS

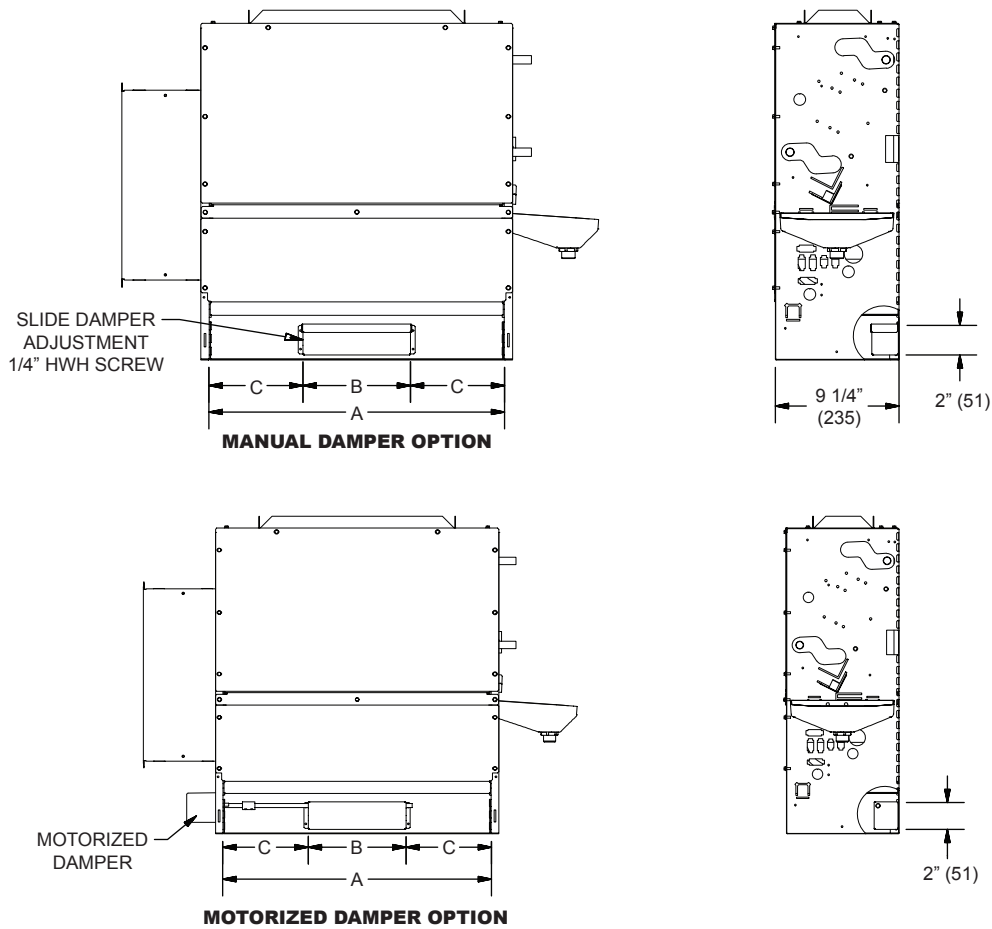

DIMENSIONAL REFERENCES

Unit Size	A	B	C
02	22" (559)	8" (203)	7" (178)
03	26" (660)	10" (254)	8" (203)
04	32" (813)	12" (305)	10" (254)
06	42" (1067)	14" (356)	14" (356)
08	44" (1118)	18" (457)	13" (330)
10	58" (1473)	27" (686)	15 1/2" (394)
12	66" (1676)	27" (686)	19 1/2" (495)

NOTES: All dimensions are in inches (millimeters) and are +/- 1/4" (6). Model KVFH shown; typical for models KVFF and KVFS. Right hand unit shown; left hand unit is similar, but opposite. The standard damper options may not provide freeze protection under all conditions and applications. Other forms of freeze protection may be required.

SECTION 5 - DIMENSIONAL DRAWINGS

KVF SERIES WALL BOX

NON-METALLIC INSECT SCREEN

TOP COVER

BASE PLATE WITH INTEGRAL PAN AND FRONT LOUVER

CENTER SUPPORT AS REQUIRED

SLOPE
SEE NOTE *

6" (152)

2 1/2" (64)

A

Unit Size	A
02	8 1/4" (203)
03	10 1/4" (260)
04	12 1/4" (311)
06	14 1/4" (362)
08	18 1/4" (464)
10	27 1/4" (692)
12	27 1/4" (692)

NOTES: All dimensions are in inches (millimeters) and are +/- 1/4" (6). Material is .050" aluminum. Wall box should be installed pitched slightly toward exterior surface of wall. "Weep" holes should not be obstructed when sealing box to the wall.

KVF SERIES RETURN AIR TOE KICK

1/2" (11)

4 1/2" (112)

A

Unit Size	Part Number	A
02	51-00437-01	22 3/4" (578)
03	51-00437-02	26 3/4" (679)
04	51-00437-03	32 3/4" (832)
06	51-00437-04	42 3/4" (1086)
08	51-00437-05	44 3/4" (1137)
10	51-00437-06	58 3/4" (1792)
12	51-00437-07	66 3/4" (1695)

NOTES: All dimensions are in inches (millimeters) and are +/- 1/4" (6). Typical for KVFF or KVFS models. Return grille is held in place with sheet metal screws.

SECTION 5 - DIMENSIONAL DRAWINGS

KVFF PARAMETRIC INCREMENTS

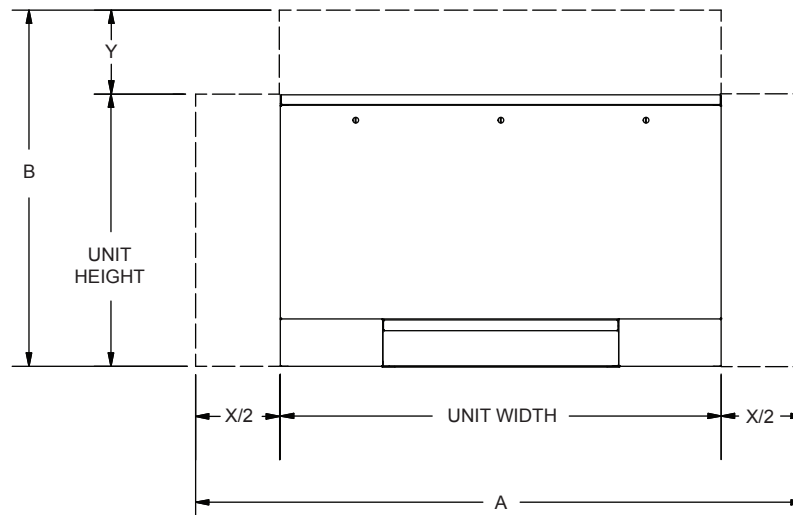

DIMENSIONAL REFERENCES

Dimension A													
Unit Size	X=0	X=1" (25)	X=2" (51)	X=3" (76)	X=4" (102)	X=5" (127)	X=6" (152)	X=7" (178)	X=8" (203)	X=9" (229)	X=10" (254)	X=11" (279)	X=12" (305)
02	40" (1016)	42" (1067)	43" (1092)	44" (1118)	45" (1143)	46" (1168)	47" (1194)	48" (1219)	49" (1245)	50" (1270)	51" (1295)	52" (1321)	53" (1346)
03	44" (1118)	46" (1168)	47" (1194)	48" (1219)	49" (1245)	50" (1270)	51" (1295)	52" (1321)	53" (1346)	54" (1372)	55" (1397)	56" (1422)	57" (1448)
04	50" (1270)	52" (1321)	53" (1346)	54" (1372)	55" (1397)	56" (1422)	57" (1448)	58" (1473)	59" (1499)	60" (1524)	61" (1549)	62" (1575)	63" (1600)
06	60" (1524)	62" (1575)	63" (1600)	64" (1626)	65" (1651)	66" (1676)	67" (1702)	68" (1727)	69" (1753)	70" (1778)	71" (1803)	72" (1829)	73" (1854)
08	62" (1575)	64" (1626)	65" (1651)	66" (1676)	67" (1702)	68" (1727)	69" (1753)	70" (1778)	71" (1803)	72" (1829)	73" (1854)	74" (1880)	75" (1905)
10	76" (1930)	78" (1981)	79" (2007)	80" (2032)	81" (2057)	82" (2083)	83" (2108)	84" (2134)	85" (2159)	86" (2184)	87" (2210)	88" (2235)	89" (2261)
12	84" (2134)	86" (2184)	87" (2210)	88" (2235)	89" (2261)	90" (2286)	91" (2311)	92" (2337)	93" (2362)	94" (2388)	95" (2413)	-	-
Dimension B													
All Sizes	Y=0	Y=1" (25)	Y=2" (51)	Y=3" (76)	Y=4" (102)	Y=5" (127)	Y=6" (152)	Y=7" (178)	Y=8" (203)	Y=9" (229)	Y=10" (254)	Y=11" (279)	Y=12" (305)
	25 1/4" (641)	26 1/4" (667)	27 1/4" (692)	28 1/4" (718)	29 1/4" (743)	30 1/4" (768)	31 1/4" (794)	32 1/4" (819)	33 1/4" (845)	34 1/4" (870)	35 1/4" (895)	36 1/4" (921)	37 1/4" (946)

NOTES: All dimensions are in inches (millimeters) and are +/- 1/4" (6mm). Internal chassis and air openings remain the same. External cabinet can increase in height and width in 1" (25.4mm) increments up to 12" (305mm).

SECTION 5 - DIMENSIONAL DRAWINGS

KVFS PARAMETRIC INCREMENTS

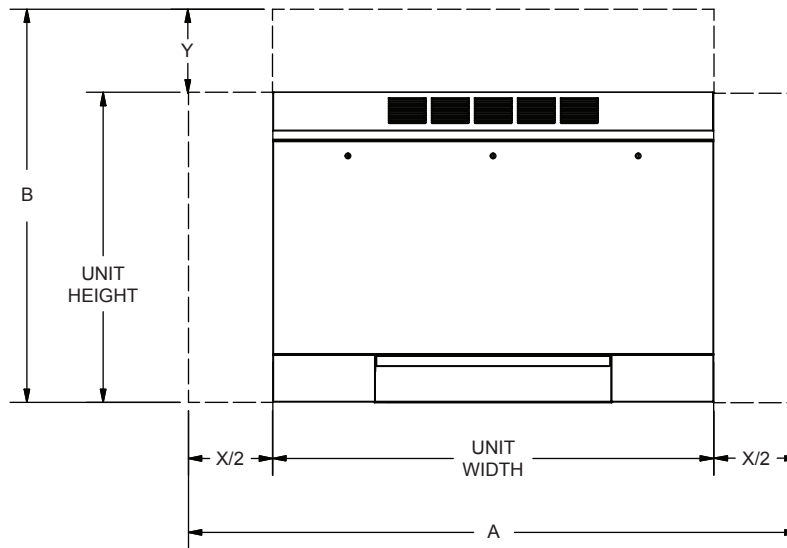

DIMENSIONAL REFERENCES

Dimension A													
Unit Size	X=0	X=1" (25)	X=2" (51)	X=3" (76)	X=4" (102)	X=5" (127)	X=6" (152)	X=7" (178)	X=8" (203)	X=9" (229)	X=10" (254)	X=11" (279)	X=12" (305)
02	40" (1016)	42" (1067)	43" (1092)	44" (1118)	45" (1143)	46" (1168)	47" (1194)	48" (1219)	49" (1245)	50" (1270)	51" (1295)	52" (1321)	53" (1346)
03	44" (1118)	46" (1168)	47" (1194)	48" (1219)	49" (1245)	50" (1270)	51" (1295)	52" (1321)	53" (1346)	54" (1372)	55" (1397)	56" (1422)	57" (1448)
04	50" (1270)	52" (1321)	53" (1346)	54" (1372)	55" (1397)	56" (1422)	57" (1448)	58" (1473)	59" (1499)	60" (1524)	61" (1549)	62" (1575)	63" (1600)
06	60" (1524)	62" (1575)	63" (1600)	64" (1626)	65" (1651)	66" (1676)	67" (1702)	68" (1727)	69" (1753)	70" (1778)	71" (1803)	72" (1829)	73" (1854)
08	62" (1575)	64" (1626)	65" (1651)	66" (1676)	67" (1702)	68" (1727)	69" (1753)	70" (1778)	71" (1803)	72" (1829)	73" (1854)	74" (1880)	75" (1905)
10	76" (1930)	78" (1981)	79" (2007)	80" (2032)	81" (2057)	82" (2083)	83" (2108)	84" (2134)	85" (2159)	86" (2184)	87" (2210)	88" (2235)	89" (2261)
12	84" (2134)	86" (2184)	87" (2210)	88" (2235)	89" (2261)	90" (2286)	91" (2311)	92" (2337)	93" (2362)	94" (2388)	95" (2413)	-	-
Dimension B													
All Sizes	Y=0	Y=1" (25)	Y=2" (51)	Y=3" (76)	Y=4" (102)	Y=5" (127)	Y=6" (152)	Y=7" (178)	Y=8" (203)	Y=9" (229)	Y=10" (254)	Y=11" (279)	Y=12" (305)
	25 1/4" (641)	26 1/4" (667)	27 1/4" (692)	28 1/4" (718)	29 1/4" (743)	30 1/4" (768)	31 1/4" (794)	32 1/4" (819)	33 1/4" (845)	34 1/4" (870)	35 1/4" (895)	36 1/4" (921)	37 1/4" (946)

NOTES: All dimensions are in inches (millimeters) and are +/- 1/4" (6mm). Internal chassis and air openings remain the same. External cabinet can increase in height and width in 1" (25.4mm) increments up to 12" (305mm).

SECTION 5 - DIMENSIONAL DRAWINGS

KVFH, WALL RECESSING PANEL, FRONT SUPPLY, RETURN

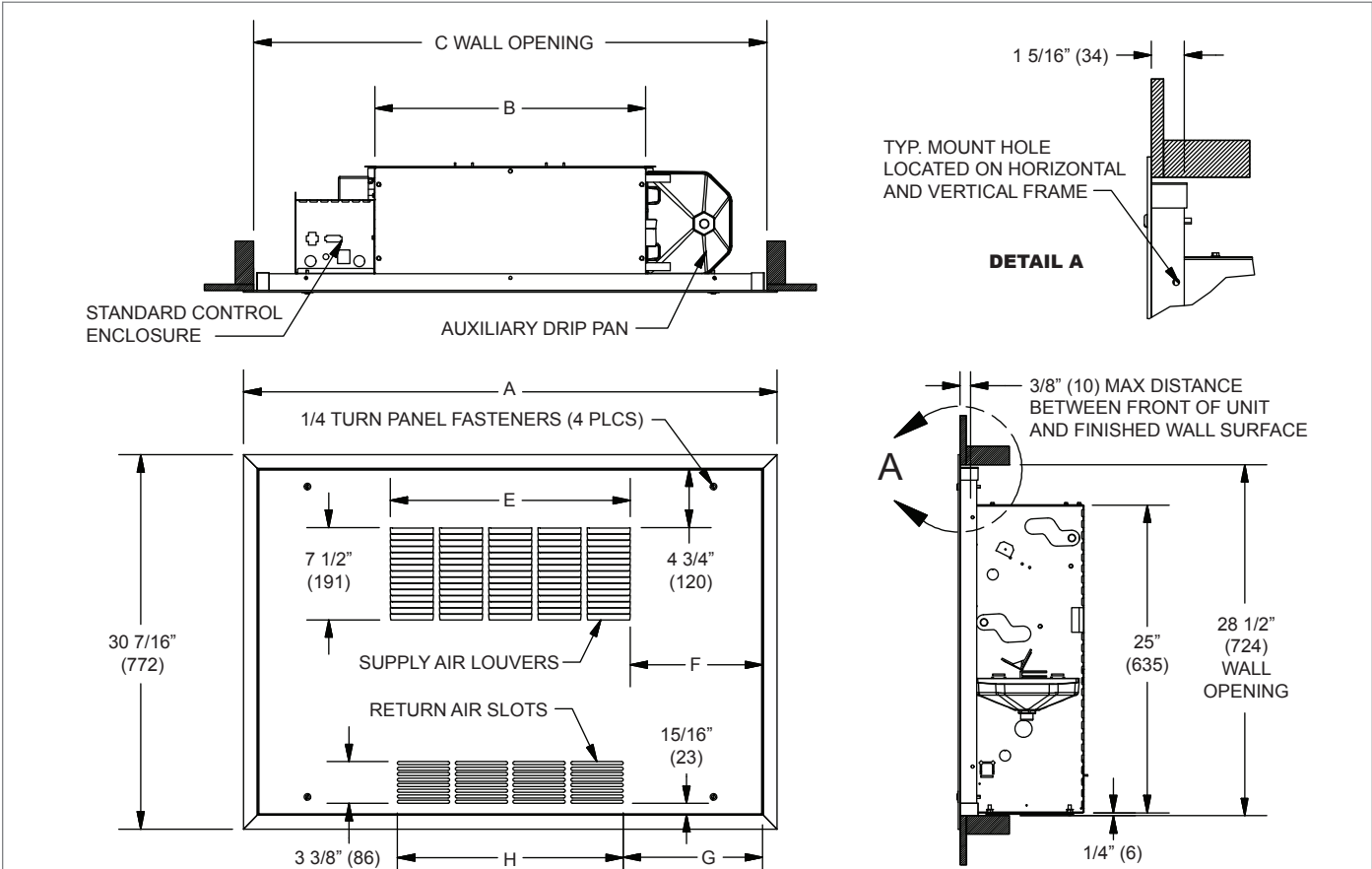

DIMENSIONAL REFERENCES

Unit Size	A	B	C	D	E	F	G
02	43 7/16" (1101)	22" (559)	41 11/16" (1059)	18 3/8" (1059)	19 1/2" (495)	10 3/4" (273)	11 5/16" (288)
03	47 7/16" (1203)	26" (660)	45 11/16" (1160)	23 1/16" (1059)	23 1/2" (597)	10 3/4" (273)	11" (279)
04	53 7/16" (1355)	32" (813)	51 11/16" (1313)	27 3/4" (1059)	27 1/2" (699)	11 3/4" (298)	11 5/8" (295)
06	63 7/16" (1609)	42" (1067)	61 11/16" (1567)	37 1/8" (1059)	39 1/2" (1003)	10 3/4" (273)	11 15/16" (303)
08	65 7/16" (1660)	44" (1118)	63 11/16" (1618)	41 7/8" (1059)	39 1/2" (1003)	11 3/4" (298)	10 9/16" (269)
10	79 7/16" (2015)	58" (1473)	77 11/16" (1973)	55 15/16" (1059)	55 1/2" (1410)	10 3/4" (273)	10 9/16" (269)
12	87 7/16" (2219)	66" (1676)	85 11/16" (2176)	60 5/8" (1059)	63 1/2" (1613)	10 3/4" (273)	12 3/16" (309)

NOTES: All dimensions are in inches (millimeters) and are +/- 1/4" (6mm). Wall panel provides air seal at front of unit. Installed location is critical to proper unit operation. Install unit centered in wall opening dimensions shown. Unit may require raised support to achieve proper vertical alignment with wall panel. Right hand unit shown, left hand unit opposite. Mounting hardware furnished by others.

SECTION 5 - DIMENSIONAL DRAWINGS

KVFF / KVFS FALSE BACK INSTALLATION INSTRUCTIONS

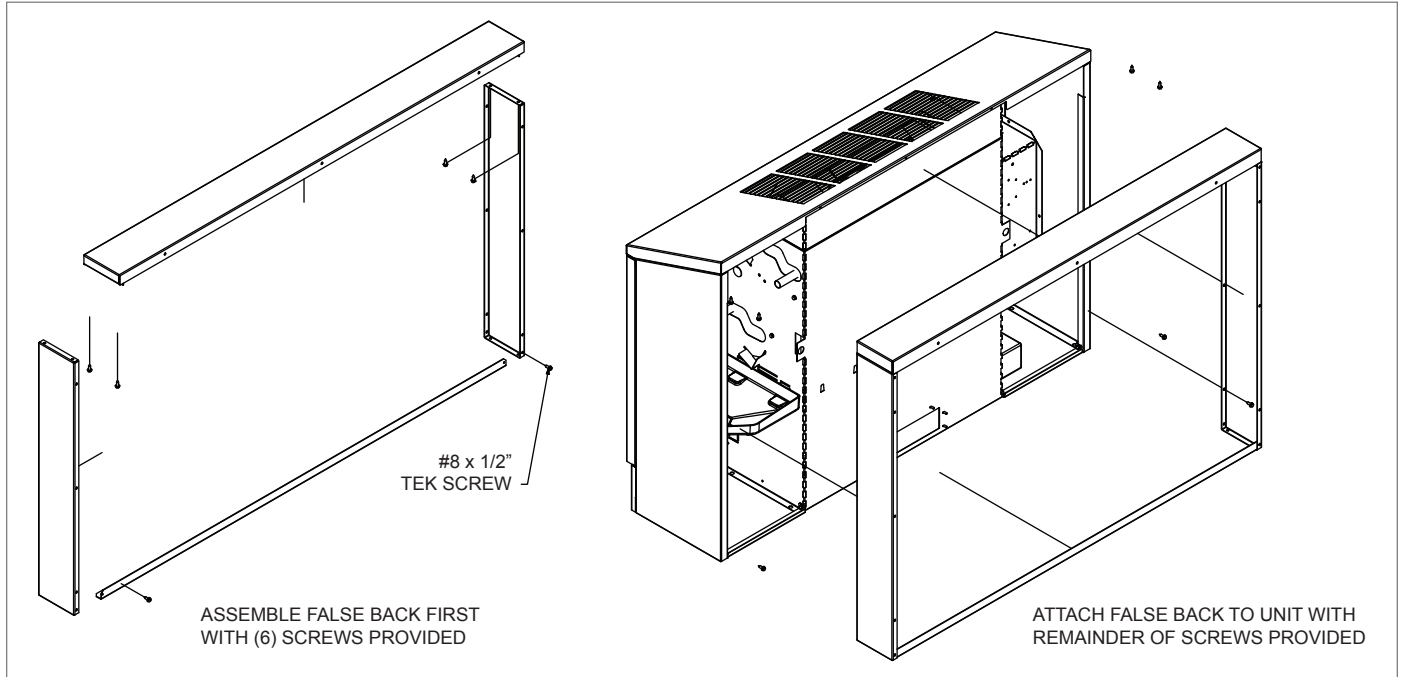

KVF PIPING PACKAGE SPACE CONSTRAINTS

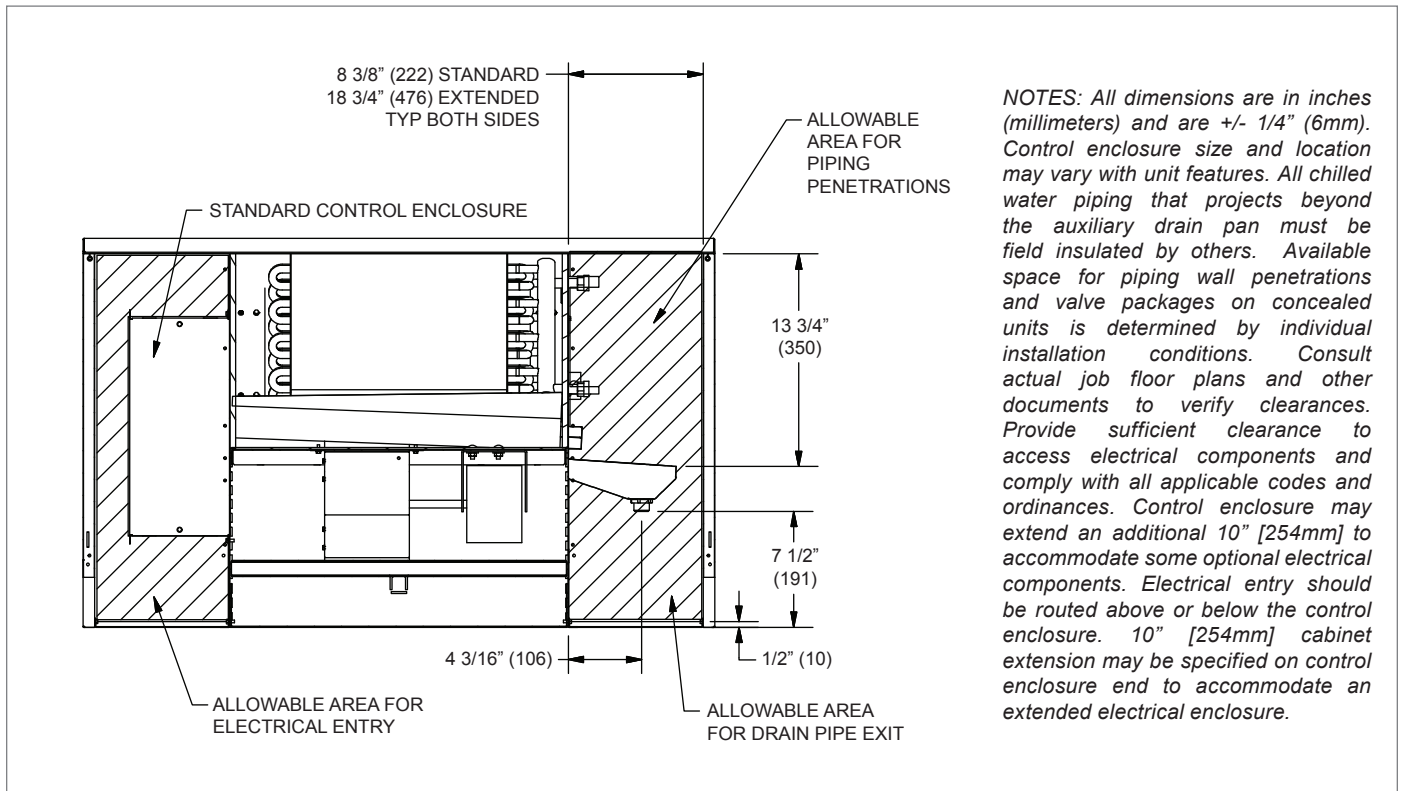

SECTION 5 - DIMENSIONAL DRAWINGS

COIL CONNECTION LOCATIONS, 2-PIPE

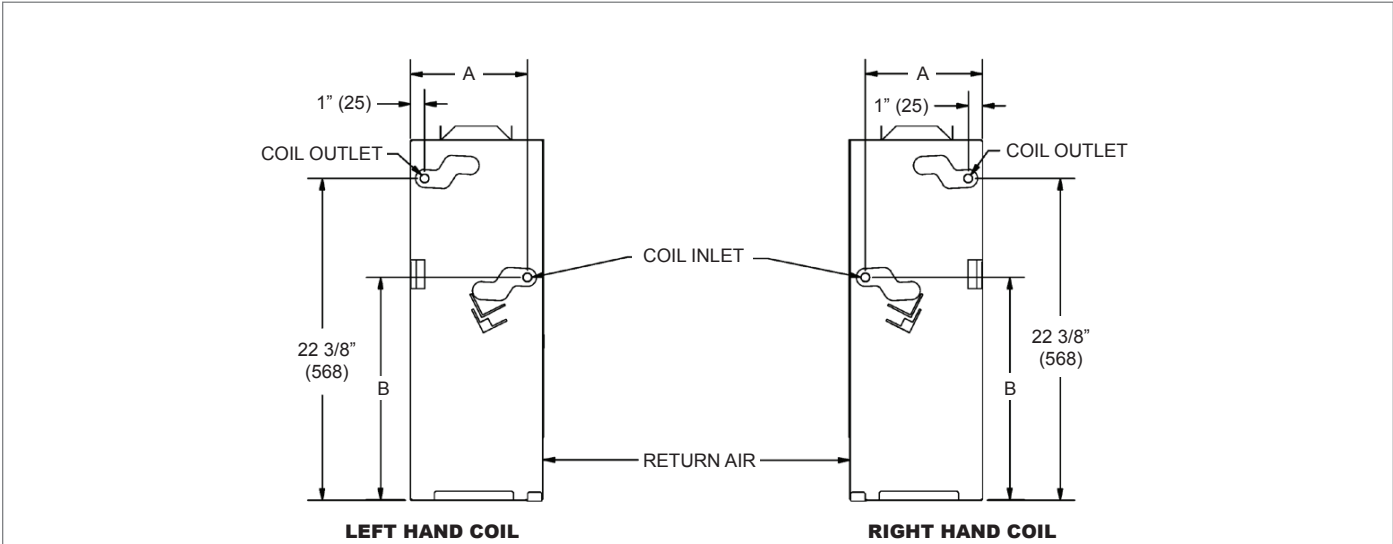

DIMENSIONAL REFERENCES

Coil #1	Dimension		Coil Rows			
			HW Only 1-Row	CW / HW 2-Rows	CW / HW 3-Rows	CW / HW 4-Rows*
Supply	A		6.00" (152)	7.25" (184)	7.87" (200)	8.12" (206)
	B		14.57" (370)	14.64" (372)	15.68" (398)	15.5" (394)

NOTES: All dimensions are in inches (millimeters) and are +/- 1/4" (6mm). All coils are 5/8" (actual) connections. 4-Row coil not available with Electric Heat.

SECTION 5 - DIMENSIONAL DRAWINGS

COIL CONNECTION LOCATIONS, 4-PIPE

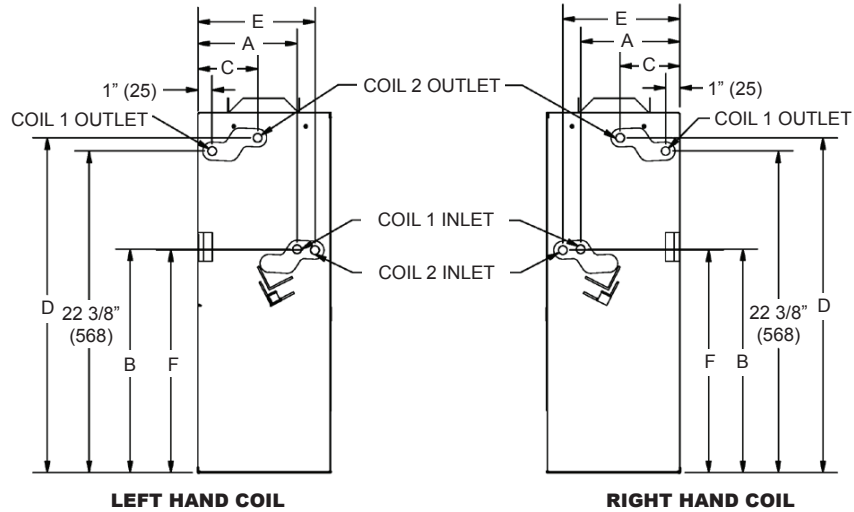

DIMENSIONAL REFERENCES

Coil #1	Dimension		Coil Rows		
			HW Only 1-Row	CW / HW 2-Rows	CW / HW 3-Rows*
Supply	A		6.00" (152)	7.25" (184)	7.87" (200)
	B		14.57" (370)	14.64" (372)	15.68" (398)

Coil #2	Dimension		CW Only 2-Rows	CW Only 3-Rows	CW / HW 1-Row	CW / HW 2-Rows	CW / HW 1-Row
			Return	C	2.22" (56)	2.22" (56)	2.90" (74)
	D	22.30" (566)		22.30" (566)	23.35" (175)	23.35" (593)	23.28" (591)
	Supply	E	6.88" (175)	8.13" (207)	6.88" (175)	8.13" (207)	8.13" (207)
F		15.55" (395)	15.45" (391)	15.55" (395)	15.45" (391)	15.45" (391)	

NOTES: All dimensions are in inches (millimeters) and are +/- 1/4" (6mm). All coils are 5/8" (actual) connections.

SECTION 5 - DIMENSIONAL DRAWINGS

TROUBLE SHOOTING GUIDE FOR FAN COIL RELAY BOARD

- Ensure no wires are floating loosely in product. Verify all wires are connected properly on relay board.
- Measure input voltage on relay board as indicated:
 - P1– P2 = 115V
 - P1– P4 = 230V
 - P7– P6 = 115V
 - P9– P6 = 230V
 - P1– P3 = 208V
 - P1– P5 = 277V
 - P8– P6 = 208V
 - P10– P6 = 277V
- Ensure “MTR PWR” is connected to correct voltages (115V/P7, 208V/P3, 230V/P4, or 277V/P5). See below.



NOTE - Motor power can only be connected to one voltage.

FIGURE 11: KVF FAN COIL RELAY BOARD WITH MOTOR POWER CONNECTIONS

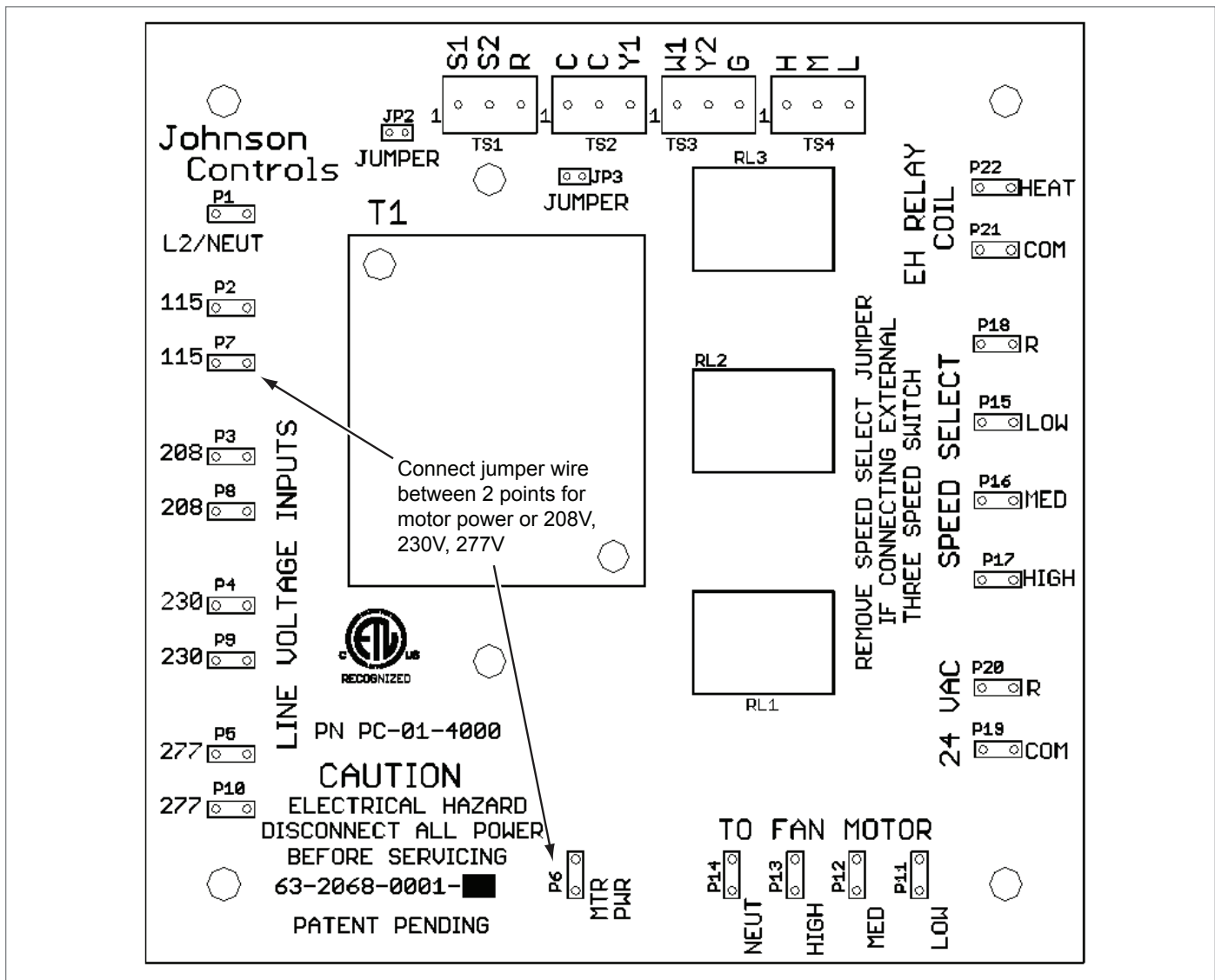

SECTION 5 - DIMENSIONAL DRAWINGS

TROUBLE SHOOTING GUIDE FOR FAN COIL RELAY BOARD (CONTINUED)

- Verify fan speed will change from High, Medium, and Low by utilizing remote 3 speed switch, thermostat or connecting by P18 to P15, P18 to P16, or P18 to P17. If fan speeds are adjustable the relay board is producing 24 Volts.
- If board is not working, measure 24 volts between P20 and P19, if 24 volts (19-29 VAC) is not present then measure across terminals S1 and R, if 24 volts (19-29 VAC) is not present then return board to local sales representative.
- Verify plug jumper JP3 (Figure 12) is installed or wire is installed between W2 and R.



NOTE - Either JP3 or wire jumper must always be installed unless thermostat drawing indicates otherwise.



NOTE - JP3 should be removed for single speed operation using "G" terminal.



NOTE - For thermostat with 3 speed switching, remove JP1 but leave JP3 installed.

FIGURE 12: KVF FAN COIL RELAY BOARD

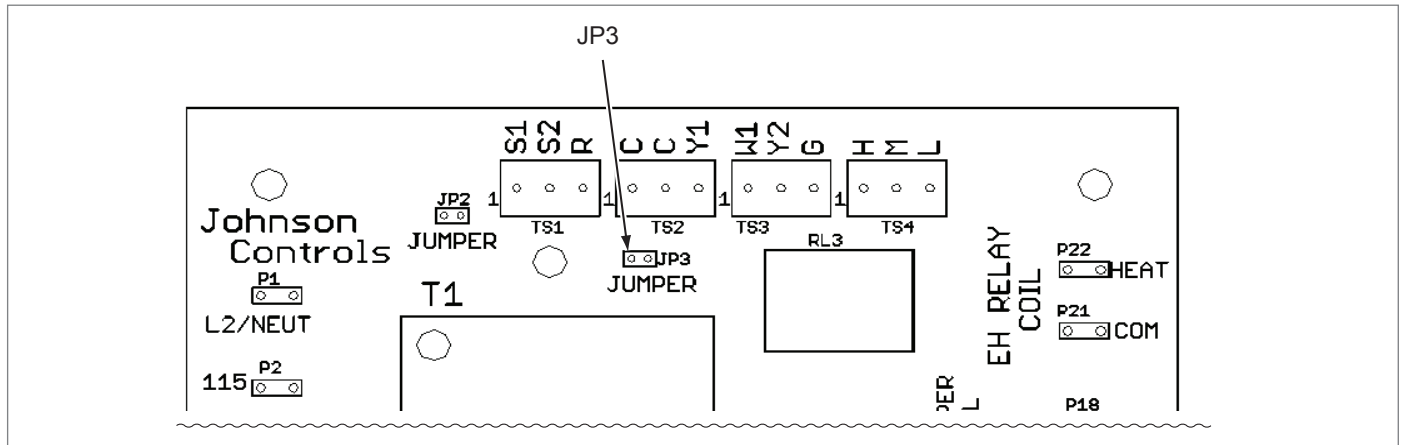

- **S1** – Common side of transformer. Jumped to "C" (common) through JP2. If application calls for float switch JP2 is removed and float switch is connected between S1 and C.
- **S2** – Convenience terminal. Not connected to other components on the board. Used for different functions based on application, such as 2nd stage heat control tie point for two stage EH applications, or changeover water valve/aquastat tie point for two pipe changeover applications. May also be used as tie point for "Close" input of modulating hot water valve actuator and "Close" output of thermostat in floating [tristate] water valve applications.
- **R** – Transformer "hot" connection (side of transformer that's not the one used for valve actuator, EH, etc. commons). Control outputs to board should close to "R" to energize (Refer to thermostat literature. At least one thermostat, the Johnson Controls T600/TEC model line is known to use the "R" for valve common but the "C" for fan speed common. This is the only known (by JCI Largo Engineering) case in which this occurs. All other thermostats dealt with use the "C" for all device commons).
- **C** – Device common, including onboard speed relays (all terminals "C" and "COM" on board are tied together).
- **C** – Device common.
- **Y1** – Tie point for chilled water valve actuator control input, and thermostat cooling output. Convenience terminal, not connected to anything else on board.
- **W1** – Tie point for hot water valve actuator or 1st stage EH control input, and thermostat heating output. Convenience terminal, tied to P22 "Heat" quick connect for factory termination to EH relay if applicable.
- **Y2** – Tie point for "Close" input of modulating chilled water valve actuator or 2nd stage chilled water valve actuator control input, and thermostat cooling output. Convenience terminal, not connected to anything else on board. Y1 is "Open" output if floating [tristate] chilled water valve actuator is supplied (or used).
- **G** – Connected to "R" thru JP3. Used (with JP3 removed) for input from single speed (residential style) thermostats that do not supply three speed fan switching. In these applications, a separate three speed switch may be used with the "H", "M" or "L" inputs, of the provided jumper to set a fixed fan speed. If thermostat supports three speed switching, "H", "M" and "L" inputs should be used, and JP3 should remain in place.
- **H** – High speed control input for onboard relay. Parallels the P17 "HIGH" quick connect input. If thermostat or independent three speed switch is used, remove jumper JP1 (female to female quick jumper wire).
- **M** – Medium speed control for onboard relay. Parallels the P16 "MED" quick connect input.
- **L** – Low speed control input for onboard relay. Parallels the P15 "LOW" quick connect input.
- **HEAT (P22)** – Same functionality as W1 when operating EH.

SECTION 5 - DIMENSIONAL DRAWINGS

EXAMPLE WIRING DIAGRAM

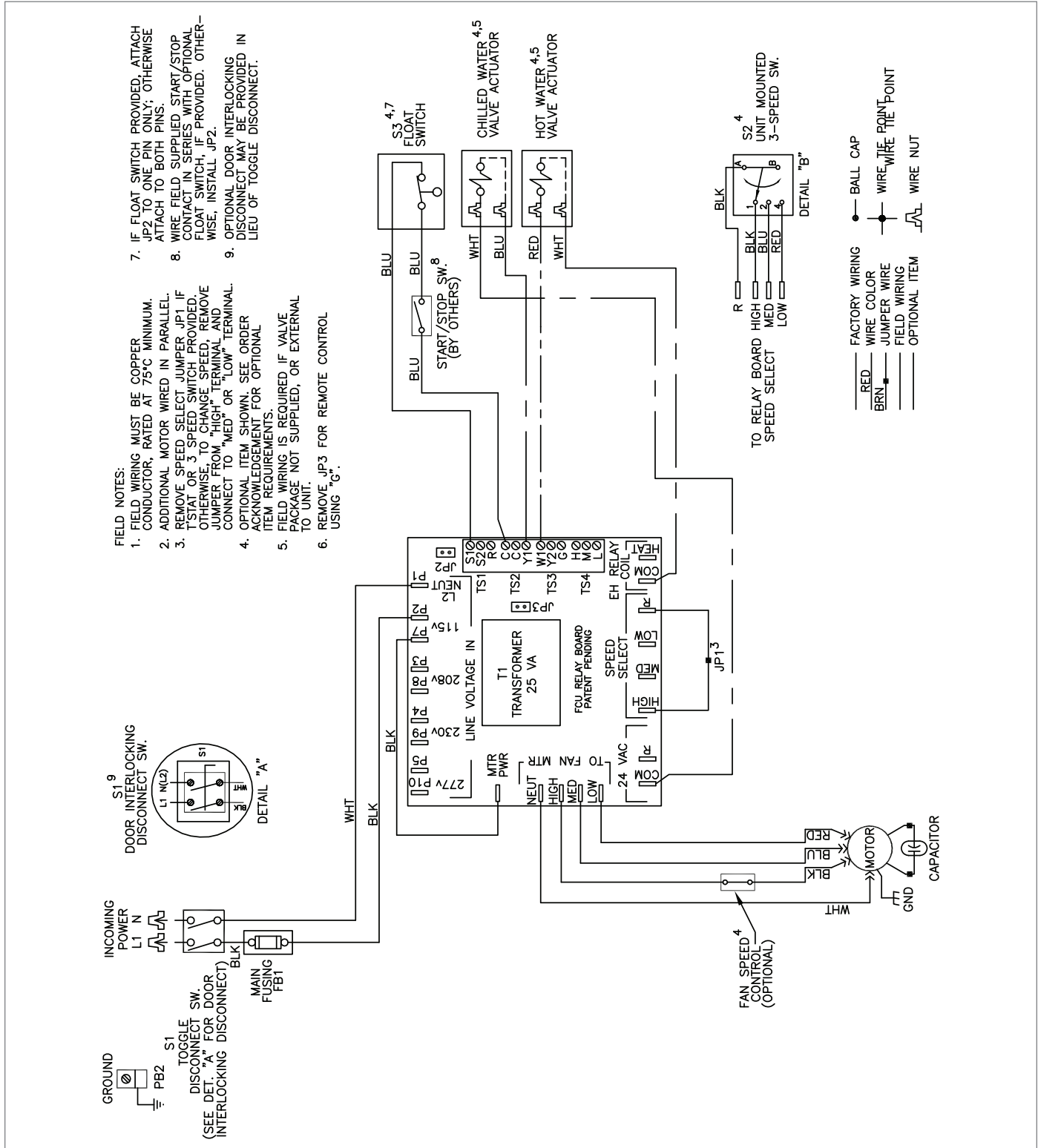



1401 N. Plano Rd. | Richardson, TX 75081 | Tel: 972.680.9136 | Fax: 972.497.0450
www.krueger-hvac.com | kruegerinfo@krueger-hvac.com