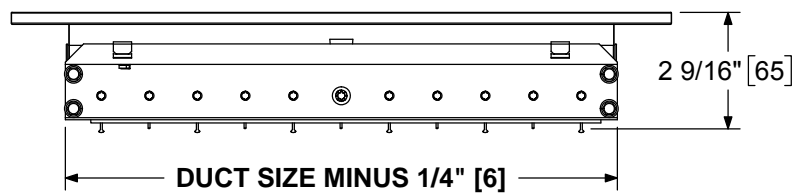
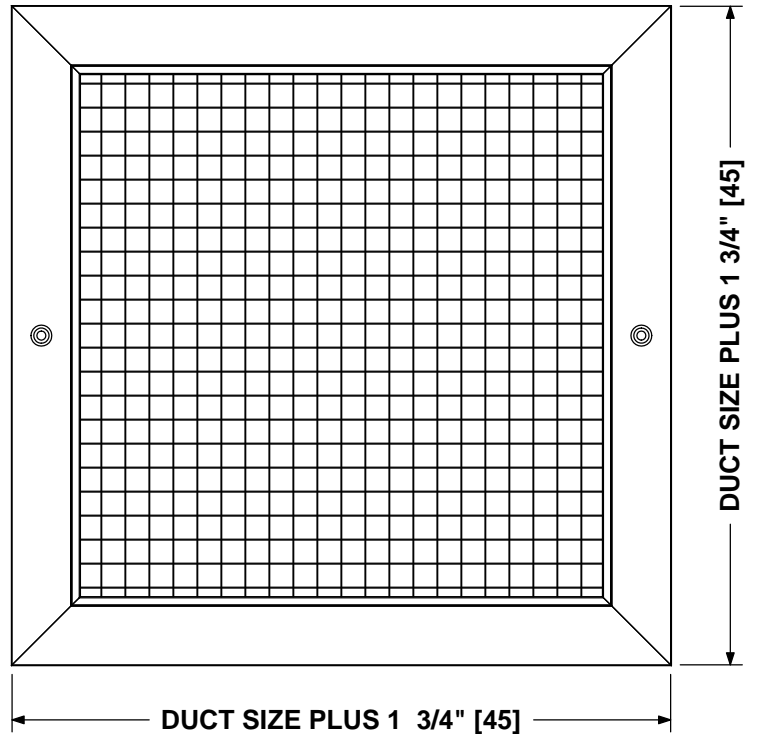
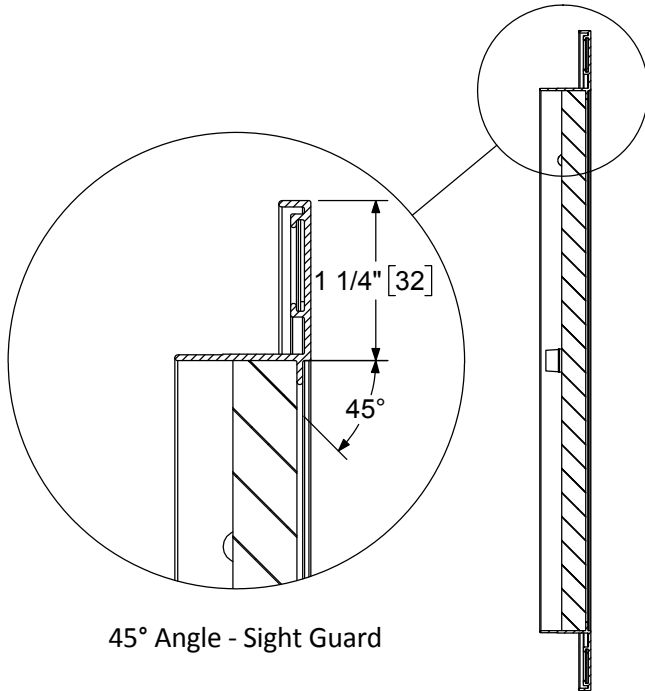
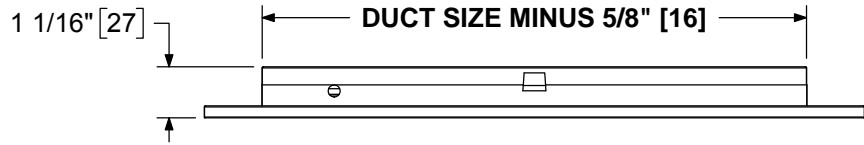

EGC545 SERIES

45° EGGCRATE GRILLE, 1/2" X 1/2" X 1/2" GRID

SUBMITTAL SHEET

AVAILABLE SIZES	
10" X 10"	254 mm x 254 mm
22" X 10"	559 mm x 254 mm
22" X 22"	559 mm x 559 mm
22" X 46"	559 mm x 1168 mm

NOTES:

1. ALUMINUM CONSTRUCTION.
2. STANDARD FINISH 44 BRITISH WHITE.
3. DIMENSIONS ARE IN INCHES.
4. DIMENSIONS IN PARENTHESIS ARE IN MM.
5. EGGCRATE DIMENSIONS 1/2" X 1/2" X 1/2" (13 X 13 X 13).
6. ONLY AVAILABLE IN F22.

ACCESSORIES:

- OBD - STEEL OPPOSED BLADE DAMPER
- POBD - PAINTED STEEL OPPOSED BLADE DAMPER
- 5OBD - ALUMINUM OPPOSED BLADE DAMPER