

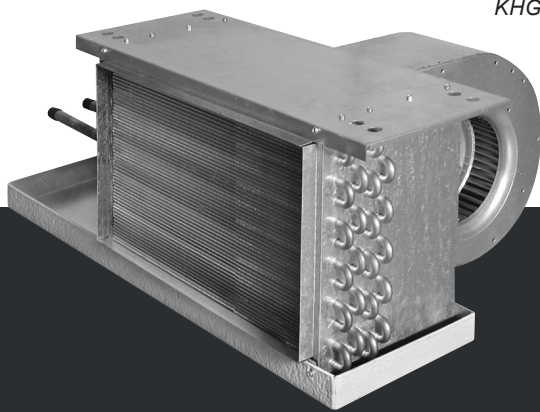

KHGE

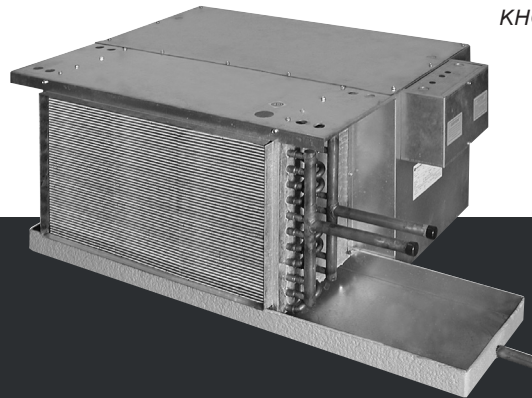

KHGH



KHGP

INSTALLATION GUIDE

Installation, Assembly, Start-up, and Service Instructions

TABLE OF CONTENTS

General Safety Guidelines & Safety Symbols	4
Section 1: Receipt and Initial Installation	5
<i>Preface, Code Compliance, Receipt and Initial Installation, Unpacking and Inspection</i>	<i>-- 5</i>
<i>Handling and Installation, Drain Pan, Auxiliary Drain Pans</i>	<i>-- 6</i>
<i>Return Air Location, Fan Removal, Plenum Box Service Panel</i>	<i>-- 7</i>
<i>Plenum Box Removal, Coil Handling, Coils, Piping Connections, Ductwork Connections</i>	<i>-- 8</i>
<i>Electrical Connections, Control Enclosure, Telescoping Bottom Panel</i>	<i>-- 9</i>
Section 2: Start-up	10
<i>Start-up, Cooling/Heating System, Air System Balancing, Water System Balancing</i>	<i>-- 10</i>
<i>Motor and Fan Data, AHRI Standard Ratings</i>	<i>-- 11</i>
Section 3: Normal Operation and Periodic Maintenance	12
<i>Controls Operation, Physical Data, Motor/Blower Assembly, Fan Assembly, Coil</i>	<i>-- 12</i>
<i>Unit Weights, Electric Heater Resistance Assembly, Electrical Wiring & Controls</i>	<i>-- 13</i>
<i>Electrical Calculations</i>	<i>-- 14</i>
<i>Valves & Piping, Drain, Filters, Filter Replacement</i>	<i>-- 15</i>
<i>Replacement Parts</i>	<i>-- 16</i>
<i>Dimensional Information</i>	<i>-- 17</i>
<i>ECM Motor Balancing Instructions</i>	<i>-- 25</i>
<i>Fan Calibration with ECM Motor</i>	<i>-- 26</i>
<i>ECM Specific Troubleshooting Guidelines, Checking ECM Cables</i>	<i>-- 27</i>
<i>Troubleshooting Guide for Fan Coil Relay Board</i>	<i>-- 29</i>
<i>Example Wiring Diagrams</i>	<i>-- 32</i>
<i>Instructions for Remote Thermostat or Remote 3-Speed Switch</i>	<i>-- 35</i>
Section 4: Inspection and Start-up Checklist	36

CHANGEABILITY OF THIS DOCUMENT

In complying with Krueger's policy for continuous product improvement, the information contained in this document is subject to change without notice. Krueger makes no commitment to update or provide current information automatically to the manual owner. Updated manuals, if applicable, can be obtained on Krueger's website at www.krueger-hvac.com

Operating/service personnel maintain responsibility for the applicability of these documents to the equipment. If there is any question regarding the applicability of these documents, the technician should verify whether the equipment has been modified and if current literature is available from the owner of the equipment prior to performing any work on the unit.

CHANGE BARS

Revisions made to this document are indicated with a line along the left or right hand column in the area the revision was made. These revisions are to technical information and any other changes in spelling, grammar, or formatting are not included.

IMPORTANT!

READ BEFORE PROCEEDING!

GENERAL SAFETY CONSIDERATIONS

The equipment covered by this manual is designed for safe and reliable operation when installed and operated within its design specification limits. To avoid personal injury or damage to equipment or property while installing or operating this equipment, it is essential that qualified, experienced personnel perform these functions using good judgment and safe practices. See the following cautionary statements.

SAFETY SYMBOLS

The following symbols are used in this document to alert the reader to specific situations:



DANGER - DANGER indicates an imminently hazardous situation which, if not avoided, will result in death or serious injury.



CAUTION - CAUTION identifies a hazard which could lead to damage to the machine, damage to other equipment and/or environmental pollution. Usually an instruction will be given, together with a brief explanation.



WARNING - WARNING indicates a potentially hazardous situation which, if not avoided, could result in death or serious injury.



NOTE - NOTE is used to highlight additional information which may be helpful to you.



DANGER - ELECTRICAL SHOCK HAZARDS. All power must be disconnected prior to installation and servicing this equipment. More than one source of power may be present. Disconnect all power sources to avoid electrocution or shock injuries.

DANGER - MOVING PARTS HAZARDS. Motor and Blower must be disconnected prior to opening access panels. Motors can start automatically, disconnect all power and control circuits prior to servicing to avoid serious crushing or dismemberment injuries.

DANGER - HOT PARTS HAZARD. Electric Resistance heating elements must be disconnected prior to servicing. Electric Heaters may start automatically, disconnect all power and control circuits prior to servicing to avoid burns.



WARNING - Check that the unit assembly and component weights can be safely supported by rigging and lifting equipment.



CAUTION - All assemblies must be adequately secured during lifting and rigging by temporary supports and restraints until equipment is permanently fastened and set in its final location.

CAUTION - All unit temporary and permanent supports must be capable of safely supporting the equipment's weight and any additional live or dead loads that may be encountered. All supports must be designed to meet applicable local codes and ordinances

CAUTION - All fastening devices must be designed to mechanically lock the assembly in place without the capability of loosening or breaking away due to system operation and vibration.

CAUTION - Protect adjacent flammable materials when brazing. Use flame and heat protection barriers where needed. Have fire extinguisher available and ready for immediate use.

SECTION 1 - RECEIPT AND INITIAL INSTALLATION

PREFACE

Krueger fan coils represent a prudent investment which can, with proper installation, operation, and regular maintenance, give trouble-free operation and long service.

Your equipment is initially protected under the manufacturer's standard warranty; however, this warranty is provided under the condition that the steps outlined in this manual for initial inspection, proper installation, regular periodic maintenance, and everyday operation of the equipment be followed in detail. This manual should be fully reviewed in advance of any actual work being done on the equipment. Should any questions arise, please contact your local Sales Representative or the factory BEFORE proceeding.

The equipment covered by this manual is available with a vast variety of options and accessories. Consult the approved unit submittal, order acknowledgement, and other manuals for details on the options and accessories provided with the equipment on each project.

CODE COMPLIANCE

This equipment has been manufactured and certified in accordance with UL 1995-Standard for Safety, Heating and Cooling Equipment (CAN/CSA C22.2 NO 236- M90) and bears the Electrical Testing Laboratories (ETL) Mark under ETL File No: 3036742-002.

RECEIPT AND INITIAL INSTALLATION



WARNING - No attempt should be made to handle, install, or service any unit without following safe practices regarding mechanical equipment.

- All power must be disconnected before any installation or service should be attempted. More than one power source may be supplied to a unit. Power to remote mounted control devices may not be supplied through the unit. Never wear bulky or loose fitting clothing when working on any mechanical equipment. Gloves should only be worn when required for proper protection from heat or other possible injury. Safety glasses or goggles should always be worn when drilling, cutting, or working with chemicals such as refrigerants or lubricants.
- Never pressurize any equipment beyond specified operating pressures. Always pressure test with an inert fluid or gas such as clear water or dry nitrogen to avoid possible damage or injury in the event of a leak or component failure during testing. Always protect adjacent flammable material when welding or soldering. Use suitable heat shield material to contain

sparks or drops of solder. Have fire extinguisher available for use when welding or brazing.

The manufacturer assumes no responsibility for personal injury or property damage resulting from improper or unsafe practices during the handling, installation, service, or operation of any equipment.

UNPACKING & INSPECTION

All units are carefully inspected at the factory throughout the manufacturing process under a strict detailed quality assurance program, and where possible, all major components and subassemblies are carefully tested for proper operation and verified to be in full compliance with the factory manufacturing documents. Customer furnished components such as control valves, switches and DDC controls are not factory tested.

Each unit is carefully packaged for shipment to avoid damage during normal transport and handling. The equipment should always be stored in a dry place in the proper orientation as marked on the carton.

All shipments are made F.O.B. factory and it is the responsibility of the receiving party to inspect the equipment upon arrival. Any obvious damage to the carton and/or its contents should be recorded on the bill of lading and a claim should be filed with the freight carrier.

After determining the condition of the carton exterior, carefully remove each unit from the carton and inspect for hidden damage. At this time check to make sure that "furnished only" items such as switches, thermostats, etc. are accounted for. Any hidden damage should be recorded and immediately reported to the carrier and a claim filed as before. In the event a claim for shipping damage is filed, the unit, shipping carton, and all packing must be retained for physical inspection by the freight carrier. All equipment should be stored in the factory shipping carton with internal packing in place until installation.

At the time of receipt, the equipment type and arrangement should be verified against the order documents. Should any discrepancy be found, the local Sales Representative should be notified immediately so that the proper action may be instituted. Should any question arise concerning warranty repairs, the factory must be notified BEFORE any corrective action is taken. Where local repairs or alterations can be accomplished, the factory must be fully informed as to the extent and expected cost of those repairs before work is begun. Where factory operations are required, the factory must be contacted for authorization to return equipment and a Return Authorization Number will be

SECTION 1 - RECEIPT AND INITIAL INSTALLATION

issued. Unauthorized return shipments of equipment and shipments not marked with an authorization number will be refused. In addition, the manufacturer will not accept any claims for unauthorized expenses.

HANDLING & INSTALLATION

While all equipment is designed for durability and fabricated for sturdy construction and may present a rugged appearance, great care must be taken to assure that no force or pressure be applied to the coil, piping or drain stub-outs during handling. Also, depending on the options and accessories, some units could contain delicate components that may be damaged by improper handling. Wherever possible, all units should be maintained in an upright position and handled by the chassis as close as possible to the mounting point locations.

In the case of a full cabinet unit, the unit must obviously be handled by the exterior casing. This is acceptable providing the unit is again maintained in an upright position and no impact forces are applied that may damage internal components, access panels, or painted surfaces. The equipment covered in this manual IS NOT suitable for outdoor installations or hazardous/explosive environments. The equipment should never be stored or installed where it may be subjected to a hostile environment such as rain, snow, extreme temperatures or corrosive or chemical laden atmospheres.

During and after installation, special care must be taken to prevent foreign material such as paint, plaster, and drywall dust from being deposited in the drain pan or on the motor or blower wheels. Failure to do so may have serious adverse effects on unit operation and in the case of the motor and blower assembly, may result in immediate or premature failure. All manufacturers' warranties are void if foreign material is allowed to be deposited on the motor or blower wheels of any unit. Some units and/or job conditions may require some form of temporary covering during construction.

While the manufacturer does not become involved in the design and selection of support methods and components, it should be noted that unacceptable system operating characteristics and/or performance might result from improper or inadequate unit structural support. In addition, adequate clearance must be provided for service and removal of the equipment and its accessory components. Anchoring the equipment in place is accomplished by using the mounting points provided and positioning the unit to maintain the unit on a LEVEL plane. All units are supplied with hanging holes for use with all thread rods.

DRAIN PAN

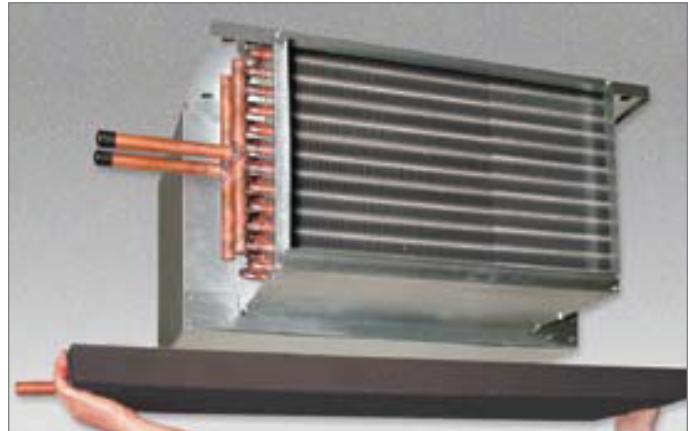

The optional sloped, insulated drain pan can be equipped with a secondary drain connection. Standard drain pans are externally insulated, single wall galvanized steel. The drain pan is easily removable for cleaning. The pan can be turned around 180 degrees for drainage on the opposite side of the valve package(s) while capturing condensate from both the coil and the valve package(s). The optional auxiliary drip pan to catch condensed moisture from valves and piping is easily attachable to the drain pan. The drain pan is equipped with external slots and is to be sloped toward the outlet connection prior to start-up. Care must be taken to insure that the unit drain pan does not slope away from the outlet connection.

AUXILIARY DRAIN PANS

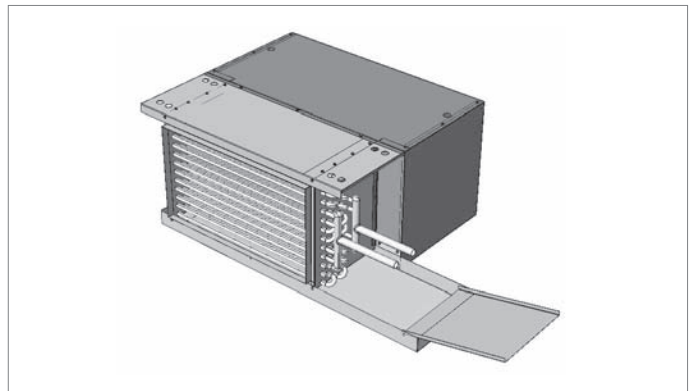

The auxiliary drain pan mounts directly to the unit drain pan using (2) #10 x 1/2" screws.

After the connections are completed, the system should then be tested for leaks. Since some components are not designed to hold pressure with a gas, hydronic systems should be tested with water.

SECTION 1 - RECEIPT AND INITIAL INSTALLATION

! **CAUTION** - All water coils must be protected from freezing after initial filling with water. Even if the system is drained, unit coils may still hold enough water to cause damage when exposed to temperatures below freezing.

Refrigerant systems should be tested with dry nitrogen rather than air to prevent the introduction of moisture into the system. In the event that leaking or defective components are discovered, the Sales Representative must be notified BEFORE any repairs are attempted. All leaks should be repaired before proceeding with the installation.

After system integrity has been established the piping should be insulated in accordance with the project specifications. ALL chilled water piping and valves or refrigerant suction piping not located over drain pans must be insulated to prevent damage from sweating. This includes factory and field piping inside the unit cabinet.

The drain should always be connected and piped to an acceptable disposal point. For proper moisture carryoff, the drain piping should be sloped away from the unit at least 1/8" per foot. A drain trap may be required by local codes and it is strongly recommended for odor containment.

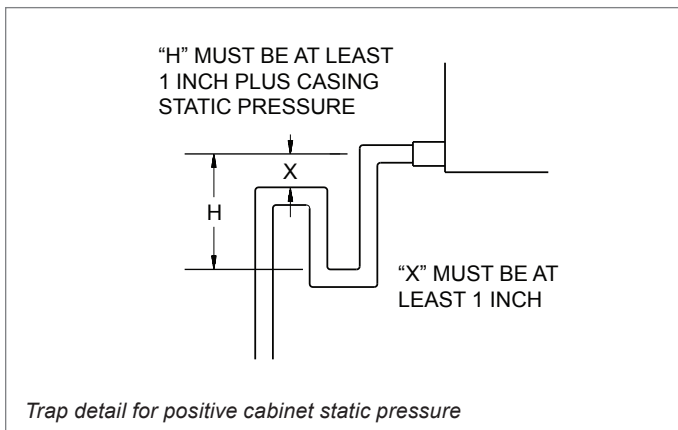

RETURN AIR LOCATION

This unit is equipped with a field reversible rear or bottom ducted air return for plenum style units. To change the return air location, remove the reversible plenum box panel and the filter rack. Rotate both the reversible panel and filter rack 180 degrees. Replace the reversible panel in the old filter rack position and fasten using the supplied screws. Fasten the filter rack to the location where the reversible panel was and replace the filter(s) as described above.

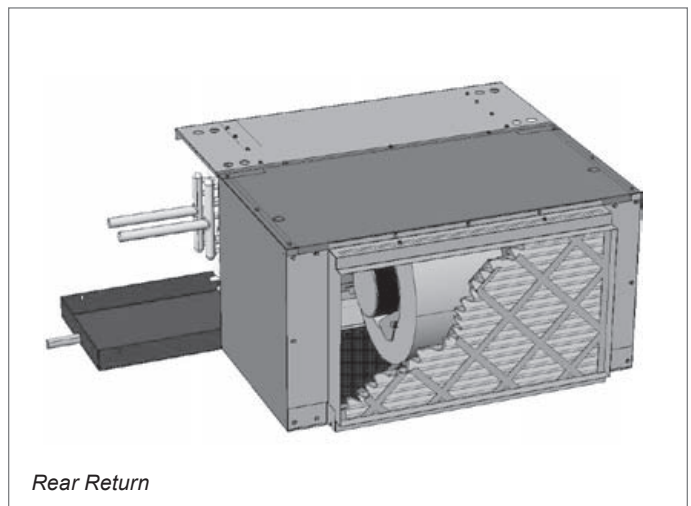
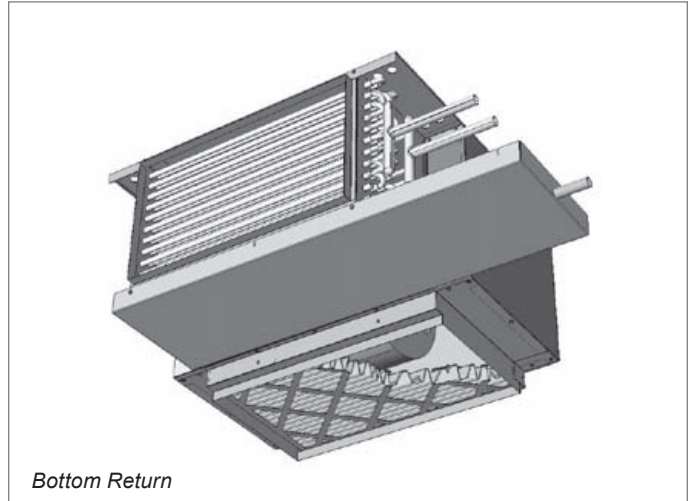

FAN REMOVAL

This fan assembly is easily removable by unscrewing the (4) 1/4-20 nuts from the fan deck and sliding the fan assembly off of the weld studs. Disconnect motor wiring. Reassemble fans and torque nuts to 30 in/lbs.

PLENUM BOX SERVICE PANEL

The service panel on the plenum box is easily removable by removing the screws located on the sides and bottom of the service panel.

SECTION 1 - RECEIPT AND INITIAL INSTALLATION

PLENUM BOX REMOVAL

In most cases this unit is fully serviceable without the need for removal of the plenum box. However should the need arise, the plenum box is easily removable by removing the screws attaching the plenum box to the sides, top and rear of the coil casing.

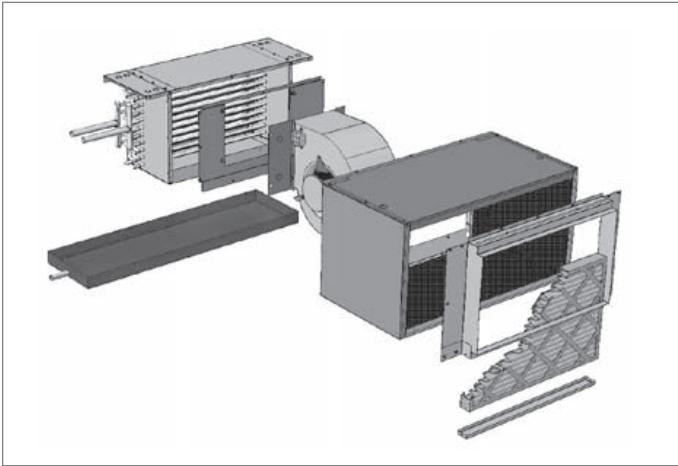

COIL HANDING

This unit features a field reversible coil assembly should the need arise upon installation to change the handing of the coil. To change the coil handing, remove the plenum box (if applicable) from the coil by removing all screws to the coil casing. Next, remove the fan(s), fan deck, and top and bottom casings from the coil. Replace the bottom coil casing in the top coil casing position and the top coil casing in the bottom coil casing position and reattach the fan deck, fan(s) and plenum box (if applicable) in the original locations.



NOTE - The leaving air side of the fin pack will remain the same after changing the coil handing.

COILS

All fan coils are available in 2 or 4 pipe configurations. Heating and cooling coils are field reversible for right or left side connections. On units with water coils, the maximum water pressure applied to the unit should never exceed 300 PSIG at 200°F. On units with steam heating coils, the maximum steam pressure applied to the unit should never exceed 15 PSIG. The drain piping and steam trap should be sized and routed to allow for proper condensate flow. (Minimum ambient temperature 35°F. Coils may freeze.)

PIPING CONNECTIONS



CAUTION - Toxic residues and loose particles resulting from manufacturing and field piping techniques such as joint compounds, soldering flux, and metal shavings may be present in the unit and the piping system. Special consideration must be given to system cleanliness when connecting to solar, domestic or potable water systems.

Submittals and Product Catalogs detailing unit operation, controls, and connections should be thoroughly reviewed BEFORE beginning the connection of the various cooling and/or heating mediums to the unit.

All accessory valve packages should be installed as required, and all valves should be checked for proper operation.

If coil and valve package connections are to be made with “sweat” or solder joint, care should be taken to assure that no components in the valve package are subjected to a high temperature which may damage seals or other materials. Many two-position electric control valves, depending on valve operation, are provided with a manual-opening lever. This lever should be placed in the “open” position during all soldering or brazing operations. Valve bodies should be wrapped with a wet rag to help dissipate heat encountered during brazing. Use a brazing alloy to make connections such as BCup-2. Soft solder is not recommended.

If the valve package connection at the coil is made with a union, the coil side of the union must be prevented from twisting (“backed up”) during tightening to prevent damage to the coil tubing. Over-tightening must be avoided to prevent distorting the union seal surface and destroying the union. In the case of field installed valves and piping, the chilled water valve cluster (or expansion valve on DX units) should be installed in such a way that any dripping or sweating is contained in the auxiliary drain pan or other device. Valves and TXV’s should be secured or supported to avoid damage to coil headers or distributor tubes.

DUCTWORK CONNECTIONS

All ductwork and/or supply and return grilles should be installed in accordance with the project plans and specifications. If not included on the unit or furnished from the factory, Krueger supply and return grilles are available in a variety of types.

SECTION 1 - RECEIPT AND INITIAL INSTALLATION

All units must be installed in non-combustible areas. Some models are designed to be connected to ductwork with a MINIMUM amount of external static pressure. Consult the approved submittals and the product catalog for unit external static pressure limitations.

Units provided with outside air for ventilation should have some form of low temperature protection to prevent coil freeze-up. Outside air should be pretreated for best results.

It should be noted that none of these methods would adequately protect a coil in the event of power failure. The safest method of freeze protection is to use glycol in the proper percent solution for the coldest expected air temperature. Consult glycol supplier literature for correct solution ratios.

The manufacturer assumes no responsibility for undesirable system operation due to improper design, equipment or component selection, and/or installation of ductwork, grilles, and other field supplied components.

ELECTRICAL CONNECTIONS

The electrical service to the unit should be compared to the unit nameplate to verify compatibility. The routing and sizing of all conduit, and the type and sizing of all wiring and other electrical components such as circuit breakers, disconnect switches, etc. should be determined by the individual job requirements and should not be based on the size and/or type of connection provided on the equipment. All installations should be made in compliance with all governing codes and ordinances. Compliance with all codes is the responsibility of the installing contractor. The unit nameplate lists the unit electrical characteristics such as the required supply voltage, fan and heater amperage and required circuit ampacities. The unit-wiring diagram shows all unit and field wiring. Since each project is different and each unit on a project may be different, the installer must be familiar with the wiring diagram and nameplate on the unit BEFORE beginning any wiring. This unit is not acceptable for installation in hazardous/explosive areas.

CONTROL ENCLOSURE

The optional electrical control enclosure provides access to the electrical compartment. This compartment houses all electric heat and control components. Terminal strips are furnished for simple power and control wiring connections. Multiple knockouts allow wiring entries from either side of the compartment.

All components furnished for field installation, by either the factory or the controls contractor should be located and checked for proper function and compatibility. All internal components should be checked for shipping damage and all electrical connections should be tightened to minimize problems during start-up.

Any devices such as fan switches or thermostats that have been furnished from the factory for field installation must be wired in strict accordance with the applicable wiring diagrams. Failure to do so could result in personal injury or damage to components and will void all manufacturers' warranties.

The fan motor(s) should never be controlled by any wiring or device other than the factory furnished switch or thermostat/switch combination, without factory authorization.

All field wiring should be done in accordance with overning codes and ordinances. Any modification of the unit wiring without factory authorization will result in voiding of all factory warranties and will nullify any agency listings.

The manufacturer assumes no responsibility for any damages and/or injuries resulting from improperly field installed or wired components.

TELESCOPING BOTTOM PANEL

The telescoping bottom panel allows for fully recessing the unit while permitting service access into the ceiling plenum. The architectural ceiling panel is finished with a durable powder coat paint.



NOTE - Portions of the inlet louver not directly below unit inlet may require covering in the field on applications where infiltration of ceiling plenum air into space is undesired. Telescoping skirt and collar assembly must be field adjusted to assure a proper fit between filter frame and louvered inlet panel assembly. Refer to assembly submittal drawings for specific dimensions.



SECTION 2 - START-UP

START-UP

Before beginning any start-up operation, the startup personnel should familiarize themselves with the unit, options and accessories, and control sequence to understand the proper system operation. All personnel should have a good working knowledge of general start-up procedures and have the appropriate start-up and balancing guides available for consultation.

The initial step in any startup operation should be a final visual inspection. All equipment, plenums, duct-work, and piping should be inspected to verify that all systems are complete and properly installed and mounted, and that no debris or foreign articles such as paper or drink cans are left in the units or other areas. Each unit should be checked for loose wires, free blower wheel operation, and loose or missing access panels or doors. Except as required during start-up and balancing operations, no fan coil units should be operated without all the proper ductwork attached, supply and return grilles in place, and all access doors and panels in place and secure. A clean filter of the proper size and type must also be installed. Failure to do so could result in damage to the equipment or building and furnishings, and/or void all manufacturers' warranties.

COOLING/HEATING SYSTEM

Prior to the water system start-up and balancing, the chilled/hot water systems should be flushed to clean out dirt and debris, which may have collected in the piping during construction. During this procedure, all unit service valves must be in the closed position. This prevents foreign matter from entering the unit and clogging the valves and metering devices. Strainers should be installed in the piping mains to prevent this material from entering the units during normal operation.

During system filling, air venting from the unit is accomplished by the use of the standard manual or optional automatic, air vent fitting installed on the coil. In the case of the manual air vent fitting, the screw should be turned counterclockwise no more than 1-½ turns to operate the air vent. Automatic air vents may be unscrewed one turn counterclockwise to speed initial venting but should be screwed in for automatic venting after start-up operations.

AIR SYSTEM BALANCING

All ductwork must be complete and connected, and all grilles, filters, access doors and panels must be properly installed to establish actual system operating conditions BEFORE beginning air balancing operations.

Each individual unit and attached ductwork is a unique system with its own operating characteristics. For this reason, air balancing is normally done by balance specialists who are familiar with all procedures required to properly establish air distribution and fan system operating conditions. These procedures should not be attempted by unqualified personnel.

After the proper system operation is established, the actual unit air delivery and the actual fan motor amperage draw for each unit should be recorded in a convenient place for future reference such as the inspection, installation, & start-up check sheet, a copy of which is provided on the back of this manual. Contact the Sales Representative or the factory for additional copies of this sheet.

WATER SYSTEM BALANCING

A complete knowledge of the hydronic system, its components, and controls is essential to proper water system balancing and this procedure should not be attempted by unqualified personnel. The system must be complete and all components must be in operating condition BEFORE beginning water system balancing operations.

Each hydronic system has different operating characteristics depending on the devices and controls in the system. The actual balancing technique may vary from one system to another.

After the proper system operation is established, the appropriate system operating conditions such as various water temperatures and flow rates should be recorded in a convenient place for future reference.

Before and during water system balancing, conditions may exist which can result in noticeable water noise or undesired valve operation due to incorrect system pressures. After the entire system is balanced, these conditions will not exist on properly designed systems.

SECTION 2 - START-UP (CONTINUED)

! **CAUTION** - The air vent provided on the unit is not intended to replace the main system air vents and may not release air trapped in other parts of the system. Inspect the entire system for potential air traps and vent those areas as required, independently. In addition, some systems may require repeated venting over a period of time to properly eliminate air from the system

MOTOR AND FAN DATA

Unit Size	Fan Speed	Motor HP (Qty)		Number of Fans	AMPs @ 120/1/60			AMPs @ 208-230/1/60			AMPs @ 277/1/60		
		PSC	ECM		PSC	ECM		PSC	ECM		PSC	ECM	
						FLA	3-Phase Neutral Current		FLA	3-Phase Neutral Current		FLA	3-Phase Neutral Current
06	High	(1) 1/6	(1) 1/3	1	2.6	5.0	8.7	1.1	2.8	4.8	0.9	2.6	4.5
	Medium	(1) 1/8			2.1			0.9			0.8		
	Low	(1) 1/10			1.8			0.6			0.7		
08	High	(1) 1/4	(1) 1/3	1	3.8	5.0	8.7	1.6	2.8	4.8	1.3	2.6	4.5
	Medium	(1) 1/6			3.3			1.0			0.8		
	Low	(1) 1/8			2.6			0.8			0.7		
10	High	(1) 1/4	(1) 1/3	1	4.9	5.0	8.7	2.2	2.8	4.8	1.9	2.6	4.5
	Medium	(1) 1/5			4.1			1.5			1.2		
	Low	(1) 1/6			3.2			1.1			0.8		
12	High	(2) 1/6	(2) 1/3	2	5.2	10.0	17.3	2.2	5.6	9.7	1.8	5.2	9.0
	Medium	(2) 1/8			4.2			1.8			1.6		
	Low	(2) 1/10			3.6			1.2			1.4		
14	High	(2) 1/4	(2) 1/3	2	7.6	10.0	17.3	3.2	5.6	9.7	2.6	5.2	9.0
	Medium	(2) 1/6			6.6			2.0			1.6		
	Low	(2) 1/8			5.2			1.6			1.4		
16	High	(2) 1/4	(2) 1/3	2	9.8	10.0	17.3	4.4	5.6	9.7	3.8	5.2	9.0
	Medium	(2) 1/5			8.2			3.0			2.4		
	Low	(2) 1/6			6.4			2.2			1.6		
18	High	(2) 1/4	(2) 1/3	2	9.8	10.0	17.3	4.4	5.6	9.7	3.8	5.2	9.0
	Medium	(2) 1/5			8.2			3.0			2.4		
	Low	(2) 1/6			6.4			2.2			1.6		
20	High	(2) 1/4	(2) 1/3	2	9.8	10.0	17.3	4.4	5.6	9.7	3.8	5.2	9.0
	Medium	(2) 1/5			8.2			3.0			2.4		
	Low	(2) 1/6			6.4			2.2			1.6		

NOTES: Motor electrical data is nameplate data. Actual data will vary with application. Motors name plated for 208-230/1/60. Data is at 230 volts. EC motors operated on 208/1/60 power result in reduced airflow.

AHRI STANDARD RATINGS

Model / Size	AHRI 440 Certified	Coil		Airflow CFM (Dry Flow)	Cooling Capacity		Water		Power Input (WATTS)
		Rows	FPI		QT (BTUH)	QS (BTUH)	Flow Rate GPM	WPD ft-wg	
KHG06	*	4	10	669	20299	15560	4	5.64	247
KHG08	*	4	10	950	25889	19389	5.2	8.03	375
KHG10	*	4	10	1001	30180	22420	6.1	6.87	457
KHG12	*	4	10	1437	44169	33509	8.8	6.68	494
KHG14		4	10	1906	51990	41159	10.4	5.01	750
KHG16		4	10	1852	56810	43029	11.3	6.4	914
KHG18		4	10	1915	62750	46369	12.4	8.18	914
KHG20		4	10	1999	68059	49580	13.6	10.06	914

NOTE: Based on 80°F DB and 67°F WB EAT, 45°F EWT, 10°F temperature rise, high fan speed. Motor type is PSC and motor voltage is 115/1/60. Airflow under dry coil conditions. All models tested at 0.05" external static pressure. Airflow rate CFM on sizes 14 through 20 exceed maximum ratings in AHRI 440 and are therefore not certified.

SECTION 3 - NORMAL OPERATION AND PERIODIC MAINTENANCE

CONTROLS OPERATION

Before proper control operation can be verified all other systems must be in proper operation. The correct water and air temperatures must be present for the control function being tested. Some controls and features are designed to not operate under certain conditions or beyond designed range.

A wide range of controls and electrical options and accessories may be used with the equipment covered in this manual. Consult the approved unit submittals, order acknowledgement, and other manuals for detailed information regarding each individual unit and its controls. Since controls and features may vary from one unit to another, care should be taken to identify the controls to be used on each unit and their proper control sequence. Information provided by component manufacturers regarding installation, operation, and maintenance of their individual controls is available upon request.

PHYSICAL DATA

Each unit on a job will have its own unique operating environment and conditions that may dictate a maintenance schedule for that unit that is different from other equipment on the job. A formal schedule of regular maintenance and an individual unit log should be established and maintained. This will help to achieve the maximum performance and service life of each unit on the job.

For more detailed information concerning service operations, consult your Sales Representative or the Factory.

MOTOR/BLOWER ASSEMBLY

The type of fan operation is determined by the control components and their method of wiring, and may vary from unit to unit. Refer to the wiring diagram for each unit for that unit's individual operating characteristics. Motors are permanently lubricated, PSC or ECM type and do not require field lubrication.

 **NOTE** - Information regarding safety precautions contained in the preface at the beginning of this manual should be followed during any service and maintenance operations.

FAN ASSEMBLY

Each fan assembly is easily removed from the unit at four 1/4" weld studs in the fan deck. In most applications the fan assembly can be removed without disconnecting the ductwork for service access to motors and blowers at, or away from the unit.

Should the assembly require more extensive service, the motor/blower assembly may be removed from the unit to facilitate such operations as motor or blower wheel/housing replacement, etc. Dirt and dust should not be allowed to accumulate on the blower wheel or housing. This can result in an unbalanced blower wheel condition that can damage a blower wheel or motor. The wheel and housing may be cleaned periodically using a vacuum cleaner and a brush taking care not to dislodge the factory balancing weights on the blower wheel blades.

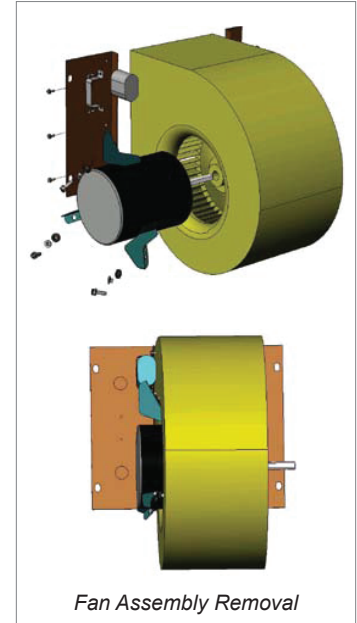

To remove the motor from the fan, disconnect the motor wire leads, loosen the set screw on the motor shaft and remove the (3) cap screws that attached the motor to the blower housing. To reassemble, insert the motor into the blower wheel, (motor slots to be facing up) center the blower wheel within the blower housing and tighten the set screw. Reinstall the (3) cap screws and tighten to 40 in/lbs. Place the entire fan assembly back up over the weld studs, install the washers and tighten the 1/4-20 nylok nuts to 65 in/lbs.

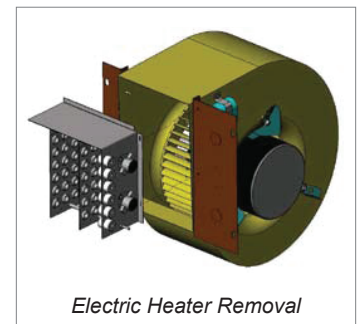

COIL

Coils may be cleaned in place by removing the motor/blower assemblies and brushing the entering air face between fins with a soft brush parallel to fins.

Do not brush perpendicular to fin orientation as damage may occur. Brushing should be followed by cleaning with a vacuum cleaner. If a compressed air source is available, the coil may also be cleaned by blowing air through the coil fins from the leaving air face. Vacuuming should again follow this. Units provided with the proper type of air filters, replaced regularly, may require periodic coil cleaning.

SECTION 3 - NORMAL OPERATION AND PERIODIC MAINTENANCE (CONT)

UNIT WEIGHTS

Component	Unit Size								
	06	08	10	12	14	16	18	20	
KHGH Base Unit	68 [31]	73 [33]	77 [35]	114 [52]	119 [54]	124 [56]	128 [58]	132 [60]	
KHGP Base Unit	87 [40]	95 [43]	101 [46]	141 [64]	150 [68]	157 [71]	164 [75]	170 [77]	
KHGP with Mixing Box	119 [54]	132 [60]	144 [65]	189 [86]	204 [93]	217 [99]	229 [104]	246 [112]	
KHGE Base Unit	137 [62]	146 [66]	158 [72]	202 [92]	219 [99]	228 [103]	240 [109]	250 [113]	
Coil Rows	1 Row - Dry	5 [2]	6 [3]	7 [3]	8 [4]	10 [5]	10 [5]	11 [5]	12 [5]
	1 Row - Wet	7 [3]	9 [4]	10 [5]	11 [5]	14 [6]	14 [6]	16 [7]	17 [8]
	2 Row - Dry	11 [5]	13 [6]	14 [6]	16 [7]	20 [9]	20 [9]	22 [10]	24 [11]
	2 Row - Wet	14 [6]	18 [8]	20 [9]	23 [10]	27 [12]	28 [13]	32 [15]	35 [16]
	3 Row - Dry	16 [7]	19 [9]	21 [10]	24 [11]	30 [13]	30 [14]	33 [15]	36 [16]
	3 Row - Wet	21 [10]	27 [12]	30 [14]	34 [15]	41 [19]	42 [19]	48 [22]	52 [24]
	4 Row - Dry	21 [10]	25 [12]	29 [13]	33 [15]	40 [18]	40 [18]	44 [20]	48 [22]
	4 Row - Wet	27 [12]	35 [16]	41 [19]	46 [21]	54 [25]	56 [25]	64 [29]	69 [31]
	5 Row - Dry	26 [12]	30 [14]	34 [16]	38 [17]	42 [19]	46 [21]	50 [23]	54 [25]
	5 Row - Wet	33 [15]	39 [18]	45 [21]	51 [23]	57 [26]	63 [29]	70 [32]	77 [35]
	6 Row - Dry	32 [15]	38 [17]	43 [19]	49 [22]	59 [27]	61 [28]	67 [30]	71 [32]
	6 Row - Wet	42 [19]	53 [24]	61 [28]	69 [31]	80 [36]	85 [39]	97 [44]	103 [47]
	7 Row - Dry	38 [17]	42 [19]	48 [22]	54 [25]	60 [28]	66 [30]	72 [33]	78 [35]
	7 Row - Wet	49 [23]	56 [26]	63 [29]	70 [32]	77 [35]	84 [38]	91 [42]	98 [45]
	8 Row - Dry	43 [20]	49 [22]	55 [25]	61 [28]	67 [30]	73 [33]	79 [36]	85 [39]
	8 Row - Wet	55 [26]	63 [29]	71 [32]	79 [36]	87 [40]	95 [43]	103 [47]	111 [50]

NOTE: Unit weight data is in pounds [kilograms].

ELECTRIC RESISTANCE HEATER ASSEMBLY

Electric resistance heaters typically require no normal periodic maintenance when unit air filters are changed properly. Other conditions and equipment may affect the operation and service life in the system. The two most important operating conditions for an electric heater are proper airflow and proper supply voltage. High supply voltage and/or poorly distributed or insufficient airflow over the element will result in element overheating. This condition may result in the heater cycling on the high limit thermal cutout. The open wire type heaters provided have an automatic reset switch with a back-up high limit thermal switch. Automatic reset switches are as the name implies; they reset automatically after the heater has cooled down. High limit thermal switches must be replaced once the circuit has been broken. The high limit thermal cutout device is a safety device only and is not intended for continuous operation. With proper unit application and during normal operation, the high limit thermal cutout will not operate. This device only operates when some problem exists and ANY condition that causes high limit cutout MUST be corrected immediately. High supply voltage also causes excessive amperage draw and may result in tripping of the circuit breaker or blowing of the fuses on the incoming power supply.

ELECTRICAL WIRING & CONTROLS

The electrical operation of each unit is determined by the components and wiring of the unit and may vary from unit to unit. Consult the wiring diagram for the actual type and number of controls provided on each unit. The integrity of all electrical connections should be verified at least twice during the first year of operation. Afterwards, all controls should be inspected regularly for proper operation. Some components may experience erratic operation or failure due to age. Wall thermostats may also become clogged with dust and lint and should be periodically inspected and cleaned to provide reliable operation.

When replacing any components such as fuses, contactors, or relays, use only the exact type, size, and voltage component as furnished from the factory. Any deviation without factory authorization could result in personnel injury or damage to the unit and will void all factory warranties. All repair work should be done in such a manner as to maintain the equipment in compliance with governing codes and ordinances or testing agency listings.

SECTION 3 - NORMAL OPERATION AND PERIODIC MAINTENANCE (CONT)

ELECTRICAL CALCULATIONS INFORMATION

1. Calculate FLA = [(Motor Amps)*(Motor Qty) + (Heater Amps)]
2. Calculate MCA = [(1.25)*(FLA)]
3. Calculate MOP = [(2.25)*(1st Motor Amps) + (2nd Motor Amps) + (Heater Amps)]
 - a. If the calculated MOP is within 10% of the next smaller available fuse size, that fuse size shall be used. If the calculated MOP is not within 10% of the next smaller available fuse size, the next larger fuse size above the calculated MOP must be used.
 - b. If the selected MOP is smaller than the MCA, the selected MOP must be increased to the next larger available fuse size above the MCA.
4. Non-Fused Door Interlock Disconnect Switch shall be sized according to MCA.
5. Fused Door Interlock Disconnect Switch and Main Fusing shall be sized according to MOP.

Available fuse sizes: 15, 20, 25, 30, 35, 40, 45, 50, 60, 70, 80 and 90.

MCA and MOP calculations are based on requirements from ANSI UL 1995 2nd Edition – CAN/CSA C22.2 No. 236-M90 Standard for Safety; Heating and Cooling Equipment, which incorporates rules from NFPA 70 National Electric Code 2002 edition.

ELECTRIC HEAT SELECTION CHART

Unit Size	MBH	6.8	8.5	10.2	11.9	13.7	17.1	20.5	23.9	27.3	30.7	34.1	41.0	47.8
	kW	2.0	2.5	3.0	3.5	4.0	5.0	6.0	7.0	8.0	9.0	10.0	12.0	14.0
	VOLTS	AMPS												
06	115	17.4	21.7	26.1	30.4	34.8	-	-	-	-	-	-	-	-
	208	9.6	12.0	14.4	16.8	19.2	-	-	-	-	-	-	-	-
	230	8.7	10.9	13.0	15.2	17.4	-	-	-	-	-	-	-	-
	277	7.2	9.0	10.8	12.6	14.4	-	-	-	-	-	-	-	-
08	115	17.4	21.7	26.1	30.4	34.8	43.5	-	-	-	-	-	-	-
	208	9.6	12.0	14.4	16.8	19.2	24.0	28.8	-	-	-	-	-	-
	230	8.7	10.9	13.0	15.2	17.4	21.7	26.1	-	-	-	-	-	-
	277	7.2	9.0	10.8	12.6	14.4	18.1	21.7	-	-	-	-	-	-
10	115	17.4	21.7	26.1	30.4	34.8	43.5	-	-	-	-	-	-	-
	208	9.6	12.0	14.4	16.8	19.2	24.0	28.8	33.7	-	-	-	-	-
	230	8.7	10.9	13.0	15.2	17.4	21.7	26.1	30.4	-	-	-	-	-
	277	7.2	9.0	10.8	12.6	14.4	18.1	21.7	25.3	-	-	-	-	-
12	115	-	-	-	-	34.8	43.5	-	-	-	-	-	-	-
	208	-	-	-	-	19.2	24.0	28.8	33.7	38.5	43.3	-	-	-
	230	-	-	-	-	17.4	21.7	26.1	30.4	34.8	39.1	-	-	-
	277	-	-	-	-	14.4	18.1	21.7	25.3	28.9	32.5	-	-	-
14	115	-	-	-	-	34.8	43.5	-	-	-	-	-	-	-
	208	-	-	-	-	19.2	24.0	28.8	33.7	38.5	43.3	48.1	-	-
	230	-	-	-	-	17.4	21.7	26.1	30.4	34.8	39.1	43.5	-	-
	277	-	-	-	-	14.4	18.1	21.7	25.3	28.9	32.5	36.1	-	-
16	115	-	-	-	-	34.8	43.5	-	-	-	-	-	-	-
	208	-	-	-	-	19.2	24.0	28.8	33.7	38.5	43.3	48.1	57.7	-
	230	-	-	-	-	17.4	21.7	26.1	30.4	34.8	39.1	43.5	52.2	-
	277	-	-	-	-	14.4	18.1	21.7	25.3	28.9	32.5	36.1	43.3	-
18	115	-	-	-	-	34.8	43.5	-	-	-	-	-	-	-
	208	-	-	-	-	19.2	24.0	28.8	33.7	38.5	43.3	48.1	57.7	-
	230	-	-	-	-	17.4	21.7	26.1	30.4	34.8	39.1	43.5	52.2	-
	277	-	-	-	-	14.4	18.1	21.7	25.3	28.9	32.5	36.1	43.3	-
20	115	-	-	-	-	34.8	43.5	-	-	-	-	-	-	-
	208	-	-	-	-	19.2	24.0	28.8	33.7	38.5	43.3	48.1	57.7	67.3
	230	-	-	-	-	17.4	21.7	26.1	30.4	34.8	39.1	43.5	52.2	60.9
	277	-	-	-	-	14.4	18.1	21.7	25.3	28.9	32.5	36.1	43.3	50.5

NOTES: Dash (-) areas indicate kW and voltage options not available. Available voltages are single phase, 60 hertz. Heaters over 48 AMPS are subdivided and fused per NEC.

SECTION 3 - NORMAL OPERATION AND PERIODIC MAINTENANCE (CONT)

VALVES & PIPING

No formal maintenance is required on the valve package components most commonly used with fan coil units other than a visual inspection for possible leaks in the course of other normal periodic maintenance. In the event that a valve should need replacement, the same precautions taken during the initial installation to protect the valve package from excessive heat should also be used during replacement. In some cases, the valve actuator may fail and usually can be replaced without removing valve body from piping.

DRAIN

The drain should be checked before initial start-up and at the beginning of each cooling season to assure that the lines are clear. If it is clogged, steps should be taken to clear the debris so that condensate will flow easily. Periodic checks of the drain should be made during the cooling season to maintain a free flowing condensate. Should the growth of algae and/or bacteria be a concern, consult an air conditioning and refrigeration supply organization familiar with local conditions for chemicals available to control these agents.

FILTERS

This unit is equipped with a standard 1" throwaway filter most commonly used on fan coil units should be replaced on a regular basis. The time interval between each replacement should be established based on regular inspection of the filter and should be recorded in the log for each unit. At a minimum, filters should be inspected monthly and replaced if needed. Refer to the Filters chart for recommended filter size for each product type and size. If the replacement filters are not purchased from the factory, the filters used should be the same type, size and

MERV rating as that furnished from or recommended by the factory. Optional 1" and 2" pleated filters are available and can be used in this unit. Contact the local Sales Representative for the correct filter upgrade specification and availability. Consult the factory for applications using filter types other than the factory standard or optional product.

FILTER REPLACEMENT

To replace the filter(s), unscrew the thumb screws located at the bottom of the filter bracket a few turns until the filter tray freely slides out. Slide out the used filter(s) and replace with the new one(s). Reattach the filter tray to the filter bracket with the supplied thumb screws.



NOTE - The filter tray is fully adjustable and can be rotated 180 degrees if necessary to ensure a snug fit between the filter and the filter bracket.



FACE AREA, FREE AREA AND FILTER SIZES

Unit Size	Coil Face Area	Nominal Filter Sizes	1" Throwaway Face Area	1" Pleated Gross Media Area	2" Pleated Gross Media Area
06	1.56 [0.15]	(Qty 1) 16" x 16" (406 x 406)	1.62 [0.15]	4.0 [0.37]	5.4 [0.50]
08	2.08 [0.19]	(Qty 1) 16" x 20" (406 x 508)	2.04 [0.19]	4.8 [0.45]	6.8 [0.63]
10	2.50 [0.23]	(Qty 1) 16" x 25" (406 x 381)	2.57 [0.24]	6.0 [0.56]	8.5 [0.79]
12	3.02 [0.28]	(Qty 2) 16" x 16" (406 x 406)	3.23 [0.30]	8.0 [0.74]	10.4 [0.97]
14	3.54 [0.33]	(Qty 1) 16" x 16" -- and -- (Qty 1) 16" x 20" (Qty 1) (406 x 406) -- and -- (Qty 1) (406 x 508)	3.65 [0.34]	8.8 [0.82]	12.2 [1.13]
16	4.06 [0.38]	(Qty 2) 16" x 20" (406 x 508)	4.08 [0.38]	9.6 [0.89]	13.4 [1.24]
18	4.58 [0.43]	(Qty 1) 16" x 20" -- and -- (Qty 1) 16" x 25" (Qty 1) (406 x 508) -- and -- (Qty 1) (406 x 635)	4.61 [0.43]	10.8 [1.00]	14.3 [1.33]
20	5.00 [0.46]	(Qty 2) 16" x 25" (406 x 635)	5.14 [0.48]	12.0 [1.11]	17.0 [1.58]

NOTES: Face and free areas are in square feet [square meters]. Filter sizes are in inches (millimeters).

SECTION 3 - NORMAL OPERATION AND PERIODIC MAINTENANCE (CONT)

REPLACEMENT PARTS

Factory replacement parts should be used wherever possible to maintain the unit performance and operating characteristics and the testing agency listings. Replacement parts may be purchased through the local Sales Representative.

Contact the local Sales Representative before attempting any unit modifications. Any modifications not authorized by the factory could result in personal injury and damage to the unit and could void all factory warranties.

When ordering parts, the following information must be supplied to ensure proper part identification:

1. Complete unit model number
2. Unit hand connection (right or left hand) while facing the direction of airflow at the inlet
3. Complete part description including any numbers

On warranty replacements, in addition to the information previously listed, the project CO # that appears on the unit nameplate, is required. Contact the factory for authorization to return any parts such as defective parts replaced in warranty. All shipments returned to the factory MUST be marked with a Return Authorization Number, which is provided by the factory.

All equipment and components sold through Krueger are warranted under the same conditions as the standard manufacturer's warranty with the exception that the warranty period is 12 months unless the component is furnished as warranty replacement. Parts furnished as warranty replacements are warranted for the remaining term of the original unit warranties.

SECTION 3 - NORMAL OPERATION AND PERIODIC MAINTENANCE (CONT)

KHGH TOP AND SIDE VIEWS

DIMENSIONAL REFERENCES

Coil Rows	Coil Circ.	X
1*	1	0.00" (0)
1	2	1.08" (55)
2	Any	1.08" (55)
3	Any	2.17" (82)
4	Any	3.25" (110)
6	Any	5.42" (165)

**NOTE: 1 Row single circuit coils are on the same axis, but are 13 3/4" apart in height.*

KHGH CONTROL ENCLOSURE SIZES

10 x 16 x 6 (250 x 406 x 152)
16 x 16 x 6 (406 x 406 x 152)

NOTE: Control enclosure size is determined by electrical components selected.

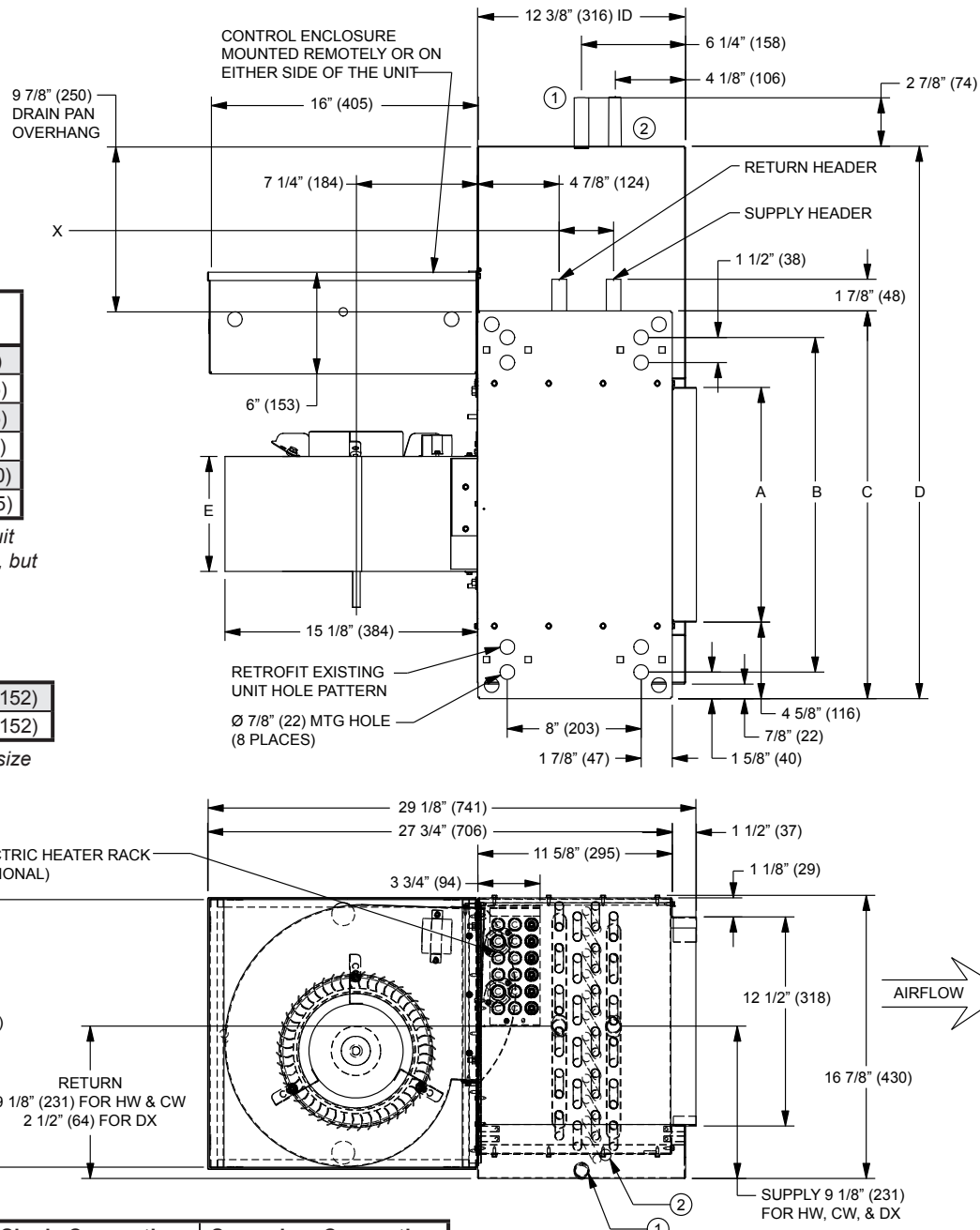

9 7/8" (250) DRAIN PAN OVERHANG
 CONTROL ENCLOSURE MOUNTED REMOTELY OR ON EITHER SIDE OF THE UNIT
 12 3/8" (316) ID
 6 1/4" (158)
 4 1/8" (106)
 2 7/8" (74)
 16" (405)
 7 1/4" (184)
 4 7/8" (124)
 RETURN HEADER
 SUPPLY HEADER
 1 1/2" (38)
 1 7/8" (48)
 6" (153)
 15 1/8" (384)
 RETROFIT EXISTING UNIT HOLE PATTERN
 Ø 7/8" (22) MTG HOLE (8 PLACES)
 8" (203)
 1 7/8" (47)
 4 5/8" (116)
 7/8" (22)
 1 5/8" (40)
 29 1/8" (741)
 27 3/4" (706)
 1 1/2" (37)
 11 5/8" (295)
 1 1/8" (29)
 3 3/4" (94)
 12 1/2" (318)
 16 7/8" (430)
 AIRFLOW
 RETURN 9 1/8" (231) FOR HW & CW
 2 1/2" (64) FOR DX
 SUPPLY 9 1/8" (231) FOR HW, CW, & DX

Drain Pan Material	Single Connection (STD) ①	Secondary Connection (OPTIONAL) ②
Galvanized (STD)	7/8" OD Copper	5/8" OD Copper
Stainless (OPT)	3/4" MPT Galv.	1/2" MPT Galv.

NOTES: All dimensions are in inches (millimeters) and are +/- 1/8". See next page for specific unit dimensions, options and specifications. It is recommended to provide 3' access on pipe connection side. Provide access clearance for electrical enclosure per local and national electrical code requirements.

SECTION 3 - NORMAL OPERATION AND PERIODIC MAINTENANCE (CONT)

KHGH ISOMETRIC AND SIDE VIEWS

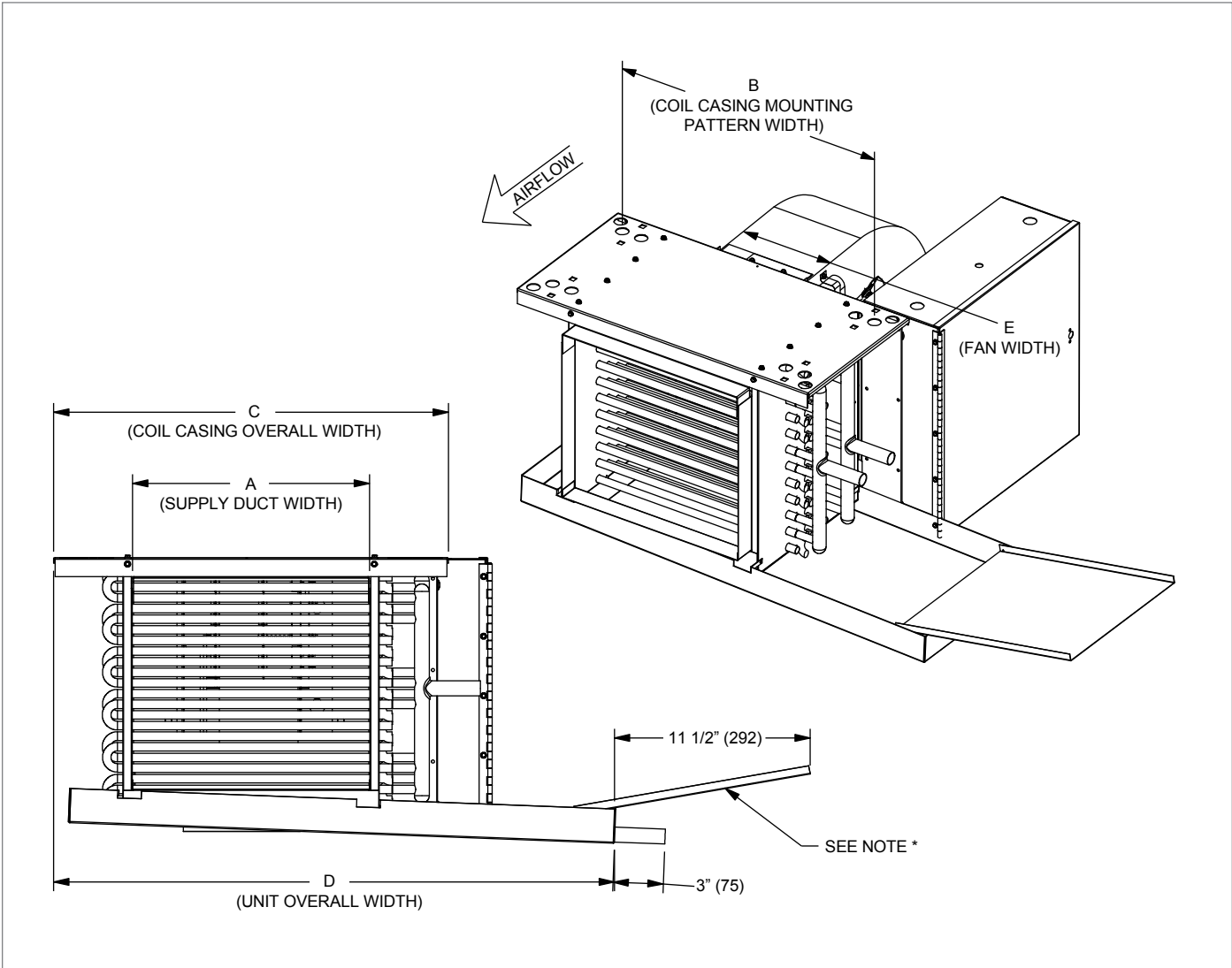

DIMENSIONAL REFERENCES

Unit Size	Fan Quantity	A	B	C	D	E
6	1	14" (356)	20" (508)	23 1/8" (587)	34" (864)	6 7/8" (175)
8	1	19" (483)	25" (635)	28 1/8" (714)	39" (991)	8 1/4" (210)
10	1	23" (584)	29" (737)	32 1/8" (816)	43" (1092)	8 1/4" (210)
12	2	28" (711)	34" (864)	37 1/8" (943)	48" (1219)	6 7/8" (175)
14	2	33" (838)	39" (991)	42 1/8" (1070)	53" (1346)	8 1/4" (210)
16	2	38" (965)	44" (1118)	47 1/8" (1197)	58" (1473)	8 1/4" (210)
18	2	43" (1092)	49" (1245)	52 1/8" (1324)	63" (1600)	8 1/4" (210)
20	2	47" (1194)	53" (1346)	56 1/8" (1426)	67" (1702)	8 1/4" (210)

NOTES: All dimensions are in inches (millimeters) and are +/- 1/8". Drain pan is field reversible 180° and externally insulated. Coil hand is field reversible (left hand unit shown).

* Optional auxiliary drip pan available for piping package condensate.

SECTION 3 - NORMAL OPERATION AND PERIODIC MAINTENANCE (CONT)

KHGP TOP AND SIDE VIEWS

DIMENSIONAL REFERENCES

Coil Rows	Coil Circ.	X
1*	1	0.00" (0)
1	2	1.08" (55)
2	Any	1.08" (55)
3	Any	2.17" (82)
4	Any	3.25" (110)
6	Any	5.42" (165)

*NOTE: 1 Row single circuit coils are on the same axis, but are 13 3/4" apart in height.

KHGP CONTROL ENCLOSURE SIZES

10 x 16 x 6 (250 x 406 x 152)
16 x 16 x 6 (406 x 406 x 152)

NOTE: Control enclosure size is determined by electrical components selected.

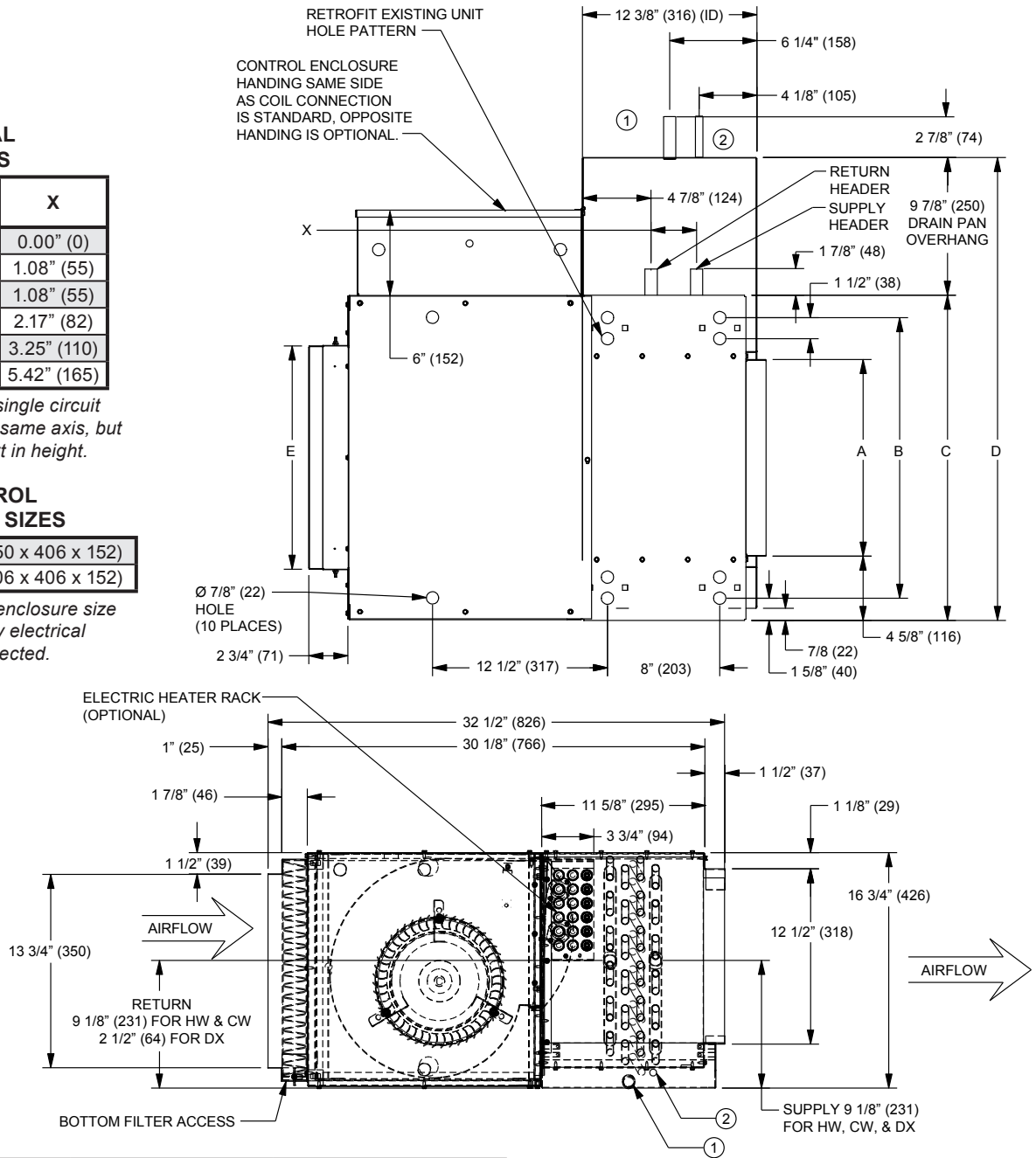

Drain Pan Material	Single Connection (STD) ①	Secondary Connection (OPTIONAL) ②
Galvanized (STD)	7/8" OD Copper	5/8" OD Copper
Stainless (OPT)	3/4" MPT Galv.	1/2" MPT Galv.

NOTES: All dimensions are in inches (millimeters) and are +/- 1/8". See next page for specific unit dimensions, options and specifications. It is recommended to provide 3' access on pipe connection side. Provide access clearance for electrical enclosure per local and national electrical code requirements.

SECTION 3 - NORMAL OPERATION AND PERIODIC MAINTENANCE (CONT)

KHGP ISOMETRIC AND SIDE VIEWS

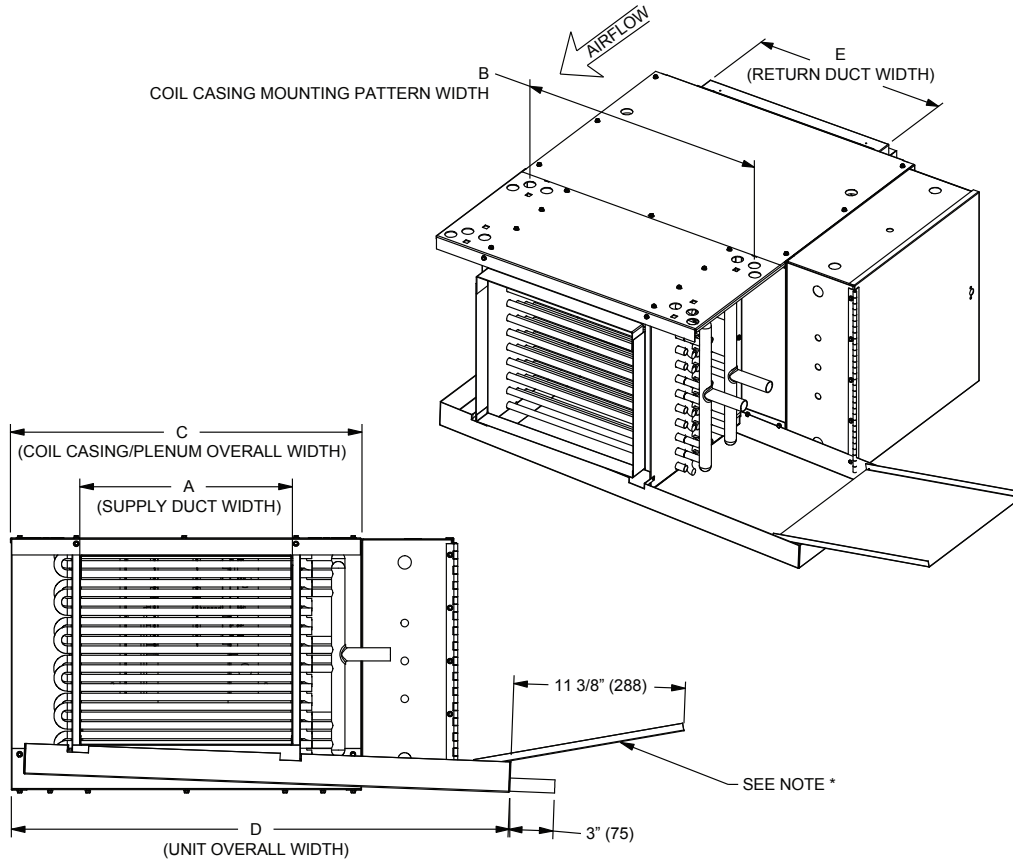

DIMENSIONAL REFERENCES

Unit Size	Fan Quantity	A	B	C	D	E
6	1	14" (356)	20" (508)	23 1/8" (587)	34" (864)	16" (406)
8	1	19" (483)	25" (635)	28 1/8" (714)	39" (991)	19 7/8" (505)
10	1	23" (584)	29" (737)	32 1/8" (816)	43" (1092)	25 7/8" (657)
12	2	28" (711)	34" (864)	37 1/8" (943)	48" (1219)	32" (813)
14	2	33" (838)	39" (991)	42 1/8" (1070)	53" (1346)	35 7/8" (911)
16	2	38" (965)	44" (1118)	47 1/8" (1197)	58" (1473)	39 7/8" (1013)
18	2	43" (1092)	49" (1245)	52 1/8" (1324)	63" (1600)	44 7/8" (1140)
20	2	47" (1194)	53" (1346)	56 1/8" (1426)	67" (1702)	49 7/8" (1267)

NOTES: All dimensions are in inches (millimeters) and are +/- 1/8". Drain pan is field reversible 180° and externally insulated. Coil hand is field reversible (left hand unit shown). Plenum box is field reversible for rear or bottom return air. Filter rack can accommodate standard 1" TAW and 1" and 2" pleated filters.

* Optional auxiliary drip pan available for piping package condensate.

SECTION 3 - NORMAL OPERATION AND PERIODIC MAINTENANCE (CONT)

KHGP WITH MIXING BOX TOP AND SIDE VIEWS

DIMENSIONAL REFERENCES

Unit Size	A	B	C	D
6	23 1/8" (587)	20" (508)	12 5/8" (321)	14" (356)
8	28 1/8" (714)	25" (635)	16 5/8" (422)	19" (483)
10	32 1/8" (816)	29" (737)	20 5/8" (524)	23" (584)
12	37 1/8" (943)	34" (864)	24 5/8" (625)	28" (711)
14	42 1/8" (1070)	39" (991)	28 5/8" (727)	33" (838)
16	47 1/8" (1197)	44" (1118)	32 5/8" (829)	38" (965)
18	52 1/8" (1324)	49" (1245)	36 5/8" (930)	43" (1092)
20	56 1/8" (1426)	53" (1346)	40 5/8" (1032)	47" (1194)

KHGP CONTROL ENCLOSURE SIZES

10 x 16 x 6 (250 x 406 x 152)
16 x 16 x 6 (406 x 406 x 152)

NOTE: Control enclosure size is determined by electrical components selected.

NOTES: All dimensions are in inches (millimeters) and are +/- 1/8". The mixing box is field reversible from bottom to top and rear return. It is recommended to provide 3' access on pipe connection side. Provide access clearance for electrical enclosure per local and national electrical code requirements. Mixing box side panels are removable for access to the linkage / actuator.

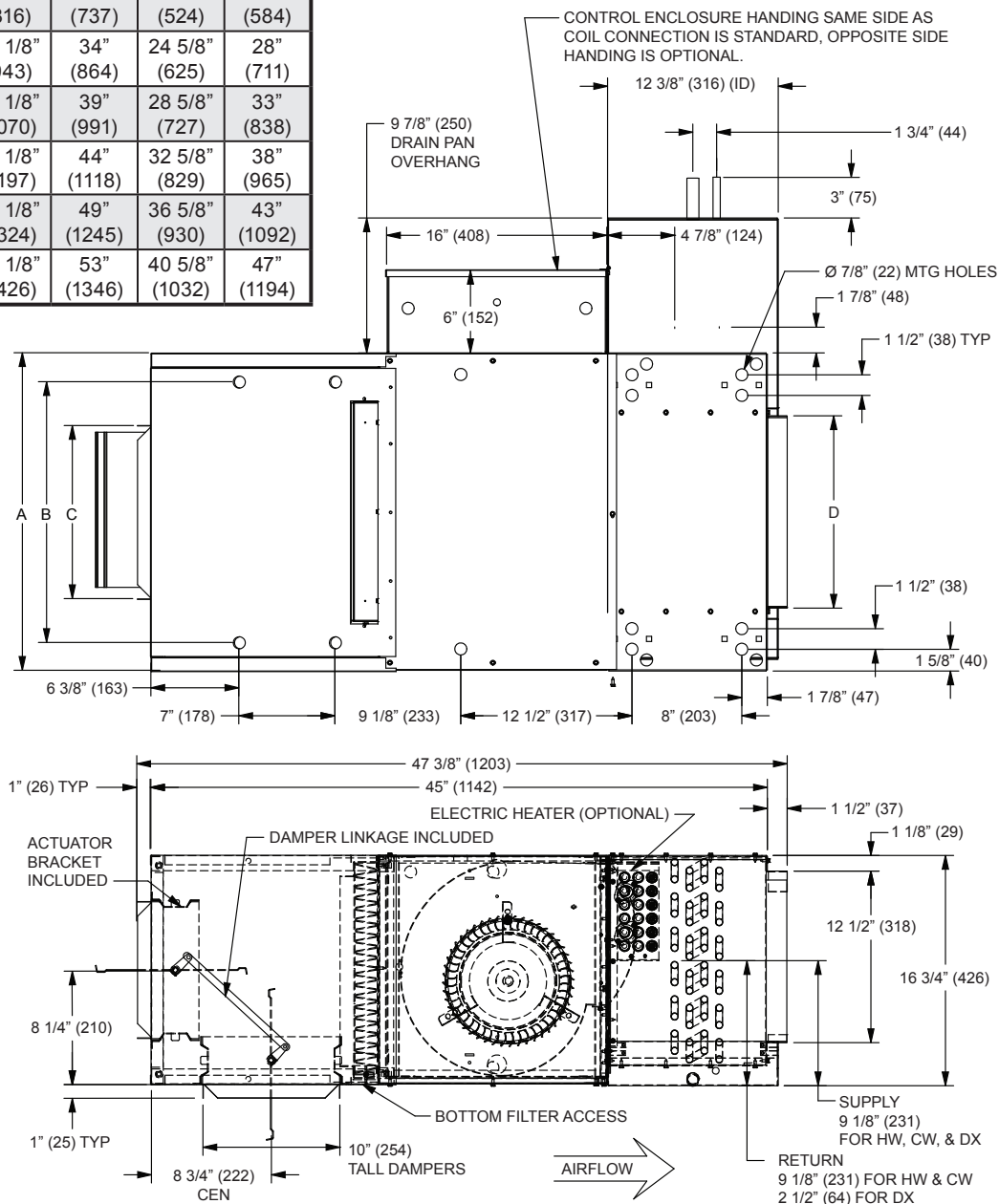

SECTION 3 - NORMAL OPERATION AND PERIODIC MAINTENANCE (CONT)

KHGE ISOMETRIC VIEWS

Unit Size	A	B	C	D
6	13 1/2" (343)	31 1/4" (794)	20" (508)	15 1/2" (394)
8	18 1/2" (470)	36 1/4" (921)	25" (635)	19 1/2" (495)
10	22 1/2" (572)	40 1/4" (1022)	29" (737)	24 1/2" (622)
12	27 1/2" (699)	45 1/4" (1149)	34" (864)	31 1/2" (800)
14	32 1/2" (826)	50 1/4" (1276)	39" (991)	35 1/2" (902)
16	37 1/2" (953)	55 1/4" (1403)	44" (1118)	39 1/2" (1003)
18	42 1/2" (1080)	60 1/4" (1530)	49" (1245)	44 1/2" (1130)
20	46 1/2" (1181)	64 1/4" (1632)	53" (1346)	49 1/2" (1257)

REAR RETURN UNIT

BOTTOM RETURN UNIT

REAR RETURN UNIT

BOTTOM RETURN UNIT

NOTES: All dimensions are in inches (millimeters) and are +/- 1/8". Internal hinged electrical enclosure not shown. Optional 1" or 2" pleated filters available (shown) standard 1" throwaway filter not shown. 1 1/4" duct collar standard on all ducted units. It is recommended to provide 3' access on pipe connection side. Provide access clearance for electrical enclosure per local and national electrical code requirements.

KHGE CONTROL ENCLOSURE SIZES

10 x 16 x 6 (250 x 406 x 152)
10 x 20 x 6 (250 x 500 x 152)

NOTE: Control enclosure size is determined by electrical components selected.

SECTION 3 - NORMAL OPERATION AND PERIODIC MAINTENANCE (CONT)

KHG SERIES TELESCOPING / FILTER AND SOLID BOTTOM ACCESS PANELS

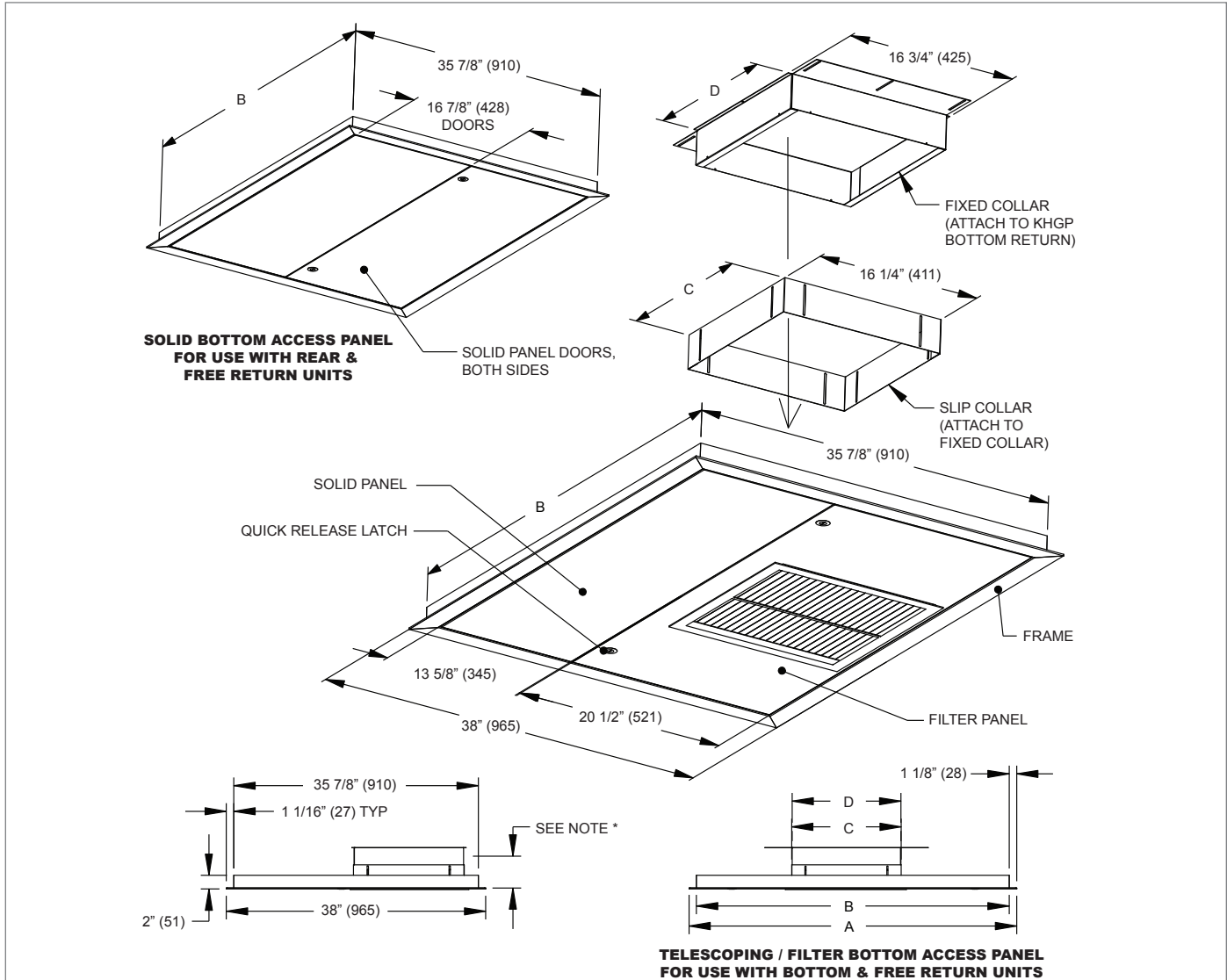

KHG SERIES TELESCOPING / FILTER AND SOLID BOTTOM ACCESS PANELS DIMENSIONAL REFERENCES

Unit Size	A	B	C	D	Recommended Ceiling Cutout
6	48" (1219)	45 7/8" (1164)	16" (408)	15 7/8" (404)	46 1/8" x 36 1/8" (1171 x 918)
8	53" (1346)	50 7/8" (1291)	20" (509)	19 7/8" (506)	51 1/8" x 36 1/8" (1298 x 918)
10	57" (1448)	54 7/8" (1392)	25" (636)	24 7/8" (633)	55 1/8" x 36 1/8" (1400 x 918)
12	62" (1575)	59 7/8" (1519)	32" (814)	31 7/8" (811)	60 1/8" x 36 1/8" (1527 x 918)
14	67" (1702)	64 7/8" (1646)	36" (916)	35 7/8" (912)	65 1/8" x 36 1/8" (1654 x 918)
16	72" (1829)	69 7/8" (1773)	40" (1017)	39 7/8" (1014)	70 1/8" x 36 1/8" (1781 x 918)
18	77" (1956)	74 7/8" (1900)	45" (1144)	44 7/8" (1141)	75 1/8" x 36 1/8" (1908 x 918)
20	81" (2057)	78 7/8" (2002)	50" (1271)	49 7/8" (1268)	79 1/8" x 36 1/8" (2009 x 918)

NOTES: All dimensions are in inches (millimeters) and are +/- 1/8". 1" TAW filter standard, 1" or 2" pleated filters are optional. Bottom panels are removable. Filter and grille sizes are the same for each unit size in the KHG product line.
* Total telescoping adjustment is 3 1/2" to 6 1/2".

SECTION 3 - NORMAL OPERATION AND PERIODIC MAINTENANCE (CONT)

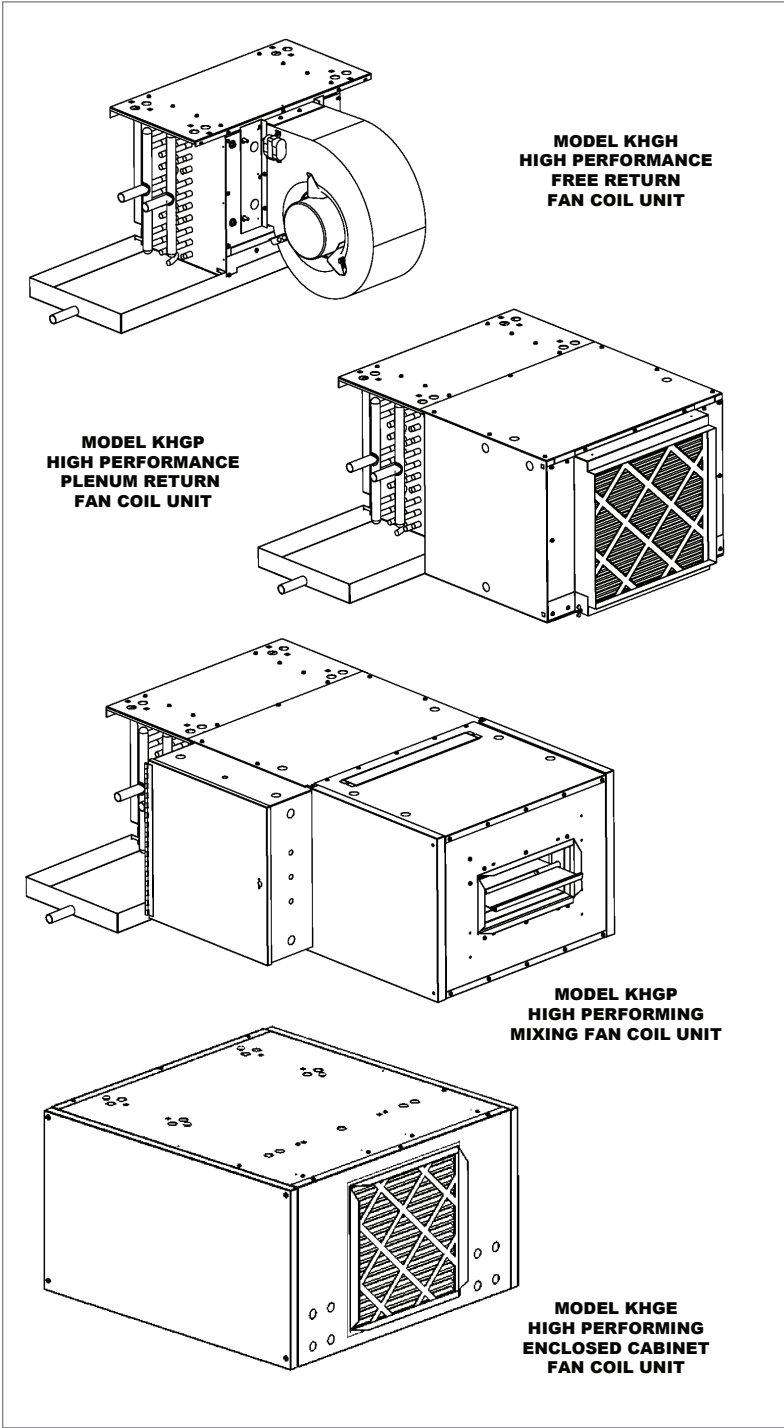

NOTES: All dimensions are in inches [mm] and are +/- 1/8". Coil handing is field reversible (left hand units shown).

COIL CONNECTION SIZES

Unit Size	A	C	D
06	HW	1	5/8
06	HW	2	5/8
06	HW	3	7/8
06	CW	3	7/8
06	HW	4	7/8
06	CW	4	7/8
06	CW	6	7/8
08	HW	1	5/8
08	HW	2	5/8
08	HW	3	7/8
08	CW	3	7/8
08	HW	4	7/8
08	CW	4	7/8
08	CW	6	7/8
10	HW	1	5/8
10	HW	2	5/8
10	HW	3	7/8
10	CW	3	7/8
10	HW	4	7/8
10	CW	4	7/8
10	CW	6	7/8
12	HW	1	5/8
12	HW	2	7/8
12	HW	3	7/8
12	CW	3	7/8
12	HW	4	7/8
12	CW	4	7/8
12	CW	6	1 1/8
14	HW	1	5/8
14	HW	2	7/8
14	HW	3	7/8
14	CW	3	7/8
14	HW	4	1 1/8
14	CW	4	1 1/8
14	CW	6	1 1/8
16	HW	1	5/8
16	HW	2	7/8
16	HW	3	7/8
16	CW	3	7/8
16	HW	4	1 1/8
16	CW	4	1 1/8
16	CW	6	1 1/8
18	HW	1	5/8
18	HW	2	7/8
18	HW	3	7/8
18	CW	3	1 1/8
18	HW	4	1 1/8
18	CW	4	1 1/8
18	CW	6	1 1/8
20	HW	1	5/8
20	HW	2	7/8
20	HW	3	1 1/8
20	CW	3	1 1/8
20	HW	4	1 1/8
20	CW	4	1 1/8
20	CW	6	1 1/8

SECTION 3 - NORMAL OPERATION AND PERIODIC MAINTENANCE (CONT)

ECM MOTOR BALANCING INSTRUCTIONS

COMMISSIONING

1. Verify that there is 22 to 28 V AC across terminals 15 and 16.
2. Verify that there is 15 VDC across terminals G (+) and COM (-).

MANUAL BALANCING

1. Verify that the jumper is in the "MAN" position (shipped from factory in Manual mode)
2. Connect voltmeter to wire loop VDC (+) and wire loop COM (-).
3. Determine the DC voltage for required airflow from the Fan Calibration Curve shown in Figure 2 and supplied on the side of the equipment. Use the bottom (5 to 10 volts DC) scale on the chart.
4. Using a 1/8" flat bladed screwdriver, adjust the manual speed potentiometer, labeled SPD, to obtain the required voltage. Clockwise increases airflow, counterclockwise decreases airflow.
5. Do not set the voltage lower than 5.1 VDC or higher than 9.9 VDC or motor may experience starting problems.
6. Do not set the balance voltage outside limits of the voltage/CFM curve or erratic motor operation and eventual failure may result.

REMOTE BALANCING

1. Relocate the jumper into the REM position.
2. Determine the DC voltage for required airflow from the Fan Calibration Curve supplied on the side of the equipment. Use the top (2 to 10 Analog Input Volts DC) scale on the chart.
3. Remotely adjust the external voltage source to the desired volts DC for required airflow.
4. Do not operate motor at control voltage lower than 2.1 VDC or higher than 9.9 VDC or motor may experience starting problems.
5. Do not set the balance voltage outside limits of the voltage/CFM curve or erratic motor operation, and eventual failure may result.

STATUS LED

When the motor is running, the LED alternates between CFM and RPM indications. In the RPM mode, LED turns on for a period of approximately 220 microseconds at a rate of 36 pulses per revolution. This mode lasts for ten seconds. Due to the rapid rate, LED will appear to be dimly lit, not flashing. As RPM is increased, brightness will increase. In the CFM mode, the LED will flash slowly, and at maximum brightness, once for every 100 CFM. Accuracy is +/- one flash. LED will then return to RPM mode, and cycle will repeat.

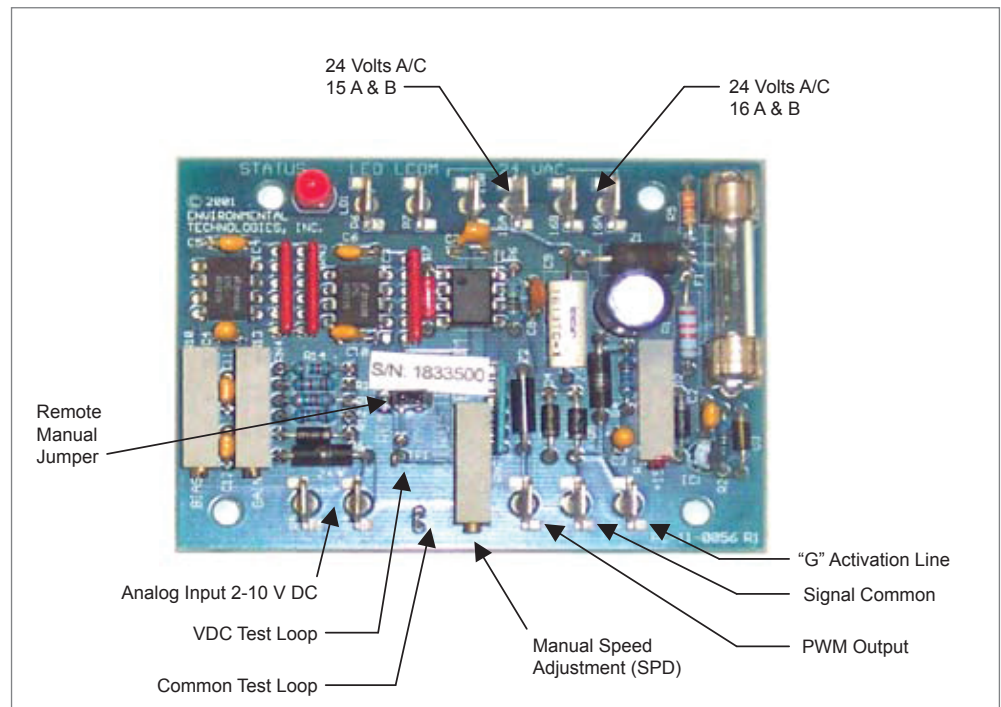

SECTION 3 - NORMAL OPERATION AND PERIODIC MAINTENANCE (CONT)

FAN CALIBRATION WITH ECM MOTOR

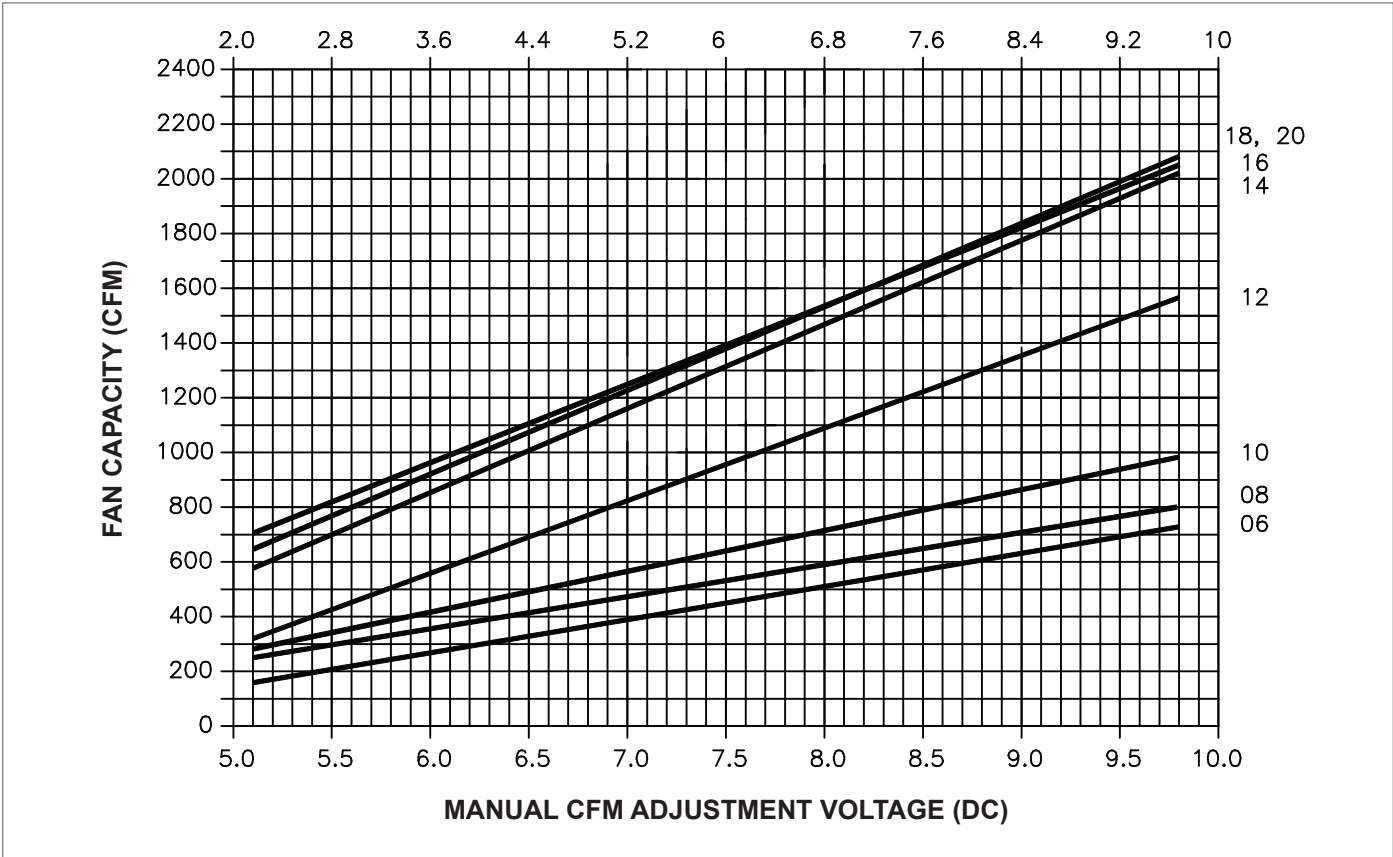

NOTES:

MANUAL BALANCING - Do not set the manual CFM adjustment voltage lower than 5.1 VDC or higher than 9.9 VDC.

REMOTE BALANCING - Do not set remote CFM adjustment voltage lower than 2.1 VDC or higher than 9.9 VDC.

WARNING - Input voltages which are less than or greater than the limits defined above may cause erratic motor operation and eventual failure.

SECTION 3 - NORMAL OPERATION AND PERIODIC MAINTENANCE (CONT)

ECM SPECIFIC TROUBLESHOOTING GUIDELINES

PROBLEM	POSSIBLE CAUSE	CORRECTIVE ACTION
Motor Fails to Start	CFM Adjustment voltage above 9.9 VDC or below 5.1 VDC.	Properly adjust CFM voltage.
	ECM cables improperly seated at motor.	Unplug cables from motor and re-install, making sure plugs on cables are fully seated in motor receptacles.
	ECM cables open or intermittent.	Replace cable(s). See section on checking cables below.
	Mechanical failure.	Check motor and confirm it rotates freely.
	Electrical failure.	Replace motor.
	Fan relay contacts oxidized/sulfidized.	Replace fan relay.
Motor Surges	Fan CFM adjustment voltage outside range of fan calibration curve.	Adjust voltage to value within range of fan calibration curve.
	ESP (external static pressure) too high.	Verify no discharge obstructions and coil fins are free of debris. Verify plenum opening is unobstructed. Verify filter (if supplied) is not dirty and does not obstruct flow of plenum air.
Excessive Motor Noise	Motor mounting bolts loose.	Tighten motor mounting bolts.
	Fan wheel rubbing on fan housing.	Align wheel in housing.
	Loose fan wheel.	Align and tighten.
Poor Performance	Lack of required external static pressure.	Add required external static pressure.
	Wrong program.	Contact factory.
Motor Runs in Reverse, Doesn't Respond to Speed Adjustment	Motor Failure.	Replace.

CHECKING ECM CABLES

Remove power from the unit. Unplug signal cable at motor, but leave quick connects attached to ETPWM board and fan relay or quick connect terminal block (see Figure 3 and 4). Use ohmmeter to check continuity. Repeat process for three wire power cable if signal cable does not appear to be defective (see Figure 3 and 5).



NOTE - Only very light force is required when inserting meter probe into plug. Excess force will damage contacts.

FIGURE 3

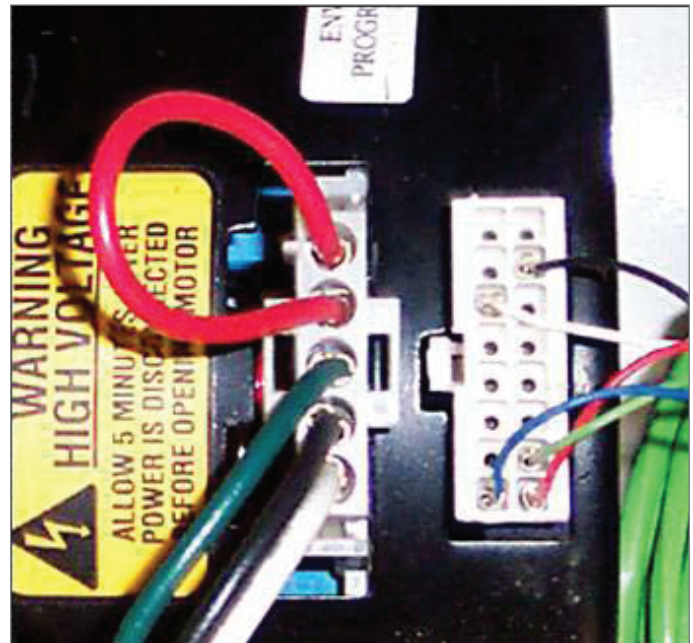

SECTION 3 - NORMAL OPERATION AND PERIODIC MAINTENANCE (CONT)

FIGURE 4

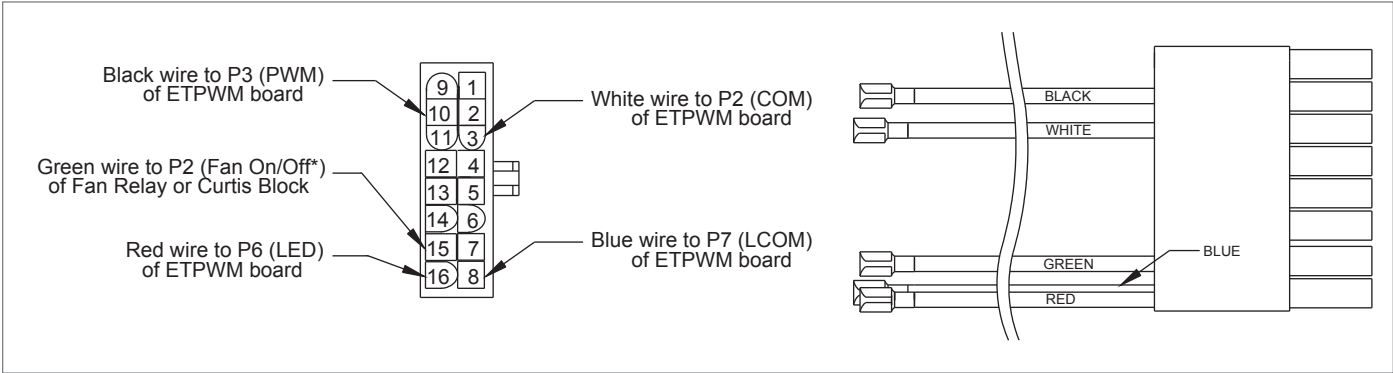
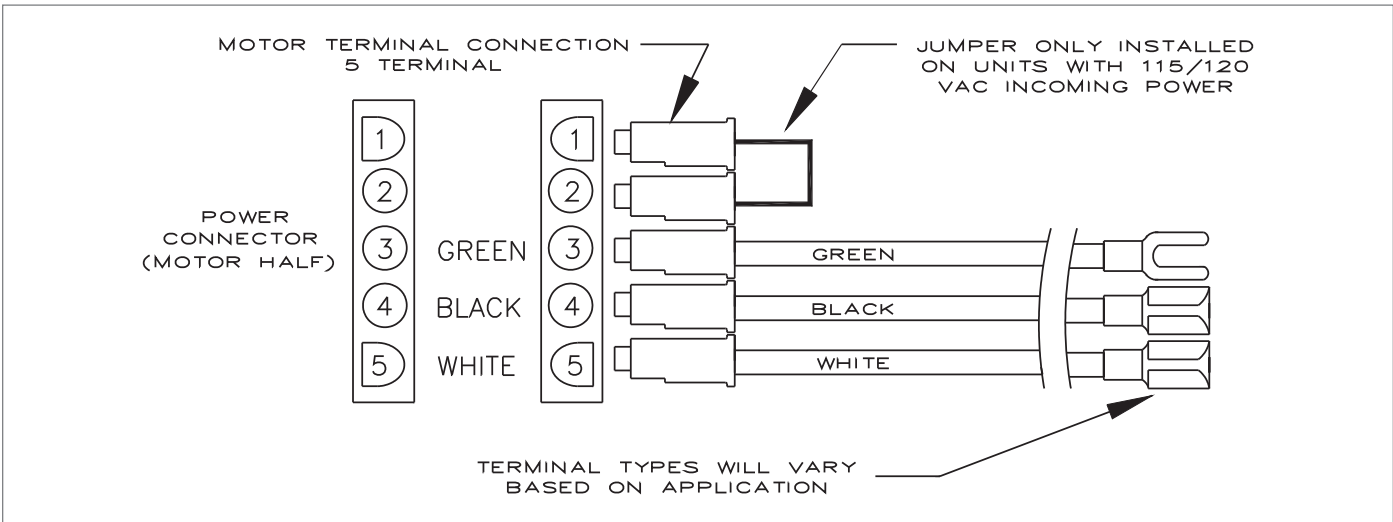

FIGURE 5



SECTION 3 - NORMAL OPERATION AND PERIODIC MAINTENANCE (CONT)

TROUBLESHOOTING GUIDE FOR FAN COIL RELAY BOARD

Ensure no wires are floating loosely in product. Verify all wires are connected properly on relay board.



NOTE - Motor power can only be connected to one voltage.

- P7- P6 = 115V
- P8- P6 = 208V
- P9- P6 = 230V
- P10- P6 = 277V

- Measure input voltage on relay board as indicated below:
 - » P1- P2 = 115V
 - » P1- P3 = 208V
 - » P1- P4 = 230V
 - » P1- P5 = 277V
- Ensure "MTR PWR" is connected to correct voltages (115V/P7 or 208V/P3 or 230V/P3 or 277V/P3). See figure 6 below.

FIGURE 6

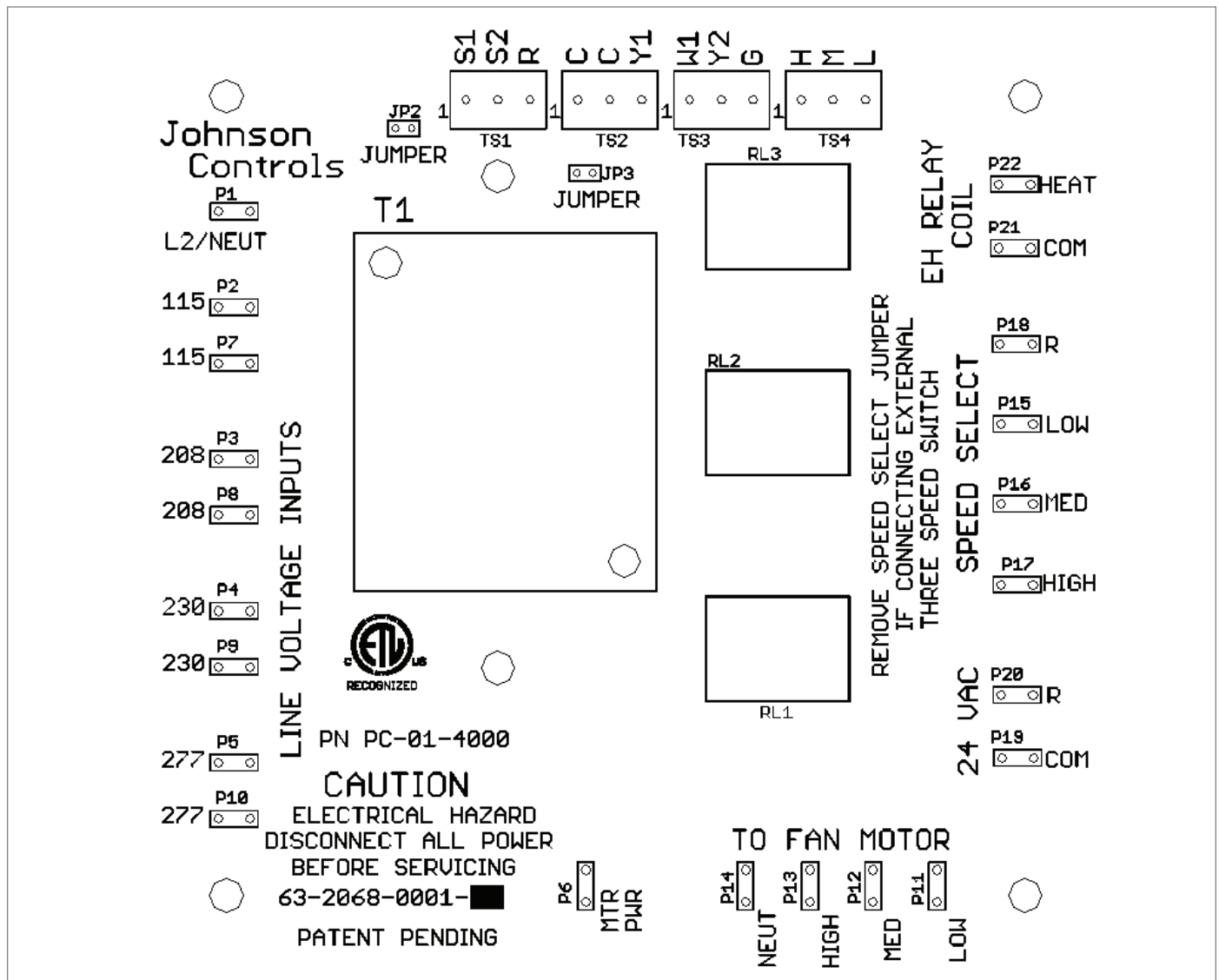

SECTION 3 - NORMAL OPERATION AND PERIODIC MAINTENANCE (CONT)

- Verify fan speed will change from High, Medium, and Low by utilizing remote 3-speed switch, thermostat or connecting by P18 to P15, P18 to P16, or P18 to P17. If fan speeds are adjustable the relay board is producing 24 Volts.
- If board is not working, measure 24 volts between P20 and P19, if 24 volts (19-29 VAC) is not present then measure across terminals S1 and R, if 24 volts (19-29 VAC) is not present then return board to local sales representative.
- Verify jumper wire JP3 (Figure 8) or wire (Figure 7) is installed between W2 and R.



NOTE - Either JP3 or wire jumper must always be installed unless thermostat drawing indicates otherwise.

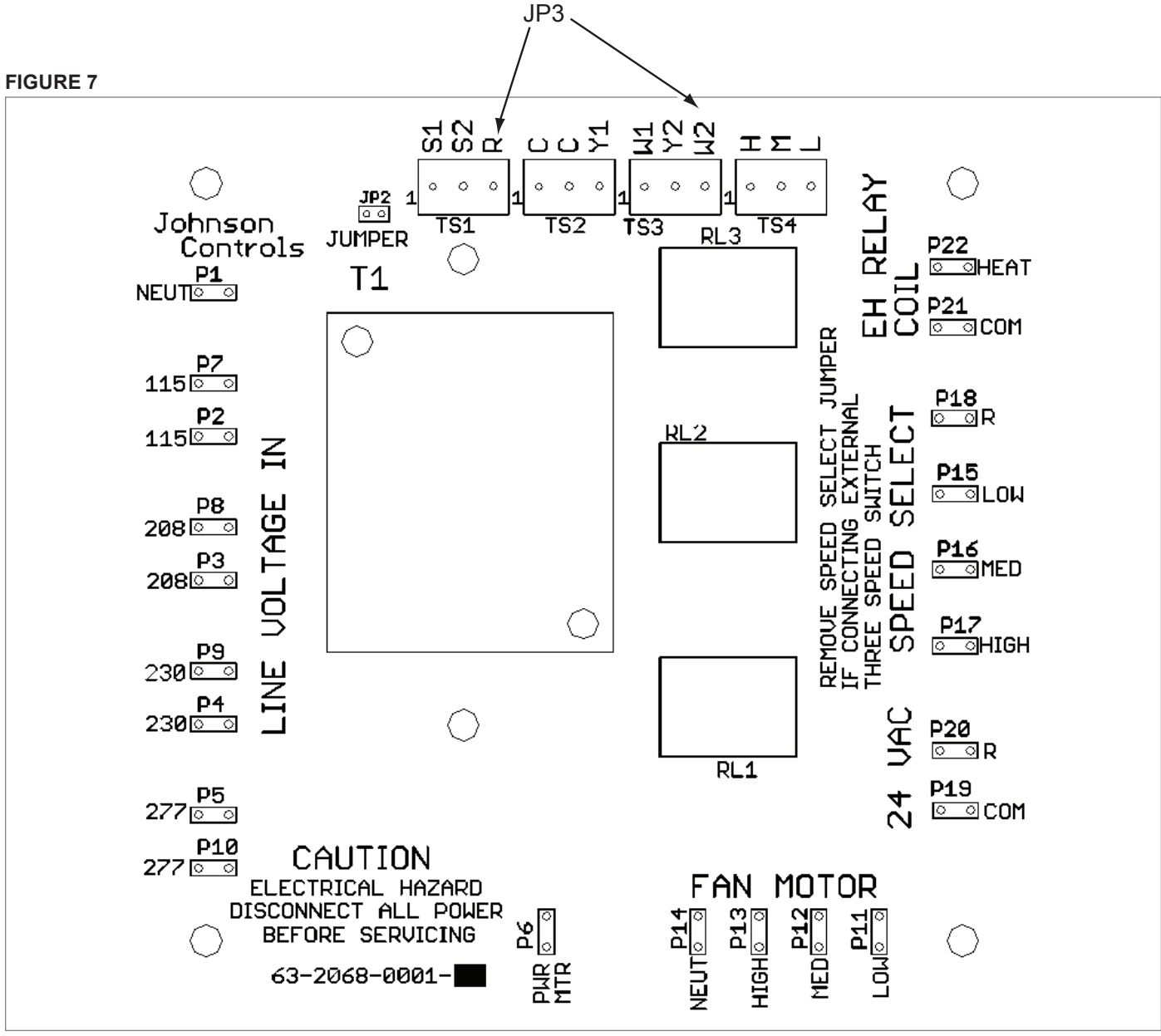

SECTION 3 - NORMAL OPERATION AND PERIODIC MAINTENANCE (CONT)

FIGURE 8

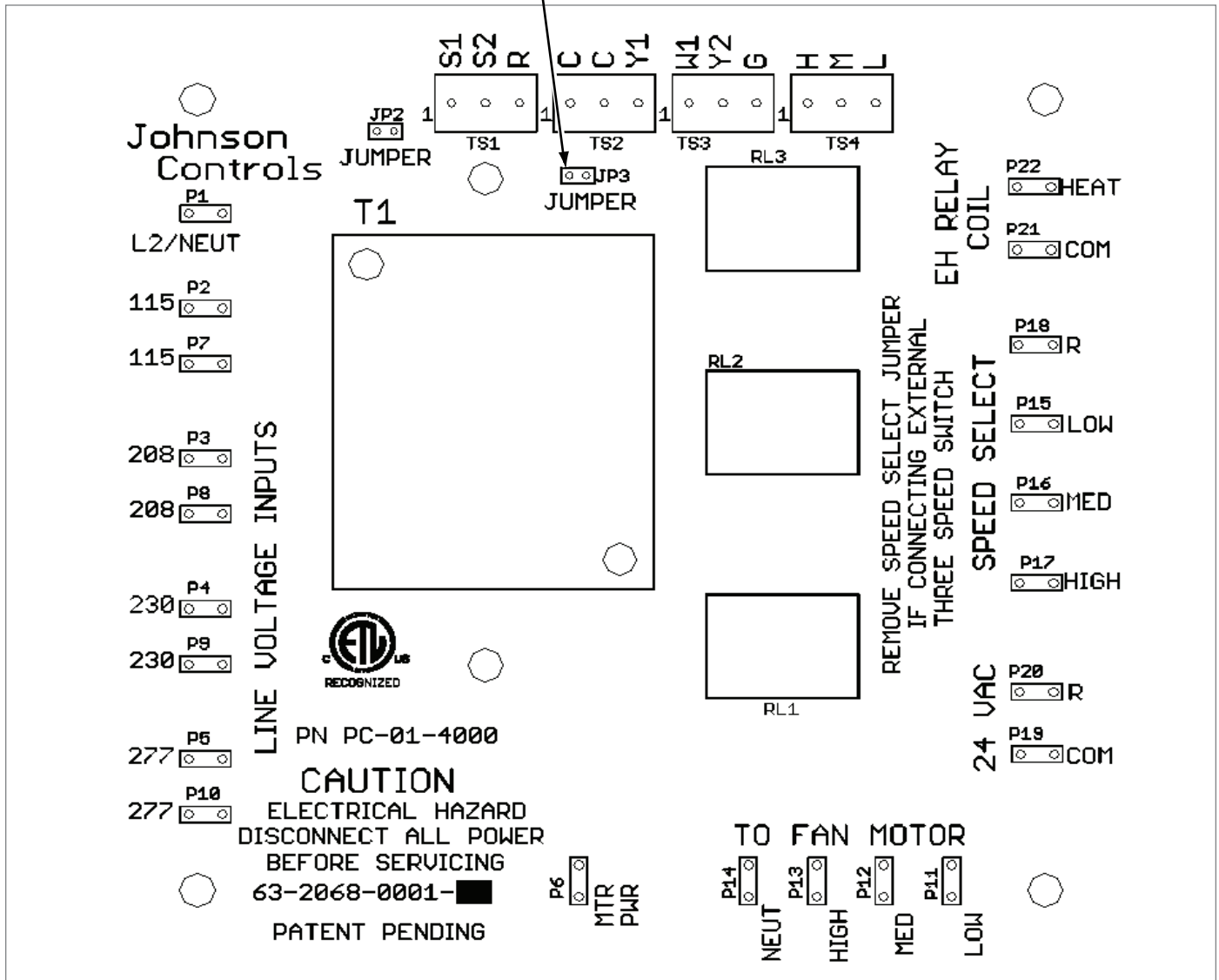

SECTION 3 - NORMAL OPERATION AND PERIODIC MAINTENANCE (CONT)

EXAMPLE WIRING DIAGRAMS - TYPICAL 24VAC CONTROL DRAWING

7. IF FLOAT SWITCH PROVIDED, ATTACH JP2 TO ONE PIN ONLY; OTHERWISE ATTACH TO BOTH PINS.
8. WIRE FIELD SUPPLIED START/STOP CONTACT IN SERIES WITH OPTIONAL FLOAT SWITCH, IF PROVIDED. OTHERWISE, INSTALL JP2.
9. OPTIONAL DOOR INTERLOCKING DISCONNECT MAY BE PROVIDED IN LIEU OF TOGGLE DISCONNECT.

1. FIELD WIRING MUST BE COPPER CONDUCTOR, RATED AT 75°C MINIMUM.
2. ADDITIONAL MOTOR WIRED IN PARALLEL.
3. REMOVE SPEED SELECT JUMPER JP1 IF T-STAT OR 3 SPEED SWITCH PROVIDED. OTHERWISE, TO CHANGE SPEED, REMOVE JUMPER FROM "HIGH" TERMINAL AND CONNECT TO "MED" OR "LOW" TERMINAL.
4. OPTIONAL ITEM SHOWN. SEE ORDER ACKNOWLEDGEMENT FOR OPTIONAL ITEM REQUIREMENTS.
5. FIELD WIRING IS REQUIRED IF VALVE WIRING NOT SUPPLIED, OR EXTERNAL TO UNIT.
6. REMOVE JP3 FOR REMOTE CONTROL USING "C".

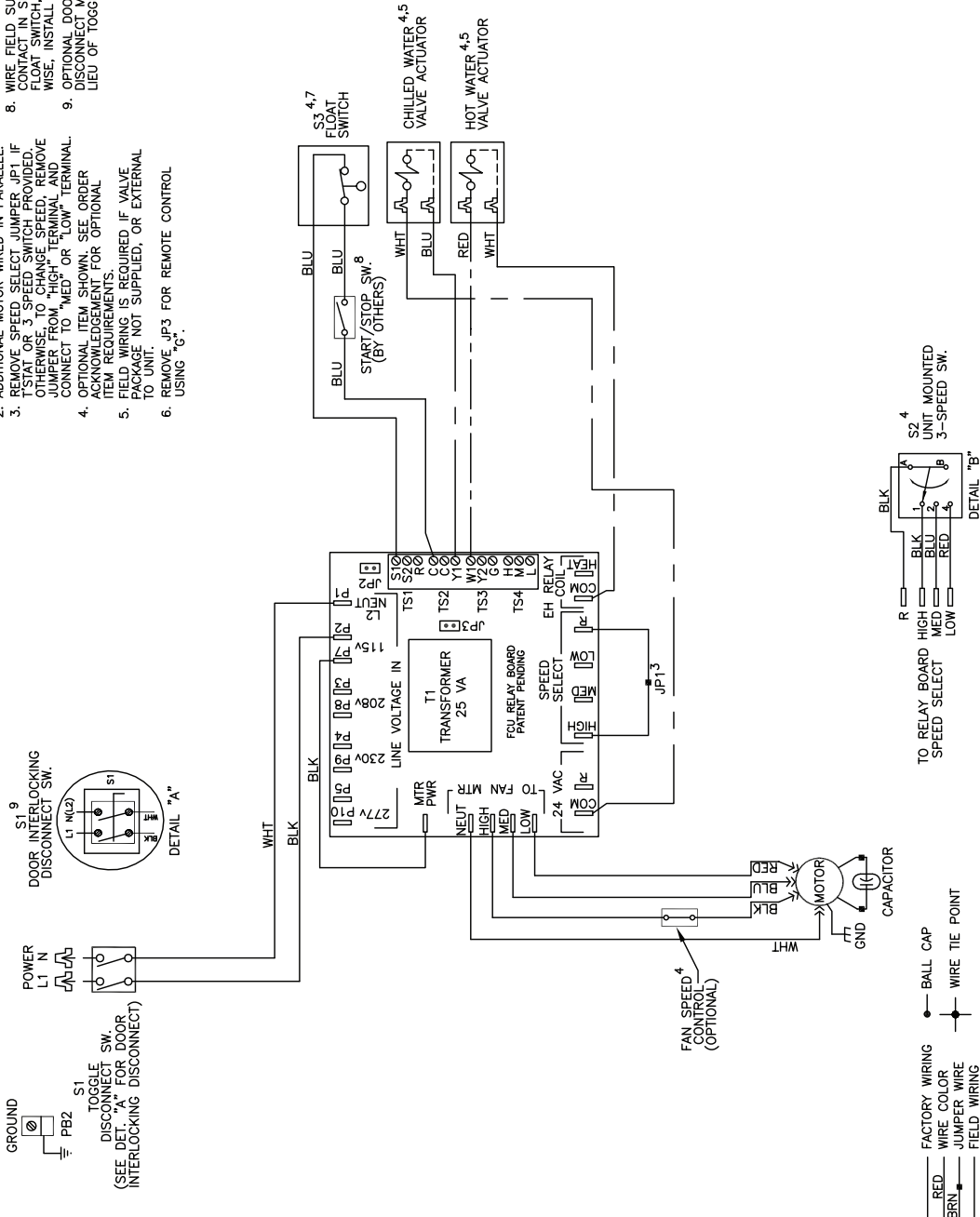

SECTION 3 - NORMAL OPERATION AND PERIODIC MAINTENANCE (CONT)

EXAMPLE WIRING DIAGRAMS (CONTINUED)

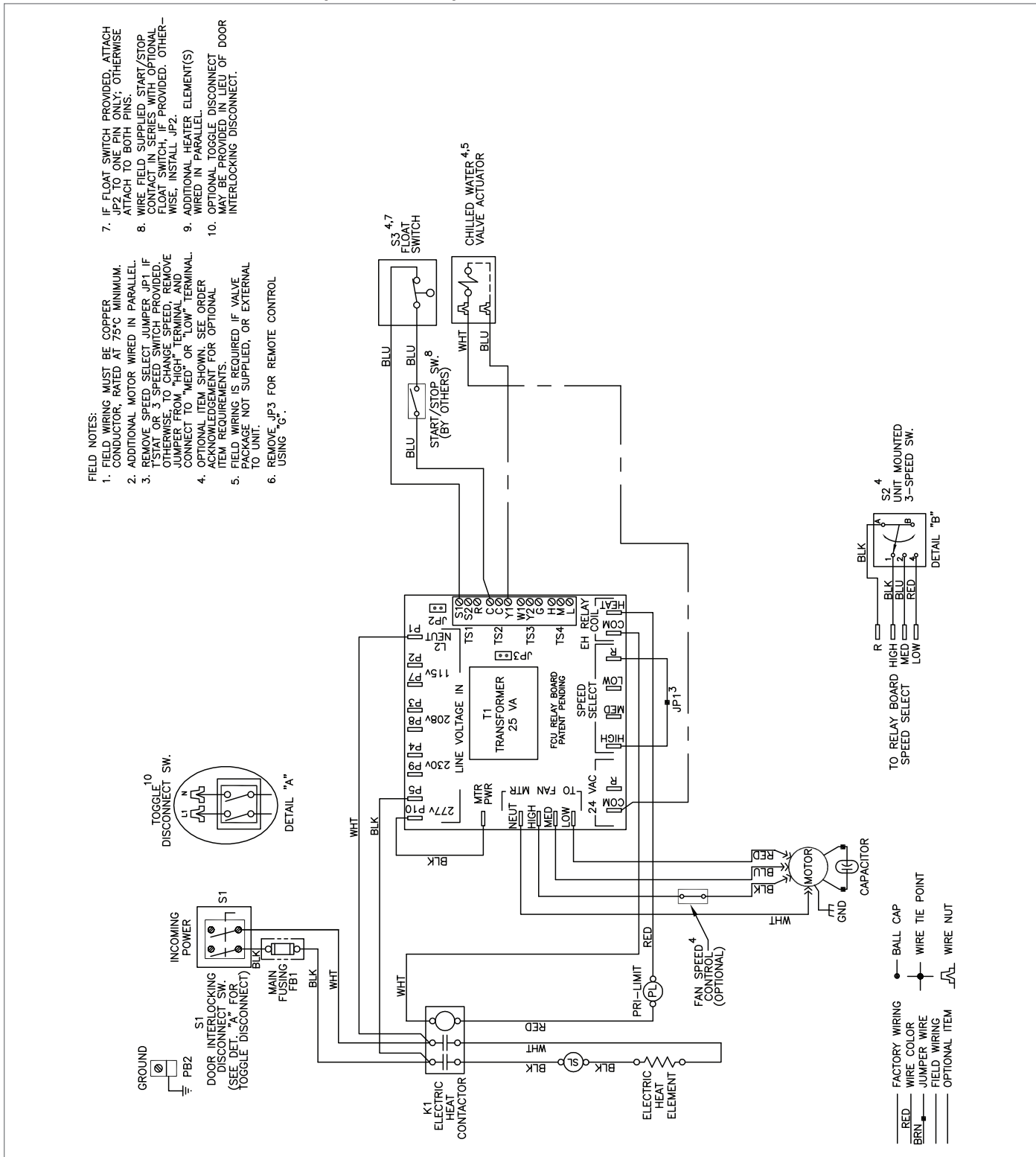

SECTION 3 - NORMAL OPERATION AND PERIODIC MAINTENANCE (CONT)

EXAMPLE WIRING DIAGRAMS (CONTINUED) - WITH ECM MOTOR

- NOTES:**
1. INCOMING POWER WIRE FOR L20 OR 277 VOLT IS WHITE & 208 OR 230 VOLT WIRE IS RED.
 2. FIELD WIRING MUST BE COPPER CONDUCTOR, RATED AT 75°C MINIMUM.
 3. OPTIONAL ITEM SHOWN, SEE ORDER ACKNOWLEDGMENT FOR OPTIONAL ITEM REQUIREMENTS.
 4. WIRE FIELD PROVIDED START/STOP CONTACT IN SERIES WITH OPTIONAL FLOAT SWITCH (IF SUPPLIED). IF OPTIONAL FLOAT SWITCH IS NOT SUPPLIED, WIRE FIELD PROVIDED START/STOP CONTACT IN PLACE OF FACTORY INSTALLED JUMPER (JP2).
 5. OPTIONAL DOOR INTERLOCKING MAY BE PROVIDED IN LIEU OF LINE BLOCK AND OPTIONAL TOGGLE SWITCH.
 6. JUMPER IS FACTORY INSTALLED. IF OPTIONAL FLOAT SWITCH IS NOT SUPPLIED, ONLY REQUIRED IF MOTORIZED DAMPER PROVIDED AND THERMOSTAT NOT PROVIDED. REMOVE FOR REMOTE FAN CONTROL USING "G" TERMINAL.
 8. P2 IS COMMON TO TERMINAL 15 OF THE ETPWM1.
 9. INSTALL JUMPER JP1 BETWEEN PINS 1 & 2 FOR 120 VAC APPLICATIONS ONLY.

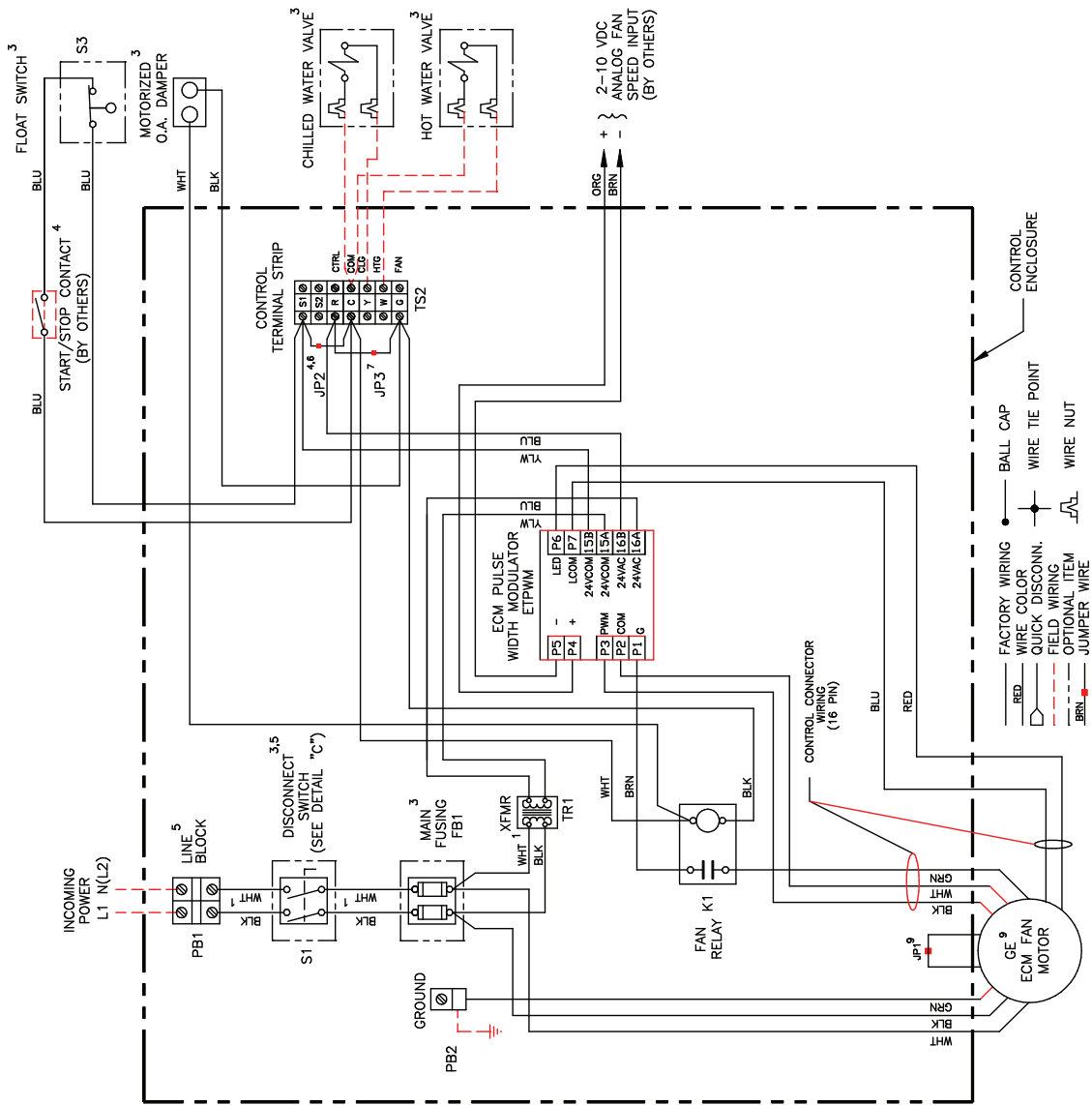
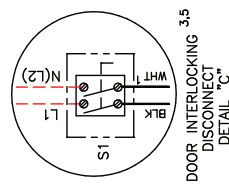

SECTION 3 - NORMAL OPERATION AND PERIODIC MAINTENANCE (CONT)

INSTRUCTIONS FOR REMOTE THERMOSTAT OR REMOTE 3-SPEED SWITCH

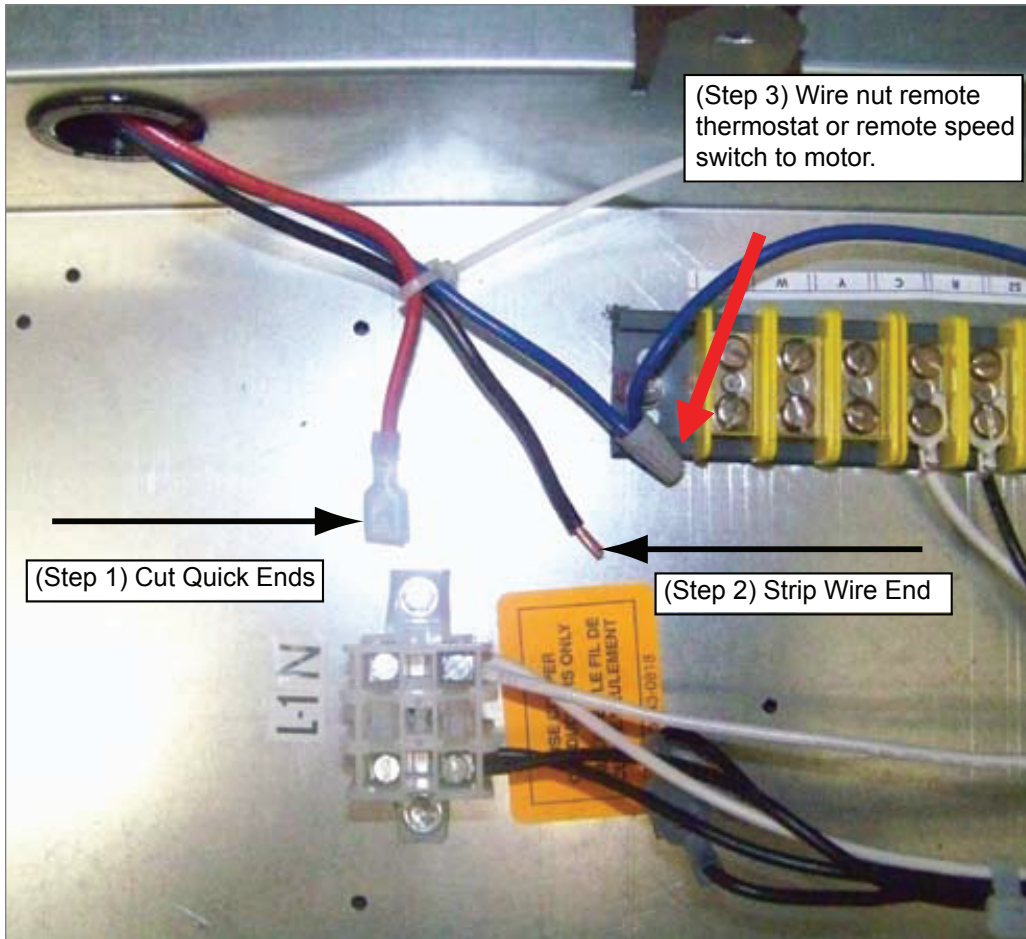

Step 1 - Cut quick ends.

Step 2 - Strip wire end.

Step 3 - Wire nut remote thermostat or remote 3-speed switch on motor.

SECTION 4 - INSPECTION & START-UP CHECKLIST

RECEIVING & INSPECTION

- Unit received undamaged.
- Unit arrangement/hand correct.
- Unit received complete as ordered.
- Unit structural support complete and correct.

HANDLING & INSTALLATION

- Unit mounted level and square.
- Proper electrical service provided.
- Proper service switch/disconnect provided.
- Proper chilled water line size to unit.
- Proper refrigerant line sizes to unit.
- Proper steam condensate trap on return line.
- All services to unit in code compliance.
- Proper access provided for unit and accessories.
- Proper overcurrent protection provided.
- Proper hot water line to unit.
- Proper steam line sizes to unit.
- Proper steam supply pressure to unit (15psi max).
- All shipping screws and braces removed.

COOLING/HEATING CONNECTIONS

- Protect valve package components from heat.
- Connect field piping to unit.
- Install drain line and traps as required.
- Install condensate pan under piping as required.
- Mount valve packages.
- Pressure test all piping for leaks.
- Insulate all piping as required.

DUCTWORK CONNECTIONS

- Install ductwork, fittings and grilles as required.
- Control outside air for freeze protection.
- Proper supply and return grille type and size used.
- Insulate all ductwork as required.

ELECTRICAL CONNECTIONS

- Refer to unit wiring diagram.
- All field wiring in code compliance.
- Connect incoming power service or services.

UNIT STARTUP

- General visual unit and system inspection.
- Record ambient temperature.
- Close all unit isolation valves.
- Fill systems with water/refrigerant.
- All ductwork and grilles in place.
- Start fans, etc.
- Check all ductwork and units for air leaks.
- Record all final settings for future use.
- Check all dampers for proper operation.
- Verify proper heating operation.
- Record electrical supply voltage.
- Check all wiring for secure connections.
- Flush water systems.
- Vent water systems as required.
- All unit panels and filters in place.
- Check for overload condition of all units.
- Balance air systems as required.
- Check piping and ductwork for vibration.
- Verify proper cooling operation.
- Reinstall all covers and access panels.



1401 N. Plano Rd. | Richardson, TX 75081 | Tel: 972.680.9136 | Fax: 972.497.0450
www.krueger-hvac.com | kruegerinfo@krueger-hvac.com