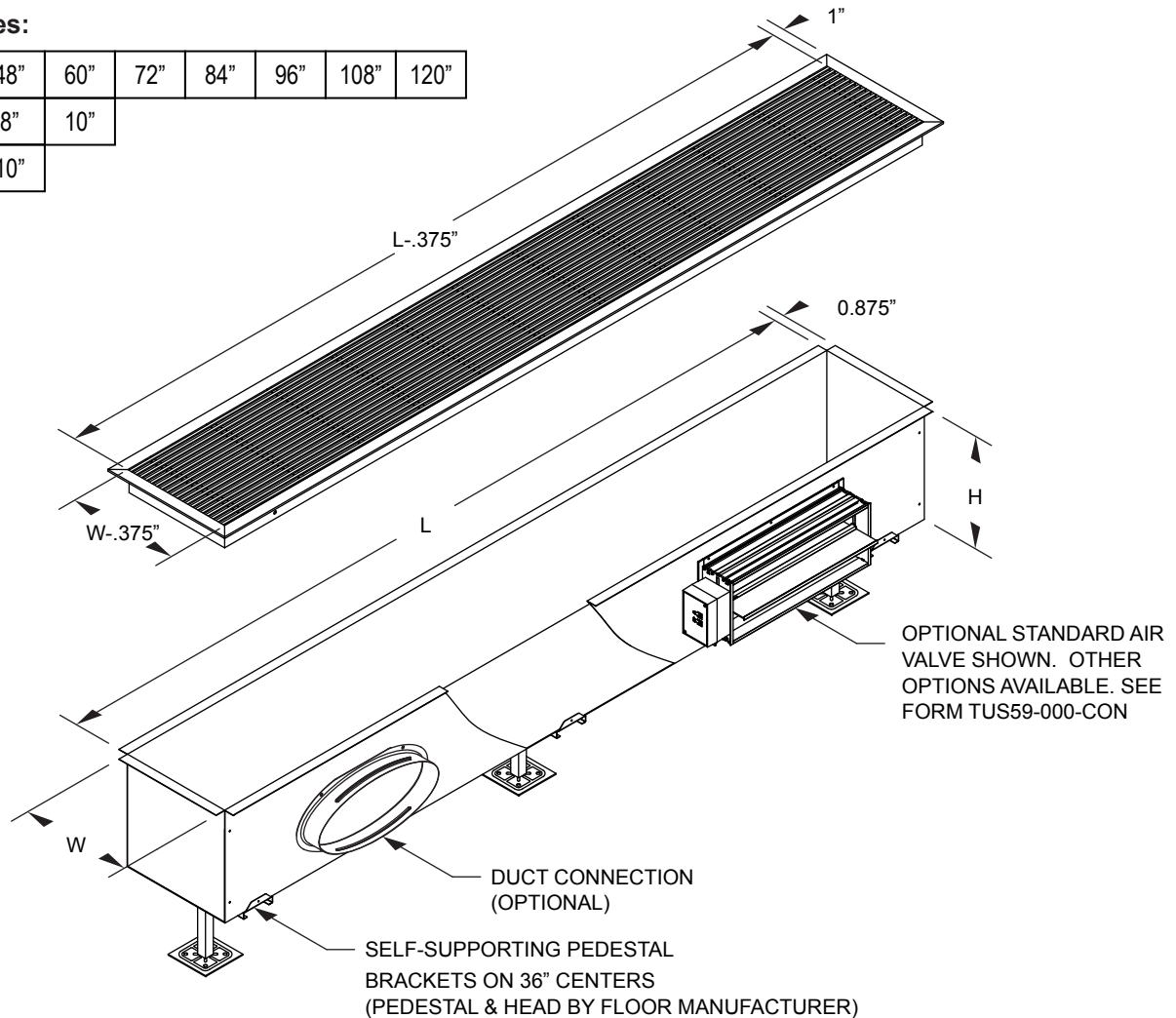

FDT
Linear Trough Unit
SUBMITTAL SHEET
Available Sizes:

L	36"	48"	60"	72"	84"	96"	108"	120"
W	6"	8"	10"					
H	8"	10"						

STANDARD FEATURES:

- Aluminum linear bar grille
- 1250 lbs. maximum load rating
- Complies with NFPA 90a
- 20 gauge pre-painted black galvanized steel plenum

OPTIONAL FEATURES:

- VAV air valves
 - Standard Extended
- Duct Connections
 - Ellipse Round Rectangle

LINEAR BAR GRILLE OPTIONS:

- End Border
 - End Caps Butt Cut
 - Left End Cap Right End Cap

INSTALLATION:

- A 2.5" minimum clearance is required under the FDT unit.
- Required opening: L x W

STANDARD COLOR OPTIONS:

- A - Black (RAL 9011)
- B - Gray (RAL 7012)
- C - Antique Copper (09/90180)
- D - Silver Hammertone (09/90250)
- E - Antique Gray (09-90170)
- F - Putty (RAL 9002)
- G - Beige (RAL 1019)
- H - Antique Gold (09/90200)
- I - Antique Silver (09/90190)
- J - Dark Brown (RAL 8014)
- X - Custom (RAL _____)

Revision Date: 05-15	Form: TUS59-S00-C00-0	Replaces: New
-----------------------------	------------------------------	----------------------