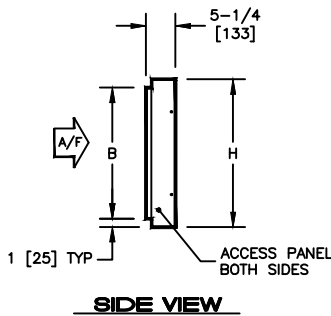
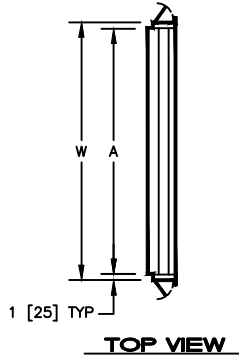

AVAILABLE FILTER OPTIONS:  
 2" [51mm], 30% PLEATED (MERV 7)

SIZE	H	W	A	B	ACCESS PANEL H X W	WEIGHT		FILTER SIZES
						SINGLE WALL LBS (kg)	DOUBLE WALL LBS (kg)	
02	17-3/8 [441]	28 [711]	26 [660]	15-3/8 [391]	17-3/8 X 4 [441 X 102]	20 [9]	25 [11]	(1) 16 X 20 [406 X 508]
03	17-3/8 [441]	34 [864]	32 [813]	15-3/8 [391]	17-3/8 X 4 [441 X 102]	20 [9]	25 [11]	(1) 16 X 25 [406 X 635]
04	17-3/8 [441]	42 [1069]	40 [1016]	15-3/8 [391]	17-3/8 X 4 [441 X 102]	25 [11]	30 [14]	(2) 16 X 20 [406 X 508]
06	26-3/8 [670]	42 [1069]	40 [1016]	24-3/8 [619]	26-3/8 X 4 [670 X 102]	30 [14]	37 [17]	(2) 20 X 25 [508 X 635]
08	26-3/8 [670]	46 [1168]	44 [1118]	24-3/8 [619]	26-3/8 X 4 [670 X 102]	35 [16]	42 [19]	(2) 20 X 25 [508 X 635]
10	26-3/8 [670]	56 [1422]	54 [1372]	24-3/8 [619]	26-3/8 X 4 [670 X 102]	35 [16]	42 [19]	(1) 16 X 25 (2) 20 X 25 [406 X 635] [508 X 635]
12	41-3/16 [1046]	64 [1626]	62 [1575]	39-3/16 [995]	41-3/16 X 4 [1046 X 102]	60 [27]	69 [31]	(4) 20 X 25 [508 X 635]
14	41-3/16 [1046]	68 [1727]	66 [1676]	39-3/16 [995]	41-3/16 X 4 [1046 X 102]	60 [27]	69 [31]	(8) 16 X 20 [406 X 508]
17	41-3/16 [1046]	80 [2032]	78 [1981]	39-3/16 [995]	41-3/16 X 4 [1046 X 102]	60 [27]	74 [34]	(6) 20 X 25 [508 X 635]

**NOTES:**

1. ALL DIMENSIONS ARE INCHES [MM]
2. ALL DIMENSIONS ARE ±1/8" [3]
3. METRIC VALUES ARE SOFT CONVERSION
4. ALL DRAWINGS SUBJECT TO CHANGE WITHOUT PRIOR NOTICE
5. DUCT COLLARS ARE 1" [25] ALL AROUND
6. RIGHT HAND UNIT SHOWN

Revision Date: 11/14	Form: AHMS07-FL02	Replaces: NEW
----------------------	-------------------	---------------