

**KBM - AIR HANDLER, MODULAR**

COIL CONNECTION LOCATION - 4 ROW WATER COIL IN PRE-HEAT WITH DX COIL IN COOLING

**SUBMITTAL SHEET**

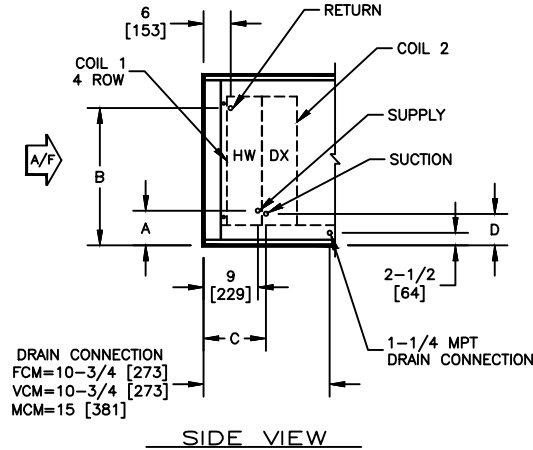

		COIL 2											
SIZE	3 ROW				4 ROW				6 ROW				
	A	B	C	D	A	B	C	D	A	B	C	D	
02	6-1/4 [159]	16-3/4 [425]	12-1/4 [312]	4-1/4 [108]	6-1/4 [159]	16-3/4 [425]	12-1/4 [312]	5 [127]	6-1/4 [159]	16-3/4 [425]	11-3/4 [299]	5 [127]	
03	6-1/4 [159]	16-3/4 [425]	12-1/4 [312]	4-1/4 [108]	6-1/4 [159]	16-3/4 [425]	12-1/4 [312]	5 [127]	6-1/4 [159]	16-3/4 [425]	11-3/4 [299]	5 [127]	
04	6-1/2 [165]	17 [432]	12-1/4 [312]	4-3/4 [121]	6-1/2 [165]	17 [432]	12-1/4 [312]	5-1/4 [134]	6-1/2 [165]	17 [432]	11-3/4 [299]	5-1/4 [134]	
06	6-1/2 [165]	24-1/2 [622]	12-1/4 [312]	4-3/4 [121]	6-1/2 [165]	24-1/2 [622]	12-1/4 [312]	5-1/2 [140]	6-1/2 [165]	24-1/2 [622]	11-3/4 [299]	6-3/4 [172]	
08	6-3/4 [171]	29-3/4 [756]	12-1/4 [312]	4-3/4 [121]	6-3/4 [171]	29-3/4 [756]	12-1/4 [312]	5-1/2 [140]	6-3/4 [171]	29-3/4 [756]	11-3/4 [299]	5-1/2 [140]	
10	7-1/4 [185]	29-1/2 [749]	12-1/4 [312]	4-3/4 [121]	7-1/4 [185]	29-1/2 [749]	12-1/4 [312]	5-1/2 [140]	7-1/4 [185]	29-1/2 [749]	11-3/4 [299]	5-1/2 [140]	
12	7-1/4 [185]	35-1/4 [895]	12-1/4 [312]	5-3/4 [147]	7-1/4 [185]	35-1/4 [895]	12-1/4 [312]	6-1/4 [159]	7-1/4 [185]	35-1/4 [895]	11-3/4 [299]	6-1/2 [166]	
14	7-1/4 [185]	37-3/4 [959]	12-1/4 [312]	5-3/4 [147]	7-1/4 [185]	37-3/4 [959]	12-1/4 [312]	6-1/2 [166]	7-1/4 [185]	37-3/4 [959]	11-3/4 [299]	7-1/2 [191]	
17	7-1/2 [191]	38 [965]	12-1/4 [312]	6 [153]	7-1/2 [191]	38 [965]	12-1/4 [312]	6-3/4 [172]	7-1/2 [191]	38 [965]	11-3/4 [299]	8 [204]	

NOTES:

- ALL DIMENSIONS ARE INCHES [MM]
- ALL DIMENSIONS ARE ±1/8" [3]
- METRIC VALUES ARE SOFT CONVERSION
- LIQUID LINE CONNECTION IS LOCATED INSIDE OF CABINET; FIELD PENETRATION OF CABINET IS REQUIRED
- SEE SELECTION PROGRAM FOR CONNECTION SIZES
- DX COILS ARE ONLY AVAILABLE IN 3, 4, 6, OR 8 ROWS
- HOT WATER COILS ARE ONLY AVAILABLE IN 1, 2, 3, OR 4 ROWS
- MODULES FCM AND VCM CAN HAVE UP TO A TOTAL OF 8 ROWS OF COIL
- MODULE MCM CAN HAVE UP TO A TOTAL OF 10 ROWS OF COIL

Revision Date: 12/14	Form: AHMS05-WC17	Replaces: NEW
----------------------	-------------------	---------------