

KBM - AIR HANDLER, MODULAR
 MFM - MEDIUM SMARTRAK MIXING BOX WITH FLAT FILTERS, SIZE 14

SUBMITTAL SHEET

AVAILABLE FILTER OPTIONS:
 2" [51mm], 30% PLEATED (MERV 7)

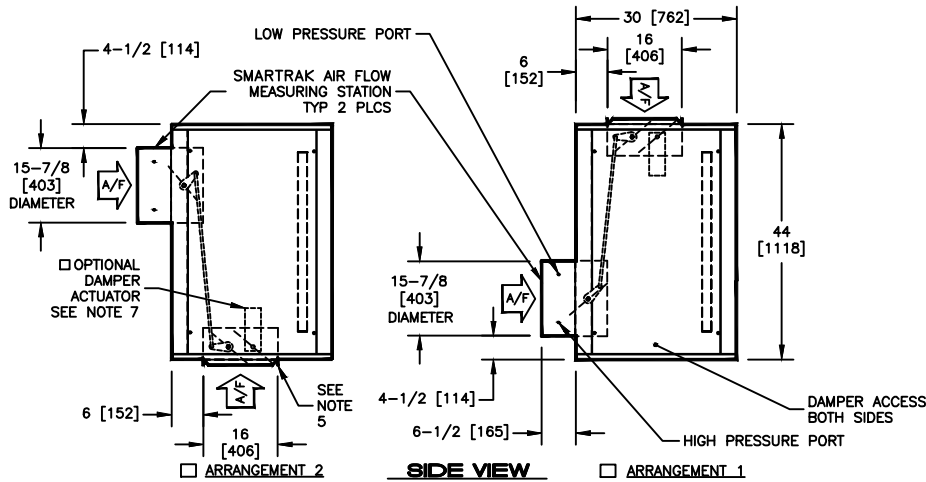
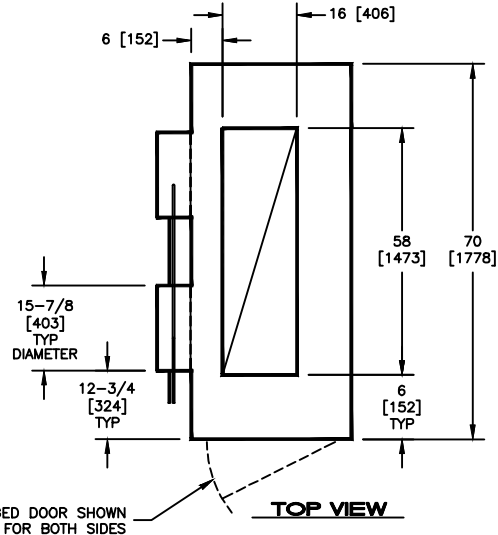

ACCESS PANEL H X W	WEIGHT		FILTER SIZES
	SINGLE WALL LBS (kg)	DOUBLE WALL LBS (kg)	
42 X 24 [1067 X 610]	285 [129]	345 [156]	(8) 16 X 20 [406 X 508]

NOTES:

1. ALL DIMENSIONS ARE INCHES [MM]
2. ALL DIMENSIONS ARE ±1/8" [3]
3. METRIC VALUES ARE SOFT CONVERSION
4. ALL DRAWINGS SUBJECT TO CHANGE WITHOUT PRIOR NOTICE
5. DUCT COLLARS ARE 1" [25] ALL AROUND
6. DAMPER LINKAGE IS FACTORY PROVIDED AND INSTALLED
7. OPTIONAL DAMPER ACTUATOR WILL BE LOCATED ON THE INSIDE OF MODULE ON THE SAME SIDE AS THE CONTROL ENCLOSURE
8. RIGHT HAND UNIT SHOWN
9. OPTIONAL HINGED DOOR IS REMOVABLE, BUT MUST BE OPENED 90 DEGREES FOR REMOVAL
10. HIGH PRESSURE PORT AND LOW PRESSURE PORT TUBING WILL BE RUN TO THE SAME SIDE OF THE MODULE AS THE MOTOR SHEAVE

Revision Date: 11/14	Form: AHMS03-MB04	Replaces: NEW
----------------------	-------------------	---------------