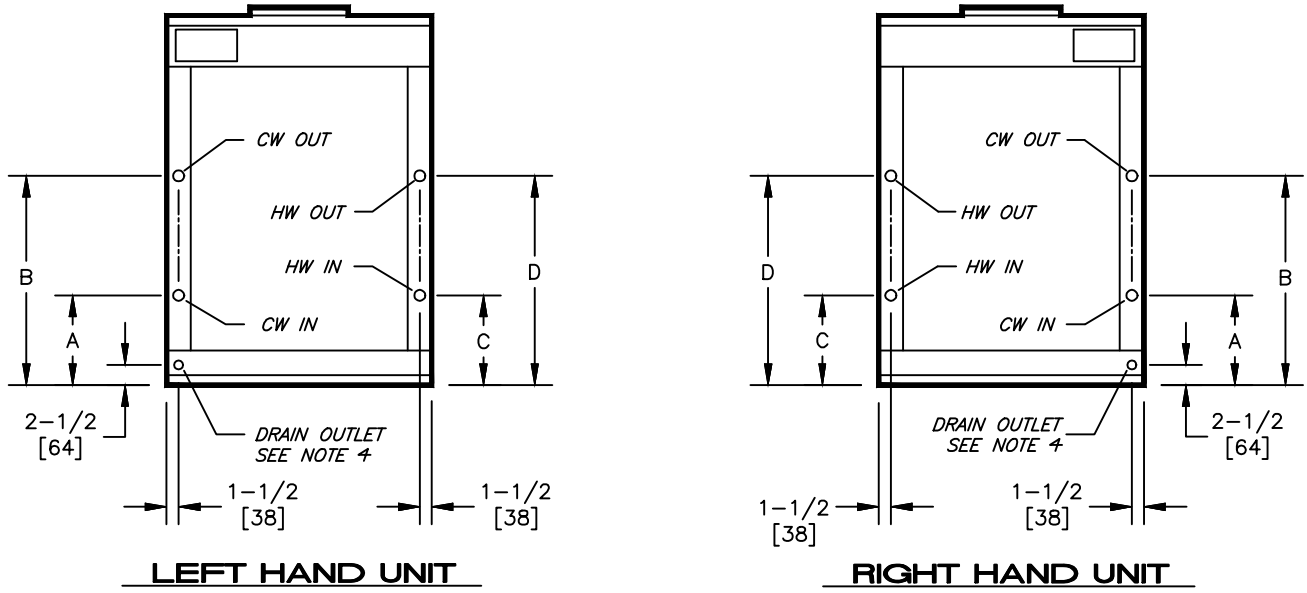

FIG. 2
4/1, AND 4/2 ROW
(HW COIL IN PRE-HEAT POSITION)



INTERNAL COIL												
SIZE	4/1 ROW COILS						4/2 ROW COILS					
	4 ROW			1 ROW			4 ROW			2 ROW		
	COIL CONNECTION	A	B	COIL CONNECTION	C	D	COIL CONNECTION	A	B	COIL CONNECTION	C	D
08	7/8 [23]	7-1/4 [184]	21-3/4 [552]	5/8 [16]	8 [203]	20-5/8 [524]	7/8 [23]	7-1/4 [184]	21-3/4 [552]	5/8 [16]	8 [203]	20-5/8 [524]
12			26-1/4 [667]			22-7/8 [581]			26-1/4 [667]			22-7/8 [581]
16			28-1/4 [716]			26-1/8 [664]			28-1/4 [716]			26-1/8 [664]
20			33-5/8 [854]			33-3/4 [857]			33-5/8 [854]			33-3/4 [857]
25			30-1/2 [775]			29-3/8 [746]			30-1/2 [775]			29-3/8 [746]
30	1-1/8 [29]	34-7/8 [886]	7/8 [23]	8-1/8 [206]	33-5/8 [854]	1-1/8 [29]	7-1/16 [179]	34-7/8 [886]	7/8 [23]	8-1/4 [210]	31 [787]	35-1/4 [895]

- NOTES:
1. ALL DIMENSIONS ARE INCHES [MM]
 2. ALL DIMENSIONS ARE ±1/2" [13]
 3. METRIC VALUES ARE SOFT CONVERSION
 4. STANDARD GALVANIZED DRAIN PAN HAS 1-18" ODM COPPER CONNECTION; OPTIONAL STEEL DRAIN PAN HAS 1" GALVANIZED SCH. 40 THREADED STEEL CONNECTION
 5. 4-PIPE UNITS WITH INTERNAL COILS HAVE COOLING AND HEATING CONNECTIONS ON OPPOSITE SIDES OF UNIT
 6. ALL INTERNAL HEATING COILS ARE IN THE RE-HEAT POSITION
 7. DIMENSIONS ARE BASED ON UNIT CABINET ONLY, AND DO NOT INCLUDES FILTER RACK OR BASE RAIL

Revision Date: 12/14	Form: BCS20-SWC03	Replaces: NEW
----------------------	-------------------	---------------