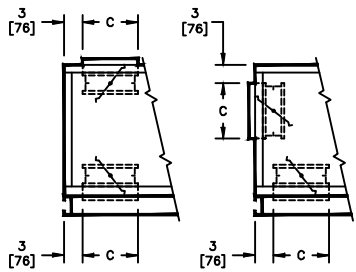
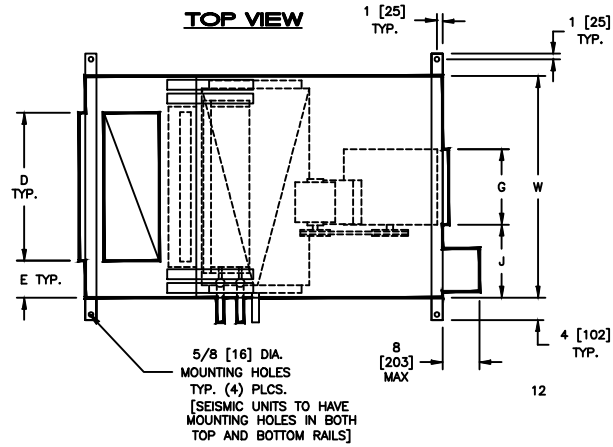
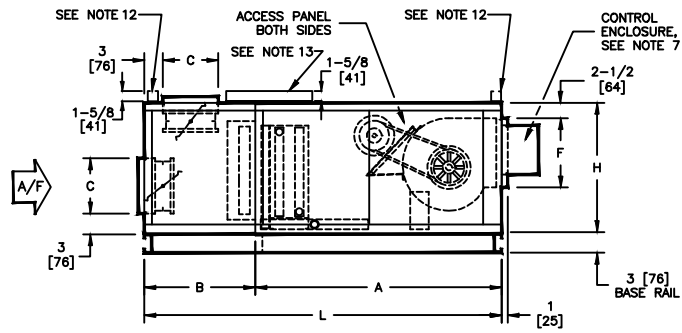

KBH - HORIZONTAL BLOWER COIL
BASIC UNIT - DISCHARGE ARRANGEMENT 3 WITH MIXING BOX
SUBMITTAL SHEET

TOP/BTM INLET
REAR/BTM INLET

REAR/TOP INLET
SIDE VIEWS

SIZE	FAN SIZE	L	W	H	A	B	C	D	E	F	G	J
08	9 X 4 [229 X 102]	58 [1473]	30 [762]	21 [533]	40 [1016]	18 [457]	9 [229]	18 [457]	6 [152]	10-1/4 [260]	6-7/8 [175]	11-9/16 [294]
12	9 X 6 [229 X 152]	58 [1473]	36 [914]	21 [533]	40 [1016]	18 [457]	9 [229]	24 [610]	6 [152]	11-1/4 [286]	8-1/4 [210]	13-7/8 [352]
16	10 X 8 [254 X 203]	58 [1473]	44 [1118]	21 [533]	40 [1016]	18 [457]	9 [229]	30 [762]	7 [178]	11-3/8 [289]	10-1/4 [260]	16-7/8 [429]
20	10 X 10 [254 X 254]	61 [1549]	50 [1270]	21 [533]	40 [1016]	21 [533]	12 [305]	36 [914]	7 [178]	11-3/8 [289]	13-1/4 [337]	18-3/8 [467]
30	15 X 9 [381 X 229]	67 [1702]	59 [1499]	30 [762]	46 [1168]	21 [533]	12 [305]	45 [1143]	7 [178]	16 [406]	13-1/4 [337]	22-7/8 [581]
40	15 X 11 [381 X 279]	70 [1778]	68 [1727]	30 [762]	46 [1168]	24 [610]	15 [381]	48 [1219]	10 [254]	16 [406]	15 [381]	26-1/2 [673]

NOTES:

- ALL DIMENSIONS ARE INCHES [MM]
- ALL DIMENSIONS ARE ±1/4" [6]
- METRIC VALUES ARE SOFT CONVERSION
- RIGHT HAND UNIT SHOWN, LEFT HAND UNIT OPPOSITE
- MOTOR/DRIVE LOCATION MAY BE SPECIFIED LEFT HAND OR RIGHT HAND
- STANDARD CONTROL ENCLOSURE LOCATION MATCHES MOTOR/DRIVE POSITION
- PROVIDE SUFFICIENT CLEARANCE TO PERMIT ACCESS TO CONTROLS AND COMPLY WITH APPLICABLE CODES AND ORDINANCES
- SEE SUBMITTAL BCS08-FR01 FOR FILTER RACK DETAILS
- OUTSIDE AND RETURN AIR DAMPER LINKAGE IS OPTIONAL
- SEE COIL CONNECTION DETAIL DRAWINGS FOR COIL CONNECTION SIZES AND LOCATIONS
- HIGH EFFICIENCY FILTER RACK NOT AVAILABLE WITH MIXING BOX
- TOP RAILS PROVIDED WITH SEISMIC CERTIFIED OPTION; ADD 1-5/8" TO 'H' DIMENSION
- TOP RAILS PROVIDED ON SIZE 30 & 40 UNITS WITH MIXING BOX AND SEISMIC CERTIFIED OPTION

Revision Date: 12/14	Form: BCS01-KBH07	Replaces: NEW
----------------------	-------------------	---------------