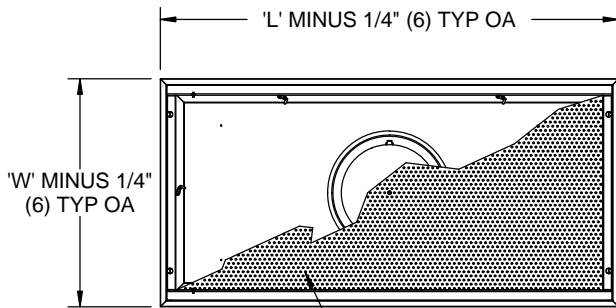
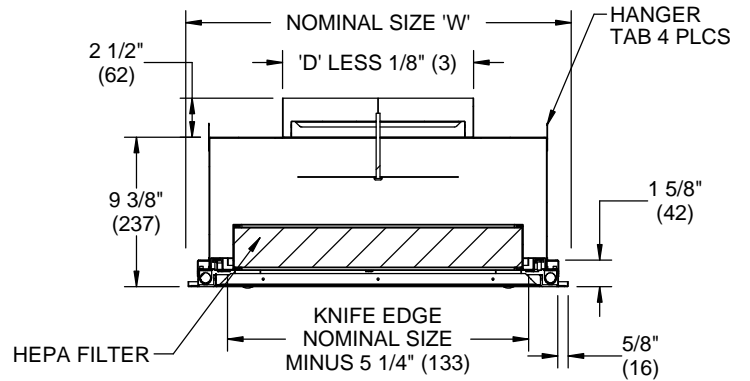
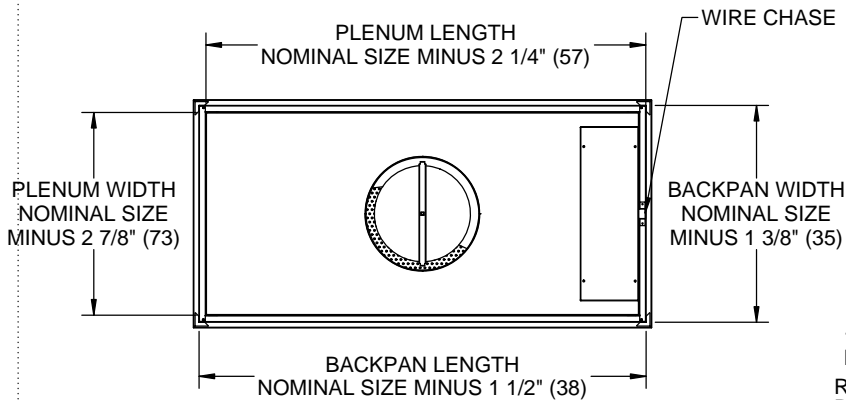
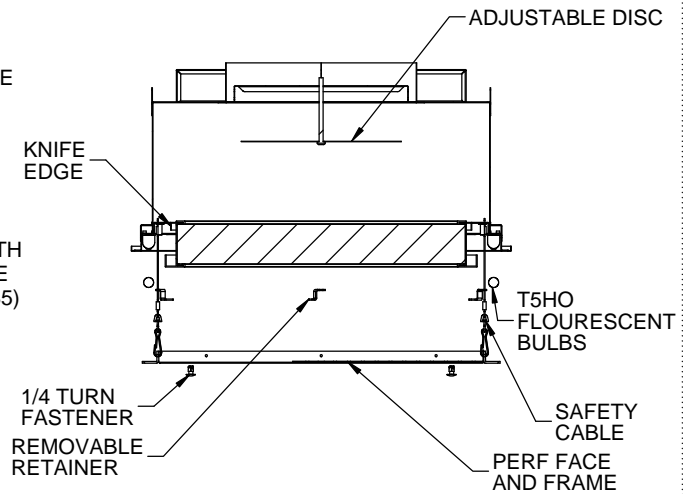

**5000HFL SERIES**
**LIGHTED LAMINAR DEVICE FOR HEPA APPLICATIONS**
**SUBMITTAL SHEET**

 PERFORATED FACES  
 3/32" (2) HOLES ON 1/4" (6)  
 STAGGERED CENTERS

**FACE VIEW**

 NOMINAL 48 x 24 SHOWN FOR REFERENCE  
 HEPA FILTER NOT SHOWN FOR CLARITY

**TYPICAL CROSS SECTION**

**TOP VIEW**

 NOMINAL 48 x 24 SHOWN FOR REFERENCE  
 HEPA FILTER NOT SHOWN FOR CLARITY

**EXPLODED SECTION DETAIL**
**NOTES:**

1. 5000HFL CONSTRUCTION IS STAINLESS STEEL
2. STANDARD FINISH IS 90-POLISHED; 44-BRITISH WHITE AVAILABLE
3. WELDED SEAMS AND SEALED INLET
4. HEPA ORDERED SEPARATELY
5. FOR F22 ORDER 5HCF23 CEILING FRAME
6. TCLP COMPLIANT
7. UL RATED LAMPS & BALLAST

DIMENSIONS ARE GIVEN AS INCHES (mm)

NOMINAL UNIT SIZES		NOMINAL INLET SIZES
'L'	'W'	
24" (610)	24" (610)	8" (205)
36" (915)	24" (610)	10" (254)
48" (1220)	24" (610)	12" (305)

LIGHT SPECS (PER BULB)	
QTY	TWO BULBS PER DIFFUSER
INPUT	120 TO 277 VAC 50/60 Hz 0.96 TO 0.41 AMPS
MEAN LUMENS @ 25°C	4130; 4450 (INITIAL)
MEAN LUMENS @ 35°C	4600; 5000 (INITIAL)
BULB	T5
WATTAGE	54
COLOR TEMP	4100K
CRI	85
RATED LIFE	25,000 HRS