

ASB

Introduction: ASB

The ASB high capacity chilled beam is the perfect solution for spaces with above average ventilation, cooling, and heating loads. It is a great fit for large spaces with windows and additional heat sources such as personnel or computers. This product has several options available to meet different engineering requirements and building needs.

MODEL

ASB - Active High Capacity

FEATURED OPTIONS

(See **STANDARD OPTIONS** on Page C3-17)

- Primary air flow adjustment damper.
- Integrated exhaust valve.
- 2-way or 1-way (right or left) available.
- Right or left duct connection.
- Available in lengths from 48" to 120" (12" increments).
- Custom color matching available.
- 5 nozzle sizes available.

ASB Dimensional Information

ASB DUCT & SIDE VIEWS, 48" - 96"

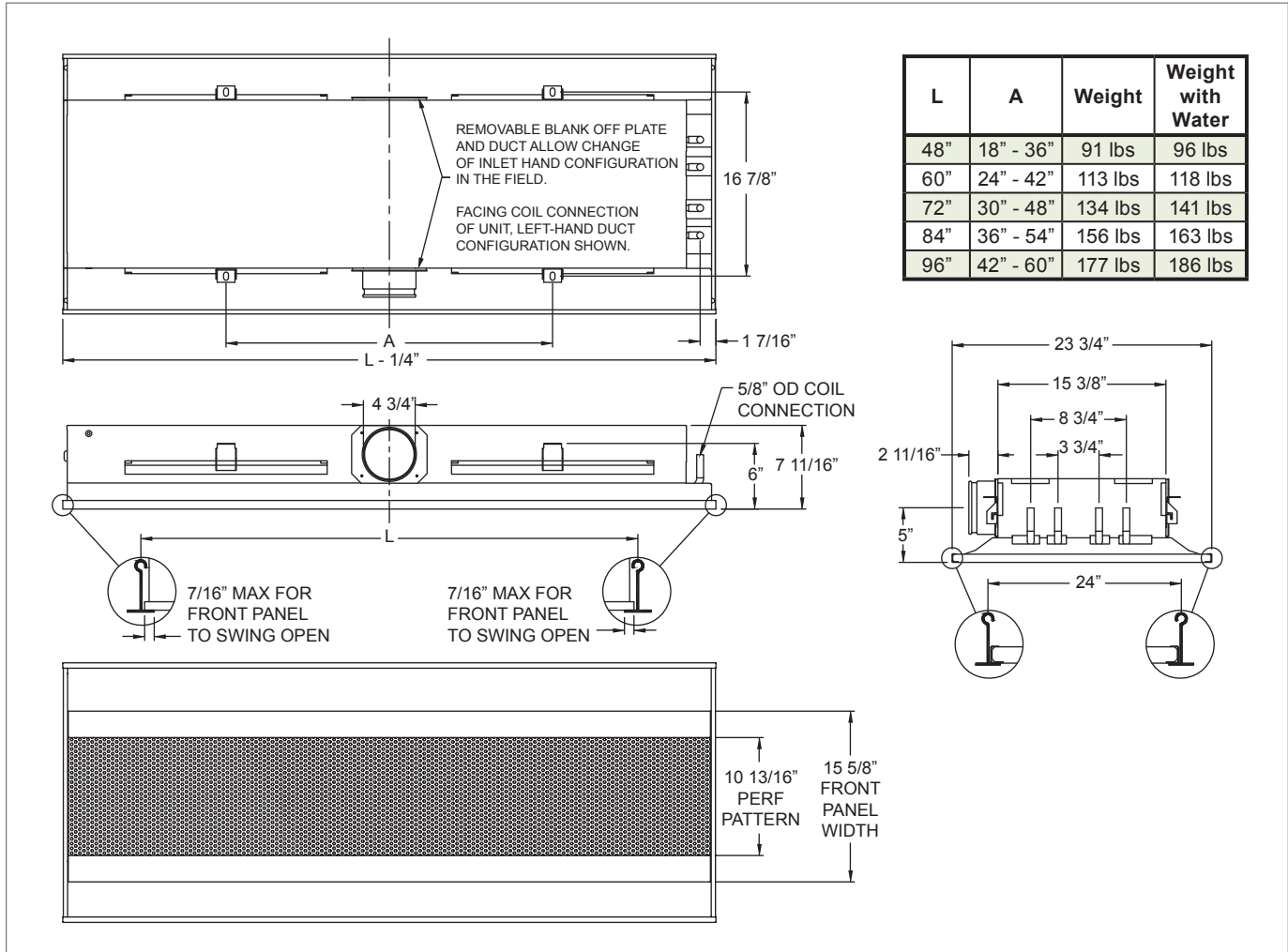



CHILLED BEAMS

ASB Dimensional Information

ASB DUCT & SIDE VIEWS, 108" - 144"

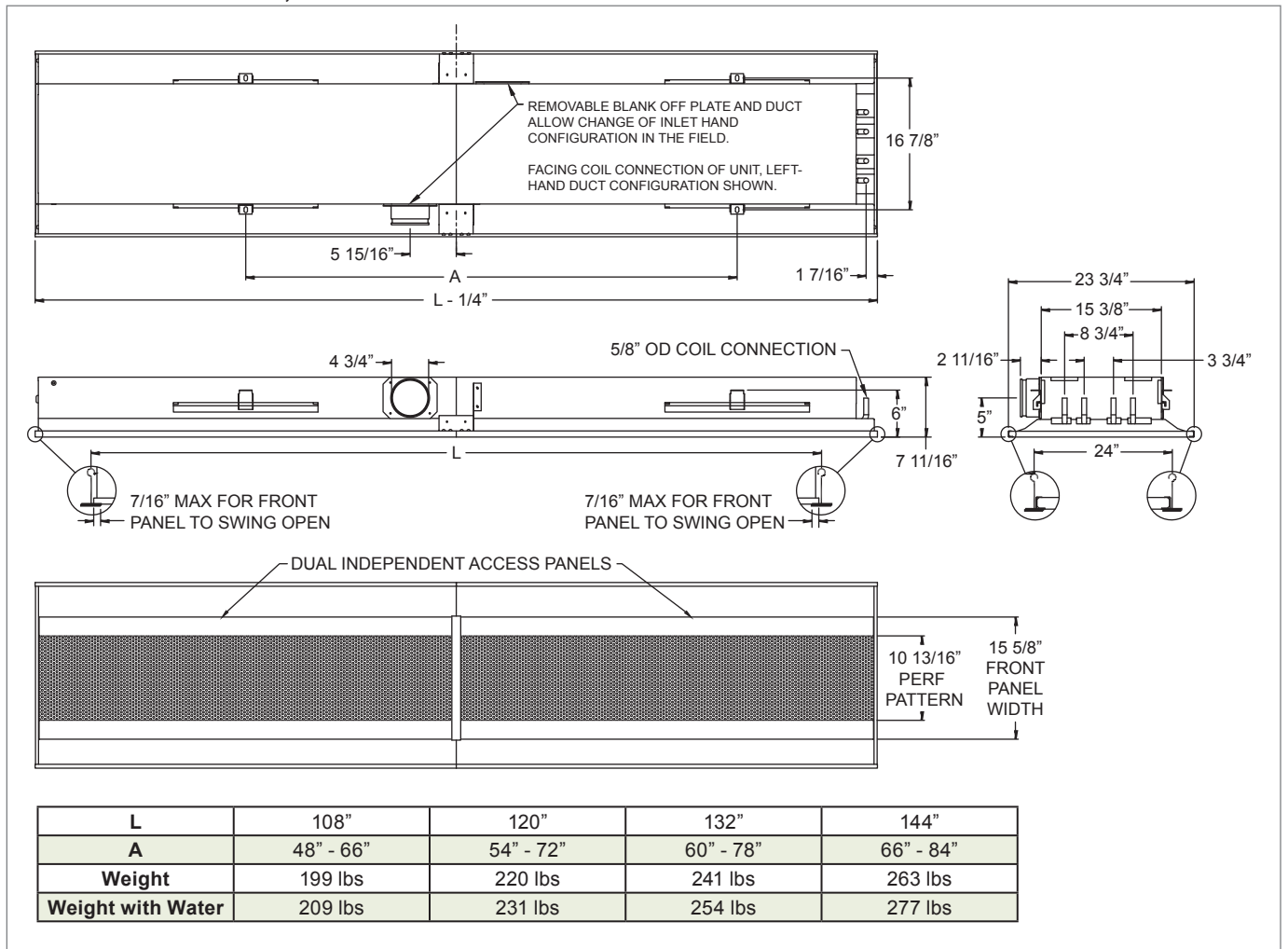

© KRUEGER 2012

ASB