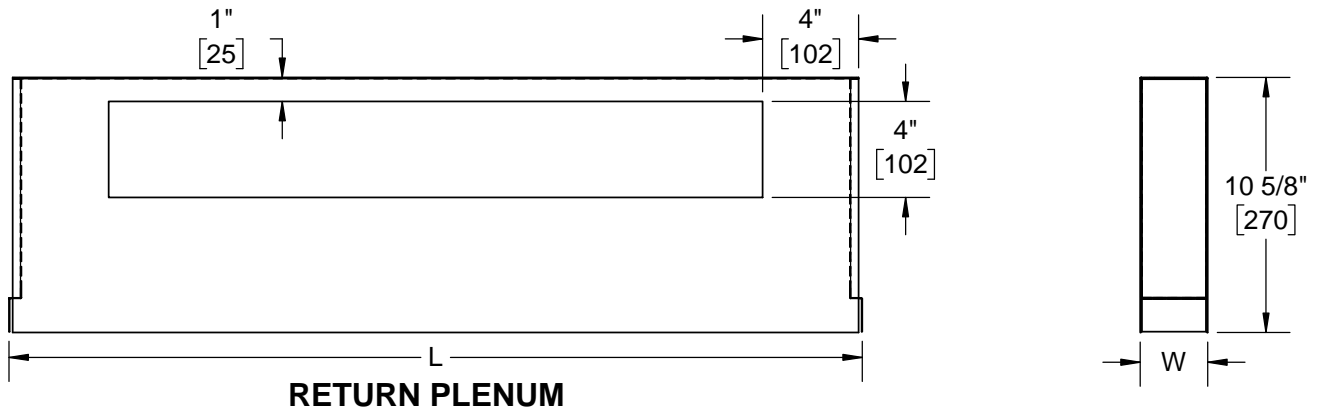
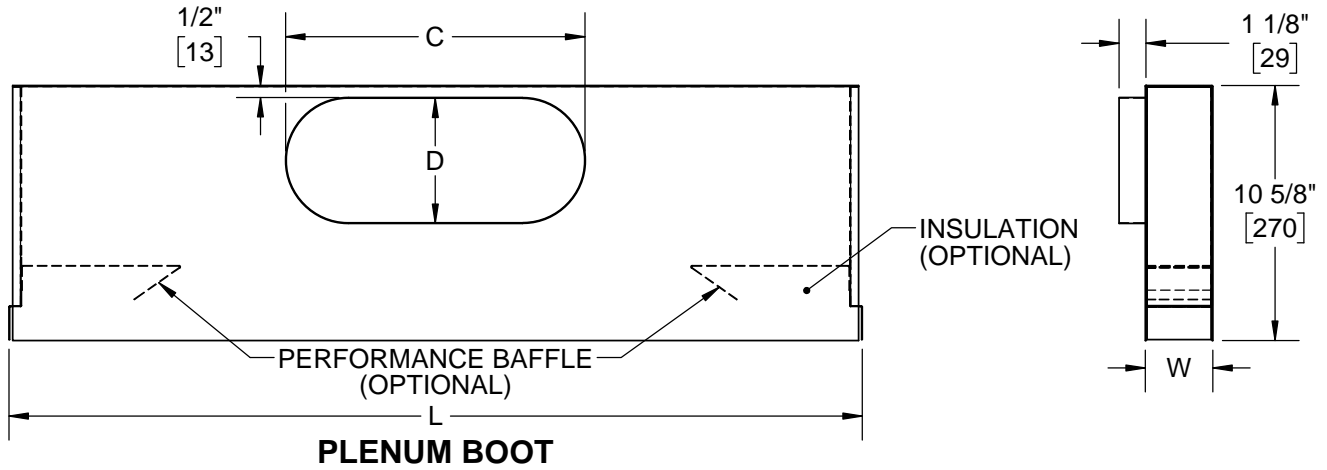

**1900 BOOT**

Tech Zone Plenum Boot - Frames N, S

**SUBMITTAL SHEET**

NOMINAL LENGTH	L
24 (610)	23 1/8 (587)
30 (762)	29 1/8 (740)
36 (914)	35 1/8 (892)
48 (1219)	47 1/8 (1199)
60 (1524)	59 1/8 (1502)
72 (1829)	71 1/8 (1807)

INLET	C	D
6" OVAL	6 1/4 (159)	5 1/4 (133)
8" OVAL	9 3/8 (238)	
10" OVAL	12 1/2 (318)	
12" OVAL	15 5/8 (397)	7 7/8 (200)

NUMBER OF SLOTS	W
1	1 7/16 (37)
2	2 11/16 (68)
3	4 1/8 (105)
4	5 7/16 (138)

**FEATURES:**

- 1) 24 GA. Galvanized Steel Construction
- 2) Mill Finish is Standard

**NOTES:**

- End Caps are Not Insulated (Standard)
- See Form DS0710 For End Treatment and Length Details
- Insulation options Not Available with Inlet Size RR
- Dimensions are shown as inches [MM]

**OPTIONS:**

- Inlet Damper (Ships Separately for Field Attachment)
- Internal 1/4", 2 lb Density Fiberglass Insulation
  - Insulated End Caps
- External Foil Encapsulated 1/2", 1 1/2 lb Density Fiberglass Insulation
- Internal Closed Cell Insulation 3/8"
  - Insulated End Caps
- Performance Baffles

Revision Date: 8/15

Form: DS0716.5

Replaces: DS0716.3

Product Information is Subject to Change Without Notice