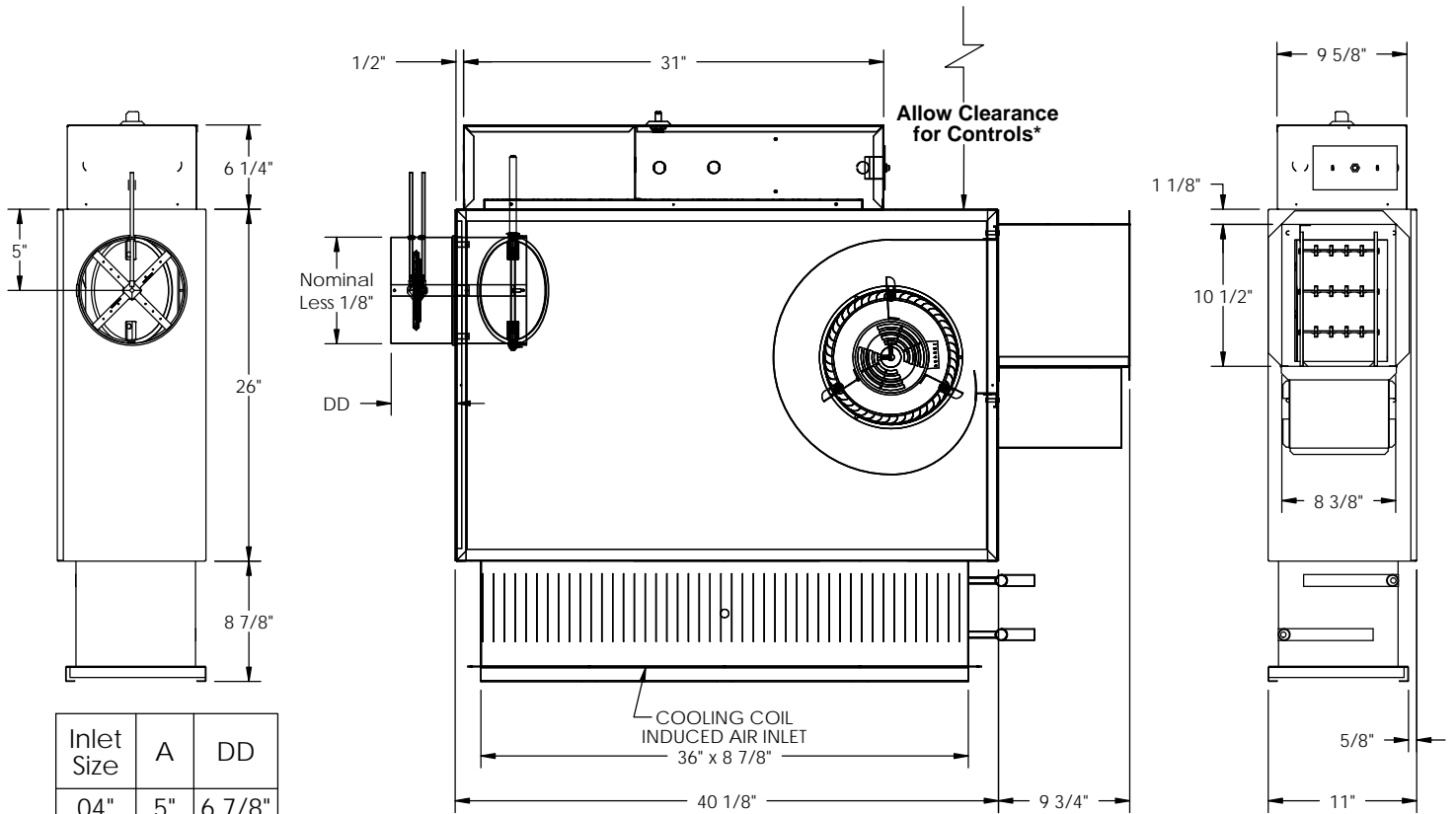

KLPS-D Unit 3
Electric Heat with Electronic Controls
SUBMITTAL SHEET

Inlet Size	A	DD
04"	5"	6 7/8"
05"	5"	6 7/8"
06"	5"	4 7/8"
07"	6"	4 7/8"
08"	6"	4 7/8"

PLAN VIEW - LEFT HAND UNIT
 (Downstream Side Induced Coil Connection Shown)

INLET VIEW
DISCHARGE VIEW
STANDARD FEATURES:

- 20GA. Galvanized Steel Construction
- Steel Control Enclosure for Electronic Components
- 1/2" Thick Dual Density Fiberglass Insulation Meeting NFPA 90A and UL181 Safety Requirements
- 1/3 HP ECM Motor with Permanently Lubricated Ball Bearings and Constant Airflow Program
 - Manual Control 0-10Vdc Remote Control
 - 2-10Vdc Remote Control
 - 120V 208/240V 277V
- Bottom Access Panel for Service
- Sensible Cooling Coil Factory Installed on Induced Air Inlet Supplied with Drip Tray **
- 4 Quadrant, Center Averaging Inlet Flow Sensor
- Factory Supplied 24 Volt Control Transformer for Electronic Controls
- ETL Listed
- Performance Data per AHRI Standard 880
- Construction Type Air Filters – 18 1/2" x 10" x 1" x 2"
 - * Check NEC for Unit Clearance Requirements
 - ** See Submittal Form TUS03-135-000CP

OPTIONAL FEATURES:

- Liners
 - 1/2" Cellular Insulation No Liner
 - 1/2" Foil Encapsulated Fiberglass Insulation
 - Solid Metal Liner with 1/2" Dual Density Fiberglass
 - Perforated Metal Liner with 1/2" Dual Density Fiberglass
- Cooling Coil Connections
 - Upstream Side Downstream Side
- Linear Averaging Inlet Flow Sensor
- LineaHeat Controlled SSR Heat
 - Discharge Temperature Sensor
- 24VAC SSR Manual Reset Cutoff
- Left Hand Controls Right Hand Controls
- Motor Fusing Chicago Code
- Dust Tight Control Enclosure
- Door Interlocking Disconnect Switch:
 - Fused Non-Fused
- Hanger Brackets
- MERV 8 Air Filters – 18 1/2" x 10" x 1" x 2"
- Dual Access Panels for Service
 - Cam-Locks (Dual Access Panel Only)