



AFQ

### Introduction: AFQ

The *Krueger by Halton AFQ* provides a 90° discharge pattern which is well suited for corner installations with a curved face, the AFQ is able to handle high capacities at low sound levels. The detachable face facilitates cleaning of the internal baffle and duct connections.

#### MODEL

AFQ - Corner Round, Low-Velocity Supply Unit

#### FEATURES

- 20 gage front panel.
- Horizontal low velocity discharge at floor level.
- Corner installation with a 90° supply angle.
- Detachable front plate and removable baffle enables cleaning of the unit and duct work.
- Round duct connection with integral gasket on top or bottom of the diffuser.

#### OPTIONS

- Stainless steel (AISI 316) design.
- 16 gage front panel.
- Duct cover (solid or perforated).
- Installation base (2", 4", 6").
- Vinyl trim in white or black.
- Flat face.
- Metal trim (painted to match).

#### FINISHES

- Standard is Polyester Painted White (RAL 9010).
- Custom colors available.

### AFQ Application

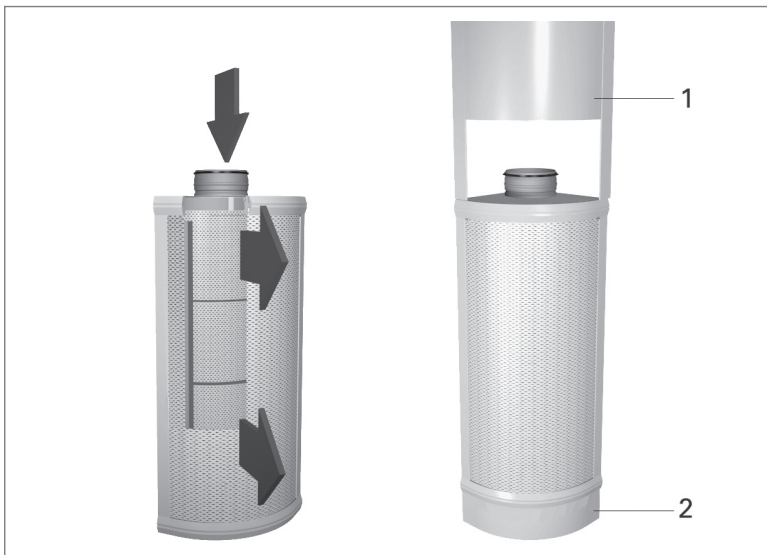

#### FUNCTION

Air is discharged into the space through the front panel of the unit, normally at a slightly lower temperature than setpoint.

The supply air flows at floor level and gradually pervades through the occupied space before rising due of the convection of warm surfaces.

The low velocity flow pattern is quarter-circular (90°).

*NOTES: The flow pattern data has been defined for floor installation. (1) Duct cover is for covering the duct work and is optional. (2) Installation base is used to raise the unit off the floor and is also optional.*

## AFQ Installation

### INSTALLATION EXPLODED VIEW

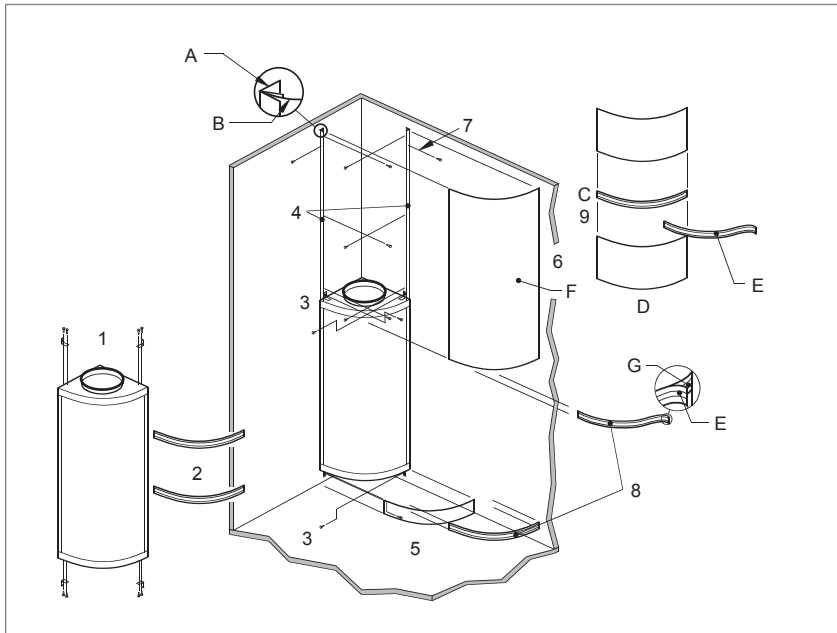

### INSTALLATION

Perform the installation in order.

1. Fix mounting brackets (4 places) to low velocity unit.
2. Remove trim (E) from unit.
3. Locate unit against wall and secure through mounting brackets.
4. Fix duct cover support brackets (A) to wall between unit and ceiling.
5. Position base against lower flange of the unit.
6. After installation of duct work, locate duct cover as follows: Locate duct cover section (F) on top flange (G) of unit and firmly push into support brackets fixed to wall (B).
7. Secure duct cover with screws through cover into support brackets.
8. Re-fit trim between duct cover and unit, and between base and unit by bending trim back on itself (E) and pressing bead into groove in flange (G).
9. When multiple sections of duct cover are used (D), an aluminium coupling flange (C) is needed.

### DUCT INSTALLATION

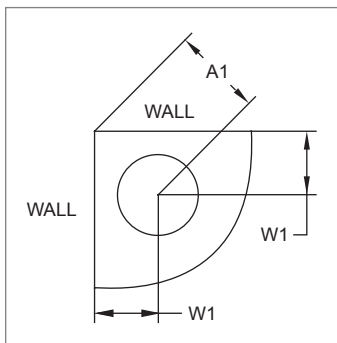

AFQ Size (Unit Size)	A1	W1
08"x23"	4 13/16"	3 7/16"
10"x23"	5 1/2"	3 7/8"
12"x31"	5 15/16"	4 3/16"
14"x47"	7 1/2"	5 5/16"
16"x47"	9"	6 3/8"
19"x59"	10 13/16"	7 5/8"
24"x71"	13 3/16"	9 5/16"
29"x71"	16 9/16"	11 3/4"
36"x71"	20 1/8"	14 3/16"

## AFQ Service & Maintenance

### SERVICING

Open the front panel (2) by first removing the trim (1) and unscrewing the screws. Pull out the front panel. If required, the internal baffle (3) can be detached by unscrewing the fixing screws. Pull out the inner structure. Clean the parts with a brush or damp cloth. After cleaning, reassemble in reverse order.

Code	Description
1	Trim
2	Front Panel
3	Internal Baffle
4	Assembly Brackets
5	Casing

