



AFP

Introduction: AFP

The Krueger by Halton AFP provides a rounded high capacity, 180° discharge pattern with low occupied zone velocities. The half circle face is ideal for large supply areas requiring placement against a wall or as part of a pillar. The removable face facilitates cleaning of the internal baffle and duct connections.

MODEL

AFP - Half Round, Low-Velocity Supply Unit

FEATURES

- 20 gage front panel.
- Horizontal low velocity discharge at floor level.
- Flow pattern at an angle of 180° enables large coverage with low residual velocities in the occupied zone.
- Detachable front plate and removable baffle enables cleaning of the unit and duct work.
- Round duct connection with integral gasket at the top or bottom of the diffuser.

OPTIONS

- Stainless steel (AISI 316) design.
- 16 gage front panel.
- Duct cover (solid or perforated).
- Installation base (2", 4", 6").
- Vinyl trim in white or black.
- Metal trim (painted to match).

FINISHES

- Standard is Polyester Painted White (RAL 9010).
- Custom colors available.

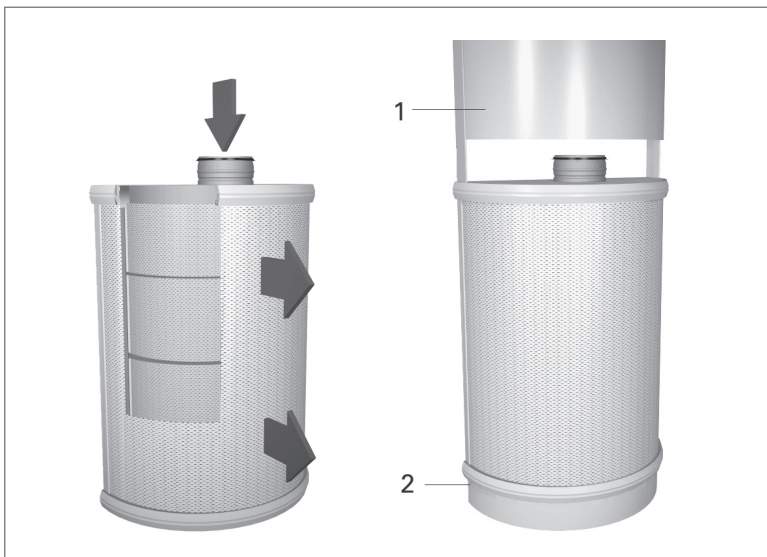
AFP Application**FUNCTION**

Air is discharged into the space through the front panel of the unit, normally at a slightly lower temperature than setpoint.

The supply air flows at floor level and gradually pervades through the occupied space before rising due to the convection of warm surfaces.

The low velocity flow pattern is semi-circular (180°).

NOTES: The flow pattern data has been defined for floor installation. (1) Duct cover is for covering the duct work and is optional. (2) Installation base is used to raise the unit off the floor and is also optional.

AFP Installation

INSTALLATION EXPLODED VIEW

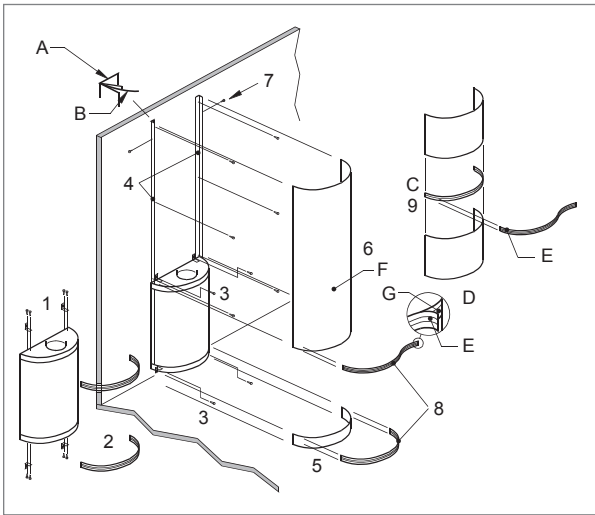

INSTALLATION

Perform the installation in order.

1. Fix mounting brackets (4 places) to low velocity unit.
2. Remove trim (E) from unit.
3. Locate unit against wall and secure through mounting brackets.
4. Fix duct cover support brackets (A) to wall between unit and ceiling.
5. Position base against lower flange of the unit.
6. After installation of duct work, locate duct cover as follows: Locate duct cover section (F) on top flange (G) of unit and firmly push into support brackets fixed to wall (B).
7. Secure duct cover with screws through cover into support brackets.
8. Re-fit trim between duct cover and unit, and between base and unit by bending trim back on itself (E) and pressing bead into groove in flange (G).
9. When multiple sections of duct cover are used (D), an aluminium coupling flange (C) is needed.

DUCT INSTALLATION

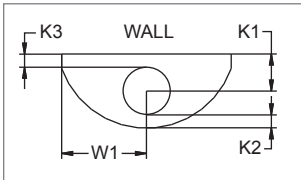

AFP Size (Nominal Dia x H)	W1	K1	K2	K3
14" x 23"	8 3/8"	3 5/8"	1 1/2"	1 5/8"
16" x 23"	9 1/2"	4"	1 9/16"	1 9/16"
20" x 31"	11 1/2"	4 13/16"	1 7/8"	1 5/8"

AFP Service & Maintenance

SERVICING

Open the front panel (2) by first removing the trim (1) and unscrewing the screws. Pull out the front panel. If required, the internal baffle (3) can be detached by unscrewing the fixing screws. Pull out the internal structure. Clean the parts with a brush or a damp cloth. After cleaning, reassemble in reverse order.

Code	Description
1	Trim
2	Front Panel
3	Internal Baffle
4	Assembly Brackets
5	Casing

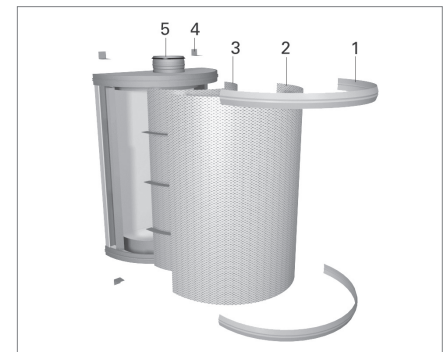

AFP Dimensional Information

AFP FRONT AND SIDE VIEWS

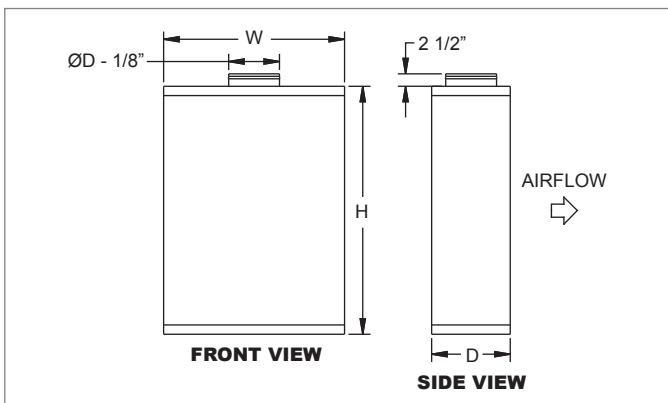

AFP DIMENSIONAL REFERENCES

AFP Size (Nominal Dia x H)	W	H	D	ØD
14" x 23"	16 11/16"	23 5/8"	7 5/16"	4"
16" x 23"	19 1/16"	23 5/8"	8 1/4"	5"
20" x 31"	23"	31 1/2"	10 1/16"	6"

AFP ADDITIONAL SIZES AVAILABLE

Nominal Dia.	H	ØD
18" Dia.	24", 36", 48"	10", 12"
24" Dia.	24", 36", 48", 60"	14", 16"
30" Dia.	24", 36", 48", 60"	14", 16"