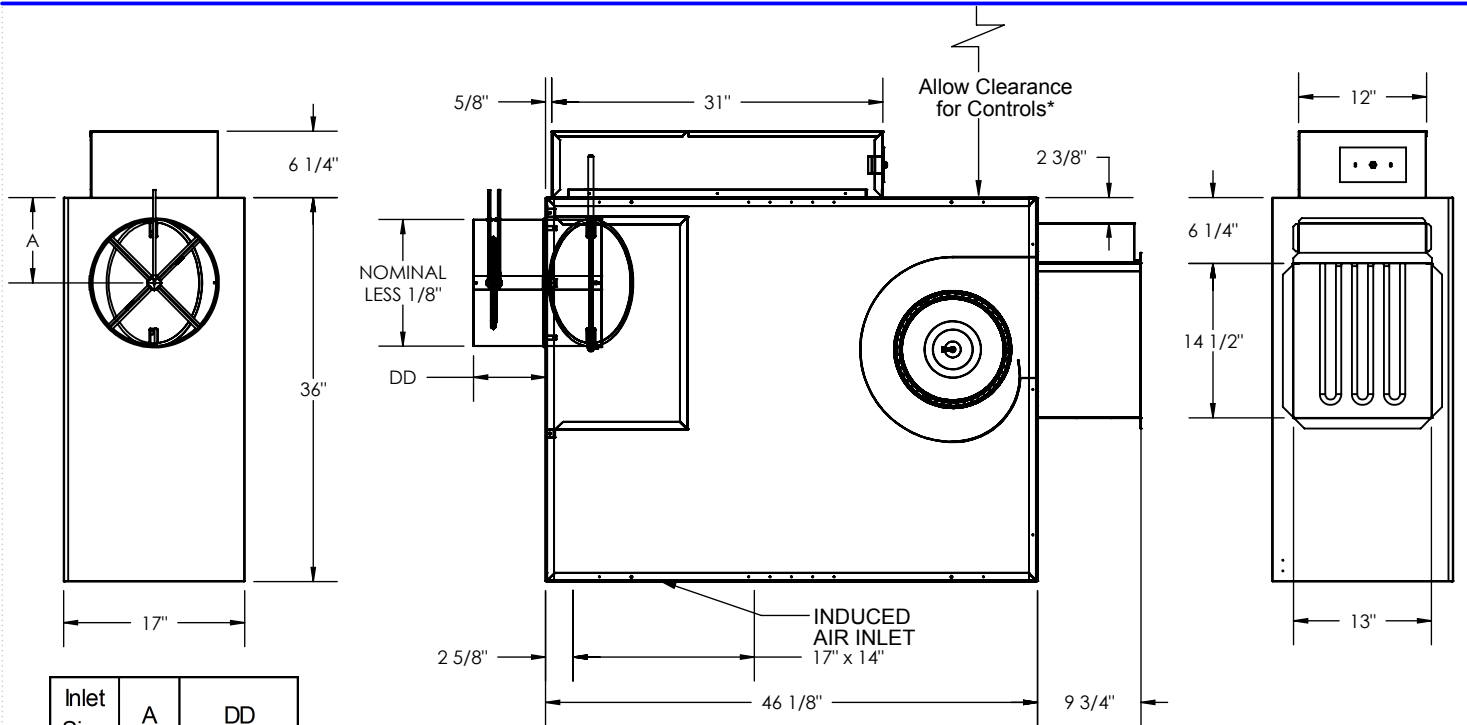

KLPS Unit Size 5
Electric Heat with Electronic Controls
SUBMITTAL SHEET

Inlet Size	A	DD
8"	6"	4 7/8"
10"	7"	4 7/8"
12"	8"	6 7/8"
14"	10"	6 7/8"

INLET VIEW
PLAN VIEW - LEFT HAND UNIT
DISCHARGE VIEW
STANDARD FEATURES:

- 20GA. Galvanized Steel Construction
- Steel Control Enclosure for Electronic Components
- 1/2" Thick Dual Density Fiberglass Insulation Meeting NFPA 90A and UL181 Safety Requirements
- 1/2 HP Single Speed, Single Phase, Permanently Lubricated PSC Motor
 - 120V 208/240V 277V
- Field Adjustable Speed Controller
- Bottom Access Panel for Service
- 4 Quadrant, Center Averaging Inlet Flow Sensor
- Factory Supplied 24 Volt Control Transformer for Electronic Controls
- ETL Listed
- Performance Data per AHRI Standard 880
- Variety of Direct Digital or Analog Electronic Control Packages Available

* Check NEC for Unit Clearance Requirements

OPTIONAL FEATURES:

- 1/2 HP ECM with Permanently Lubricated Ball Bearings and Constant Airflow Program
- Manual Control 0-10Vdc Remote Control
- 2-10Vdc Remote Control
- 120V 208/240V 277V
- Liners
 - 1/2" Cellular Insulation 1" Cellular Insulation No Liner
 - 1" Dual Density Fiberglass Insulation
 - 13/16" Steriliner Duct Board Insulation
 - Solid Metal Liner with 1/2" Dual Density Fiberglass
 - 1/2" Foil Encapsulated Fiberglass Insulation
 - 1" Foil Encapsulated Fiberglass Insulation
 - Perforated Metal Liner with 1/2" Dual Density Fiberglass
- Construction Type Air Filter – 19" x 16 1/2" x 1"
- Linear Averaging Inlet Flow Sensor
- LineaHeat Controlled SSR Heat
 - Discharge Temperature Sensor
- 24VAC SSR Manual Reset Cutoff
- Dust Tight Control Enclosure Motor Fusing
- Left Hand Controls Chicago Code
- Hanger Brackets Right Hand Controls
- Door Interlocking Disconnect Switch
 - Fused Non-Fused
- Dual Access Panels for Service
- Cam-Locks (Dual Access Panel Only)