

JOB NAME _____
 ARCHITECT _____
 ENGINEER _____
 CONTRACTOR _____
 LOCATION _____

SUBMITTAL SHEET
 Form Number GS0084.0 Effective Date 08/07
 NEW



**CRNLP / 5CRNLP – CONCENTRIC ROUND NOZZLE
 LAY-IN PANEL MOUNT (Frame 23)**

Note: The nominal size is 2" (51) smaller than the duct size it mounts to. Ex. A size 10 mounts on 12" (305) duct.

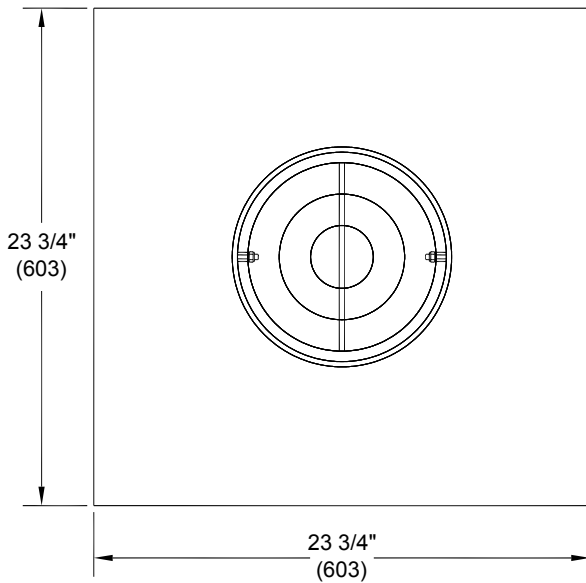

FACE VIEW

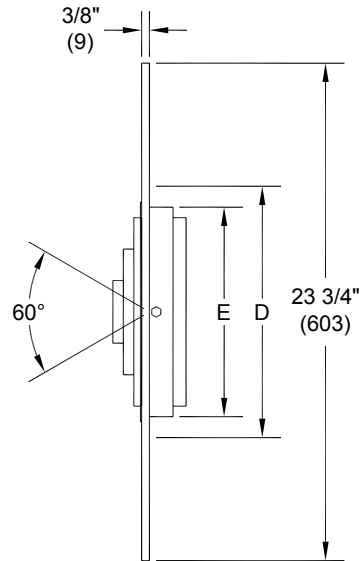

SIDE VIEW

NOMINAL SIZE	ELEMENT SIZE E	NUMBER OF RINGS	DUCT SIZE D
6	6" (152)	3	8" (203)
8	8" (203)	3	10" (254)
10	10" (254)	3	12" (305)
12	12" (305)	3	14" (356)
14	14" (356)	4	16" (406)

NOTE: DIMENSIONS ROUNDED TO THE NEAREST 1/16" (2)

DIMENSIONS ARE GIVEN AS
 INCHES (MM)

STANDARD FEATURES:

- CRNLP - Steel Construction
- 5CRNLP - Aluminum Construction

1. Easy Finger Tip Adjustment.
2. Directional Air Pattern Control
 60° Axis Adjustment
 ± 30° Deflection
 360° Rotation
3. Standard Finish is 44 White.
4. Other finishes are available.