

JOB NAME _____
 ARCHITECT _____
 ENGINEER _____
 CONTRACTOR _____
 LOCATION _____

SUBMITTAL SHEET
 Form Number GS0082.0 Effective Date 08/07
 NEW

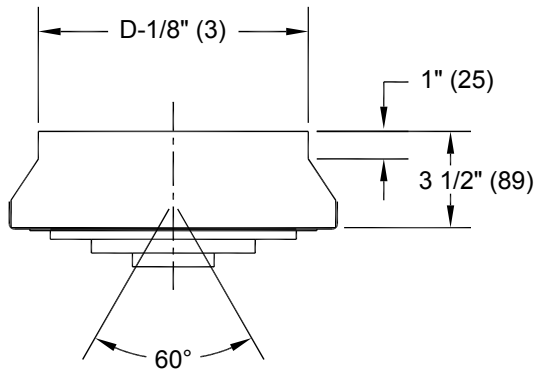

**CRNRR / 5CRNRR – CONCENTRIC ROUND NOZZLE
 ROUND REDUCER MOUNT**



SIDE VIEW

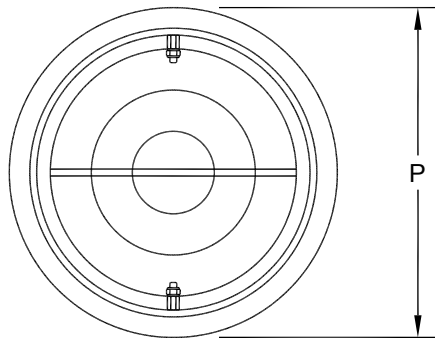

FACE VIEW

STANDARD FEATURES:

- CRNRR - Steel Construction
- 5CRNRR - Aluminum Construction

1. Easy Finger Tip Adjustment.
2. Directional Air Pattern Control
60° Axis Adjustment
± 30° Deflection
360° Rotation
3. All units include Mounting Screws.
4. Adaptor is constructed of Aluminum.
5. Standard Finish is 44 White.
6. Other finishes are available.

**DIMENSIONS ARE GIVEN
 AS INCHES (MM)**

NOMINAL SIZE	ELEMENT SIZE	DUCT SIZE D	P
6	3" (76)	6" (152)	8 1/8" (206)
8	4 3/8" (111)	8" (203)	10 1/8" (257)
10	5 3/4" (146)	10" (254)	12 1/8" (308)
12	7 3/8" (187)	12" (305)	14 1/8" (359)
14	8 5/8" (219)	14" (356)	16 1/8" (410)
16	9 3/4" (248)	16" (406)	18 1/8" (460)
18	10 1/2" (267)	18" (457)	20 1/8" (511)

NOTE: DIMENSIONS ROUNDED TO THE NEAREST 1/16" (2)