

JOB NAME _____
 ARCHITECT _____
 ENGINEER _____
 CONTRACTOR _____
 LOCATION _____

SUBMITTAL SHEET
 Form Number GS0080.0 Effective Date 08/07
 NEW

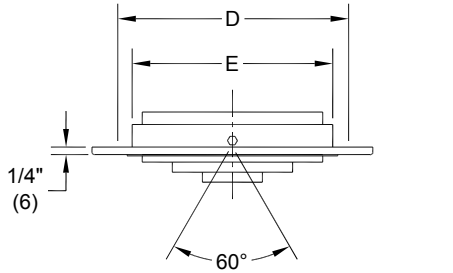

**CRN / 5CRN – CONCENTRIC ROUND NOZZLE
 SURFACE MOUNT**



SIDE VIEW

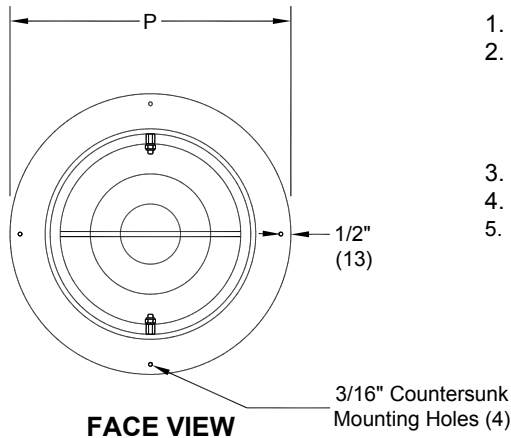

FACE VIEW

Note: The nominal size is 2" (51) smaller than the duct size it mounts to. Ex. A size 10 mounts on 12" (305) duct.

STANDARD FEATURES:

- CRN - Steel Construction
 - 5CRN - Aluminum Construction
1. Easy Finger Tip Adjustment.
 2. Directional Air Pattern Control
60° Axis Adjustment
± 30° Deflection
360° Rotation
 3. All units include Mounting Screws.
 4. Standard Finish is 44 White.
 5. Other finishes are available.

NOMINAL SIZE	ELEMENT SIZE E	NUMBER OF RINGS	DUCT SIZE D	P
4	4" (102)	3	6" (152)	8" (203)
6	6" (152)	3	8" (203)	10" (254)
8	8" (203)	3	10" (254)	12" (305)
10	10" (254)	3	12" (305)	14" (356)
12	12" (305)	3	14" (356)	16" (406)
14	14" (356)	4	16" (406)	18" (457)
16	16" (406)	4	18" (457)	20" (508)
18	18" (457)	4	20" (508)	22" (559)
20	20" (508)	5	22" (559)	24" (610)
22	22" (559)	5	24" (610)	26" (660)
24	24" (610)	5	26" (660)	28" (711)

DIMENSIONS ARE GIVEN AS INCHES (MM)

NOTE: DIMENSIONS ROUNDED TO THE NEAREST 1/16" (2)