



VPQ-0 & VPQ-4
The VPQ series of VAV diffusers feature a square plaque face with a choice of thermal or no controls.

VAV DIFFUSER APPLICATION & ENGINEERING INTRODUCTION..... A3-3

VPQ-0 & VPQ-4

Introduction A3-6
VAV, Dimensional Information, Frame Styles, & Accessories A3-7
VAV, Reference Charts & Performance Data..... A3-8
Constant Volume, Dimensional Data & Frame Styles..... A3-10
Constant Volume, Reference Charts & Performance Data A3-11
Engineering Specifications..... A3-13

VAV Diffuser Introduction

With the introduction of VAV systems into the air conditioning industry many years ago, varying supply air volumes (at constant temperature) in response to room load variations became the accepted method of conditioning many types of spaces. There was concern; however, that the reduction of air volumes would result in insufficient room air motion.

The ASHRAE comfort Standard (currently 55-2004) clearly states there is no minimum air motion required for occupant comfort, as long as the local temperature is uniform and properly controlled. Subsequent research has shown that the primary driver of room air motion at reduced loads, which is prevalent in most spaces, is driven by convective air currents created by the loads themselves.

Maintaining uniform temperatures at reduced, varying loads is a challenge to diffuser design and layout. Equally as challenging is to satisfy large temperature control zones without limiting the ability of occupants to have control of their environments.

ONE SOLUTION:

Variable Geometry VAV Diffusion Equipment (VGD)

With the introduction of variable geometry VAV diffusers (VGD), diffuser layout is simplified. A system can operate effectively over a broader range of space loads with smaller sized control zones. Due to a growing need to conserve energy, designers have in the past used VAV systems as the most economical and efficient solution to the problems posed by the multi-zone requirements of modern buildings. VGD systems are able to overcome limitations often imposed by these fixed geometry systems, while significantly decreasing the size of local control zones.

Types of VAV Systems (Refer to diagrams below.)

1. VAV systems that control the volume of supply air at the point of entry into the room. (Figure 1)
2. VAV systems that control the volume of supply air further upstream in the system, such as in a mixing terminal unit or duct. (Figure 2)

FIGURE 1

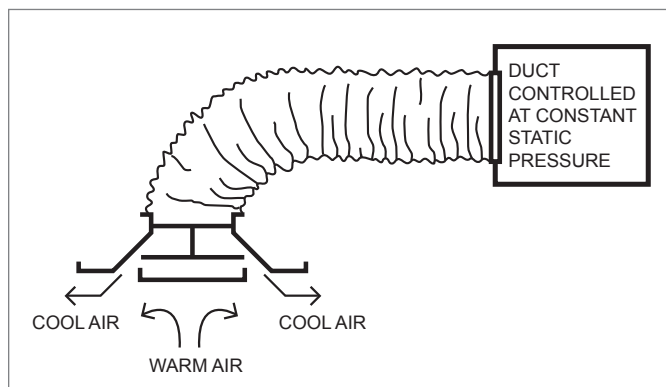

© KRUEGER 2012

In many cases, the first group may be more efficient and therefore more desirable. A modern VGD design ensures acceptable supply air distribution and uniform temperature control when supplying as little as 30% of the maximum airflow. Traditional VAV systems utilize an air volume control device that is located a considerable distance upstream of the room air diffusion unit. Because of this, those systems may not be able to take advantage of the higher leaving air velocities that result with VGD devices, which can be effective over a greater area at low delivery rates.

With conventional fixed geometry diffusers at reduced flows, cold air may drop into a space (often referred to as “dumping”), which may result in high temperature variability in a space - both vertically and laterally. Systems such as these are seldom a problem in internal zones or other applications which do not exhibit large load variations, such as shops with relatively constant internal heat gains. When loads may vary significantly or where smaller control zones are desirable, VGD systems may offer a performance advantage.

VAV System Design

Generally, the design considerations governing constant volume air conditioning systems may be applied to the design of air handling and air distribution equipment for variable volume systems. While the subjects of heat loads, air quantity, and temperature calculations are fully explained in such publications as the ASHRAE Handbooks, the following general procedures are suggested:

1. Cooling and heating load calculations are made for every module or zone in the building so that individual maximum and simultaneous maximum cooling/heating requirements and air quantities may be established.
2. The design temperature of supply air at the diffuser (allowing for all normally calculated extraneous gains such as fan heat and duct wall heat pick-up) is achieved by conventional psychometric calculations.
3. Individual maximum module or zone air volumes are calculated using the maximum room sensible heat gain, temperature difference (between supply air temperature at the diffuser), and design space temperature. These air volumes are then used to select air diffusers.

FIGURE 2

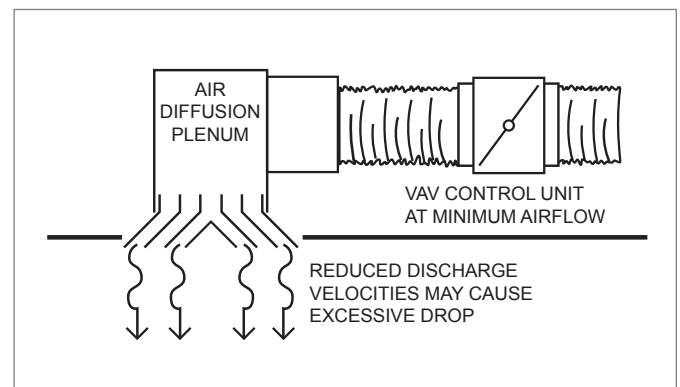

Introduction

VAV Diffuser Introduction

- Maximum simultaneous air supply and cooling requirements are then computed in order to establish the capacity of air handling units and central cooling equipment. Care must be taken during the design phase to ensure that ducts are adequately sized to convey the correct amount of air to every module or zone, under all conditions.

KRUEGER VGD SYSTEM DESIGN :**Control of Duct Pressure**

An essential requirement of variable volume systems is maintaining control of static pressure in supply air ducts within the design limits of the diffusers. Such control is easily achieved by a combination of the following methods, which is dependent on the size and configuration of the air distribution system:

- Control of fan output, within the supply air duct, by means of a static pressure regulator operating in conjunction with its capacity modulation device. In smaller systems, this device does not need to be more than a good vortex damper; although, acceptable performance will probably be achieved with a face and bypass damper configuration.
- Divide the air distribution systems into the most conveniently selected low pressure supply duct zones (supplied from low/medium pressure main ducts or risers) by installing branch duct dampers that operate in conjunction with branch supply duct static pressure regulators.

Duct Static Pressure Variations

Design and manufacturing discrepancies in supply duct systems are largely compensated for by terminal volume adjustment in response to thermostat action. Tolerances of -10% to +20% in-duct static pressure will not materially affect correct functioning of variable volume diffusers. Under all terminal unit output conditions, duct pressure variations will be compensated for by temperature controllers, which react to an incorrect supply of air by terminal volume regulation. At minimum flow, variations in duct static pressure are normally slight as duct pressure losses at low airflow are almost non-existent.

Recommended Branch Duct Pressure

The determination of design branch duct pressure should be governed by the following:

- The noise levels to be satisfied.
- The area the conditioned air should serve.
- The throw and the duct pressure needed to deliver the air flow required by thermal load calculations.

All of these details are provided in the relevant sections of this manual.

Recommended Main Duct or Riser Pressure

For economical fan operation, the pressure should be just high enough to accommodate main duct or riser pressure losses and design tolerances. With careful riser duct design, it should not be necessary to require that the riser or main duct pressure be more than 0.4" WG above branch duct pressure.

Positioning of Static Pressure Sensors

In all cases, static pressure sensors for branch ducts should be fitted in the branch ducts themselves and not in the feeder ducts to individual diffusers, nor in the diffusers themselves. Generally, it is recommended that static pressure sensors in branch ducts be fitted half-way between the duct pressure control damper or supply fan and at the end of the relevant duct so that the most representative pressure is sensed.

Branch Duct Velocities

In the case of branch ducts serving diffusers, it is recommended that conventional criteria be used in the determination of branch duct velocities. It is assumed that, depending on noise level requirements, these velocities will be in the range of (3.5-6m/s) 650 – 1200 ft/min. In some cases, slightly higher branch duct velocities are allowed because of the inherent noise attenuation properties of the diffusers with associated flexible duct connections. Generally, a maximum of (7.5m/s) 1500 ft/min is recommended. In the case of smaller fan coil type units (that incorporate light duty centrifugal fans), volume modulation can be achieved by installing supply duct restrictors and bypass dampers.

Cooling plants of the direct expansion type can be used for virtually every application and are generally cheaper to install and operate than chilled water generating plants. Limitations of cooling plants are imposed only by capacity. In the case of smaller plants, where cooling is controlled in only one or two steps, the temperature sensor for cooling control should be placed in the "warmest" room. This avoids short-cycling of the compressors, which would result if the off-coil temperature were to be measured and controlled.

Generally, individual reciprocating compressor cooling stations are limited to 45 tons capacity of refrigeration, above which, the economics of centrifugal or screw type chilled water generators begin to influence the choice.

A TYPICAL SYSTEM IN OPERATION WITH PRESSURE CONTROL DAMPERS Intelligent Comfort Control VAV Systems

In a well designed system, when heating is required, the cold air that is supplied to the terminal unit is in fact obtained "freely" by the economy cycle damper operation, which avoids unnecessary reheating of previously cooled air.

VAV Cooling / VAV Heating System

Through low-cost, modern technology, the action of the conventionally controlled Krueger VGD terminal equipment may be reversed, such that during the heating mode, a decrease in room temperature will cause an increased volume of preheated air to enter the occupant space. This is brought about automatically by the integral thermally actuated controller, which can detect that the supply air temperature entering the VAV unit is above a predetermined set point. In summary, through careful design and zoning considerations, the amount of reheat required could be substantially reduced without sacrificing flexibility or individual control.

VAV Diffuser Introduction

THE PRINCIPLE OF AIR FLOW MODULATION OF VARIABLE GEOMETRY TERMINALS

The diagram below (Figure 3) shows a supply air duct, a circular flexible connection and a Krueger VGD variable geometry VAV terminal unit.

FIGURE 3

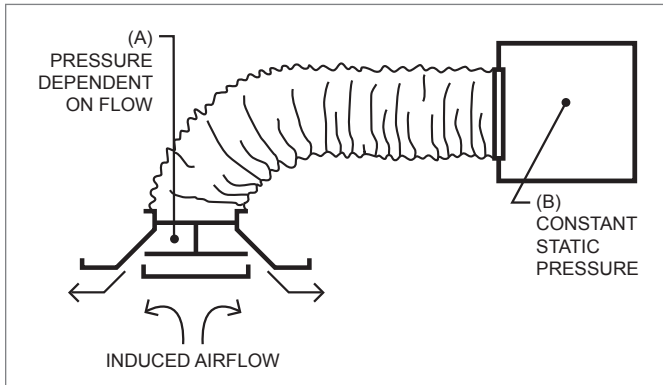

The terminal unit has a variable geometry air volume control device that activates in response to room temperature conditions. To modulate the airflow, the static pressure in duct “B” is controlled at a constant level while the variable geometry control device varies the aperture of the terminal unit. As a decreasing air volume flows from “B” to “A”, the resultant static pressure of “A” is increased. The increased static pressure at the lower flow rates is converted to velocity pressure, which results in an increased air velocity that enters the occupant space. Although mass flow at minimum supply air status is considerably reduced, the increased air velocity ensures long enough throw that room air distribution and temperature control are not compromised.

High Velocity System

Building space limitations may dictate the use of high velocity systems (at an operating cost premium) due to the resultant higher fan duties. At the point of change from high velocity, pressure reducing dampers are installed. Each damper unit requires a sound actuator to reduce high velocity duct and damper noise that is generated through pressure reduction.

Variable Geometry Terminal Unit Design

Having discussed overall design, we now consider the advantages of the Krueger VGD air diffusion concept. Essentially, the concept utilizes the principle of varying the shape of the diffusion device at the point of discharge into the occupant space. This ensures that acceptable air distribution patterns are maintained from minimum to maximum airflow conditions.



VPQ-4 backpan (left) and face view (right).

Introduction: VPQ

Room temperature is controlled by varying the supply air volume in accordance with demand. Volume control is achieved by moving a disc, known as the control disc, vertically up and down in the diffuser so as to vary the aperture through which air passes. This results in the “Variable Geometry” concept, which effectively maintains constant air movement in the room throughout the range of control, from 100% down to approximately 30% of design CFM.

The VPQ architectural VAV ceiling diffuser provides the building designer with the desired appearance and superior performance of a uniform 360° radial horizontal discharge air pattern that delivers even air throughout the space. The 24”x24” VPQ has a square faceplate made of one-piece, non-folded material with rounded corners, giving the diffuser a clean appearance that is unobtrusive to ceiling systems. The single faceplate gives the diffuser reduced pressure drops, a quiet sound profile, and is held in place by hooks that lock into the backpan. The one-piece, stamped backpan provides smooth, consistent corners, exacting dimensions, and performance tolerances.

MODEL

VPQ - Square Face, Architectural VAV Diffuser

FEATURES

- One-piece, non-folded, square face, steel construction.
- Removable faceplate offers easy duct access.
- Plaque face attaches to one-piece, stamped backpan.
- Various frame styles available.
- Thermal VAV controls or constant volume unit (no controls) available.
- Round inlet sizes: 6”, 8”, 10”, and 12”.

PANEL SIZE

- 24”x24”

OPTIONS

- VPQ-4: Thermal VAV controls.
- VPQ-0: Constant volume (no control).

ACCESSORIES

- Optional earthquake tabs.
- Optional relief ring. (VPQ-4 only.)

FINISHES

- Standard finish is #44 British White.

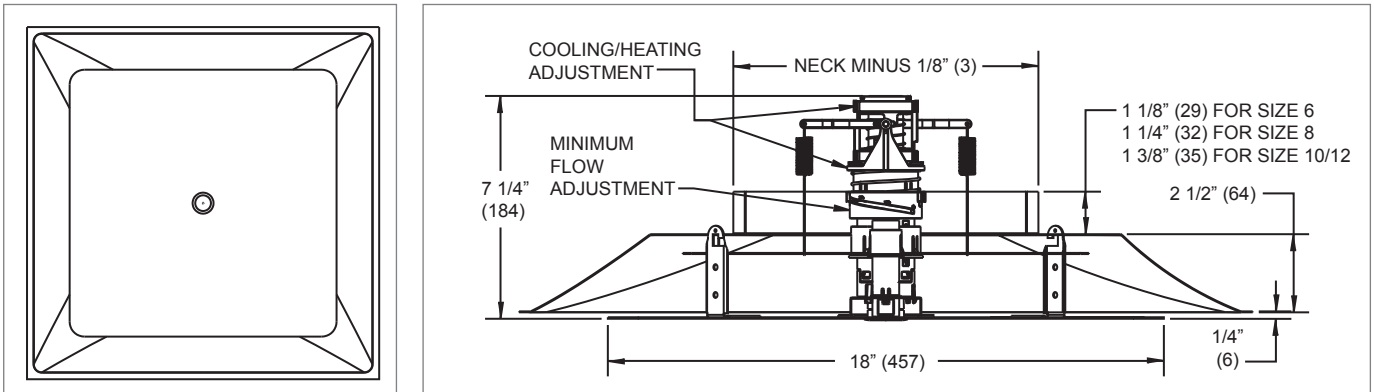
VPQ (Thermal VAV Controls) Dimensional Information
VPQ-4 FACE VIEW & SIDE VIEW

NOTES: A separate hard ceiling frame (model 5HCF23) is included with the F22, surface mount frame style.
All dimensions in parentheses are mm.

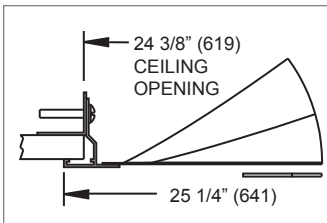
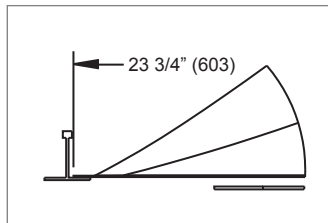
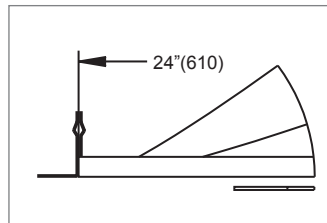
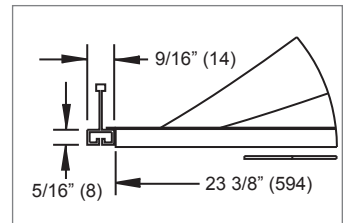
VPQ (Thermal VAV Controls) Frame Styles
**VPQ, FRAME 22,
24"x24" PANEL
SURFACE MOUNT**

**VPQ, FRAME 23,
24"x24" PANEL
LAY-IN T-BAR**

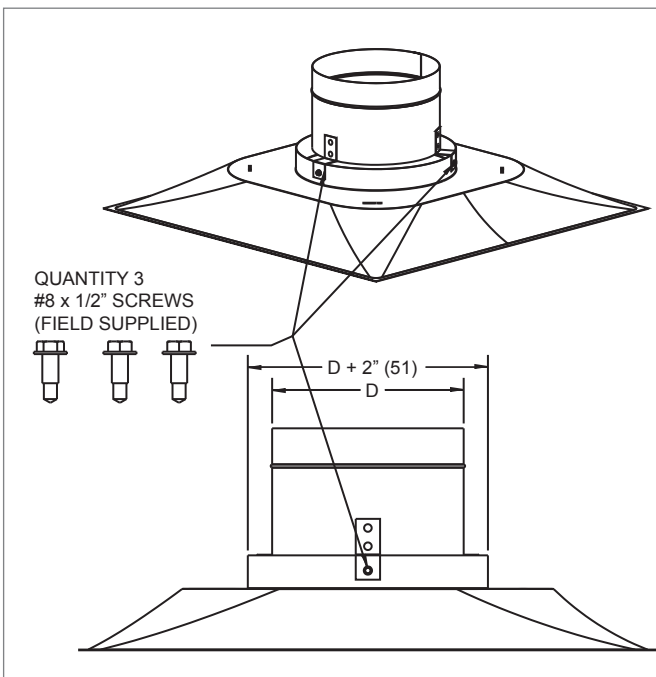
**VPQ, FRAME 24,
24"x24" PANEL,
SNAP-IN T-BAR**

**VPQ, FRAME 98,
24"x24" PANEL,
NARROW-T**

NOTES: A separate hard ceiling frame (model 5HCF23) is included with the F22, surface mount frame style.
All dimensions in parentheses are mm.

VPQ (Thermal VAV Control) Relief Ring Accessory
VPQ-4 RELIEF RING VIEWS

RELIEF RING PARTS & SIZING

| Part No. | D | D + 2" (51) |
|----------|--------------|-------------|
| 31636601 | 3 7/8" (98) | 6" (152) |
| 31636602 | 5 7/8" (149) | 8" (203) |
| 31636603 | 7 7/8" (200) | 10" (254) |
| 31636604 | 9 7/8" (251) | 12" (305) |

NOTES: Relief ring shipped separate for field installation. Diffuser neck must be upsized 2" (51) over ring size. All dimensions in parentheses are mm.

VPQ (Thermal VAV Control) Reference Charts: Horizontal Throw

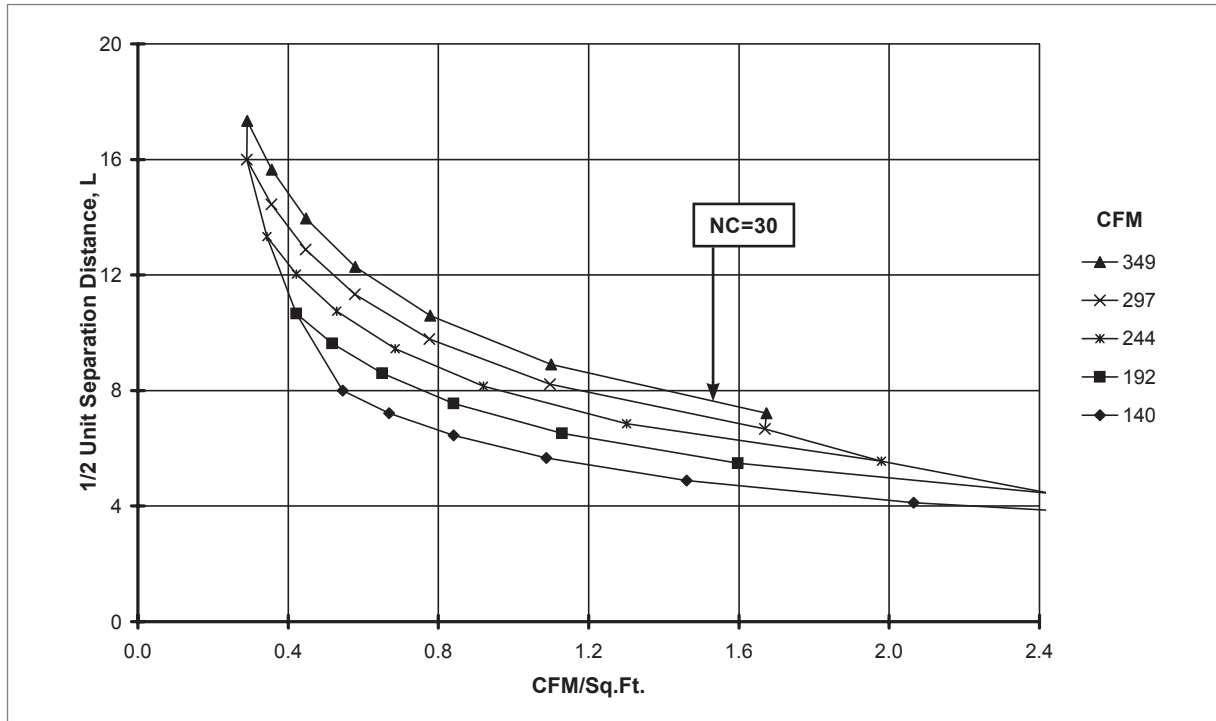
DIFFUSER SPACING FOR 80% ADPI: VPQ-4, 24"x24" PANEL, 8" NECK, 4-WAY (FULLY OPEN)



DIFFUSER SPACING FOR 80% ADPI: VPQ-4, 24"x24" PANEL, 12" NECK, 4-WAY (FULLY OPEN)

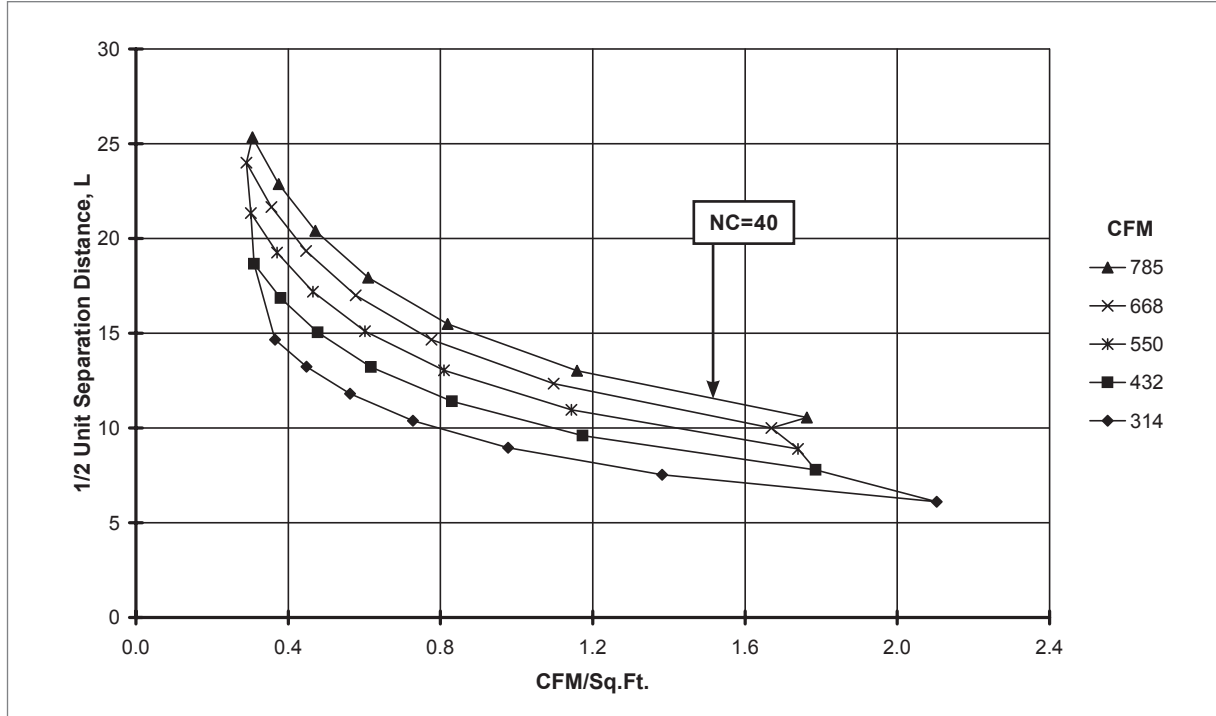

NOTES: Charts are at 20 BTUH/ft² loads. See the Engineering section of this catalog for instructions on how to read these charts and additional ADPI information.

VAV DIFFUSERS

VPQ

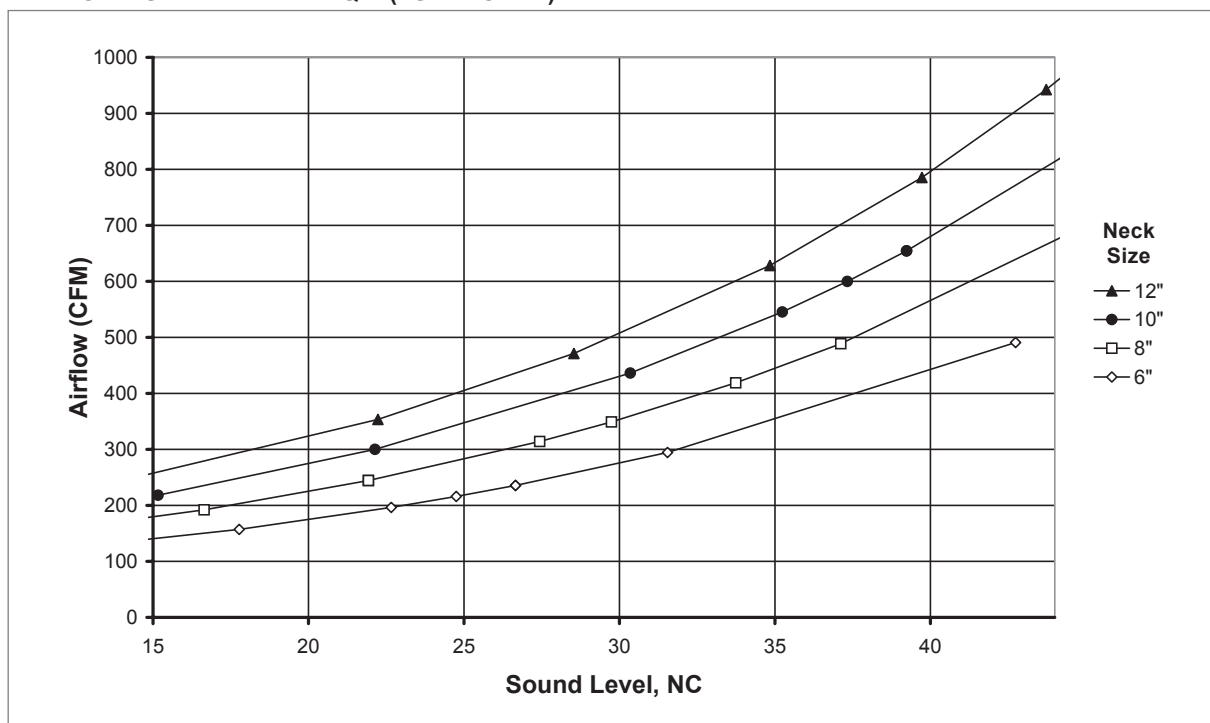
VPQ (Thermal VAV Control) Reference Charts: Horizontal Throw
AIRFLOW VS. NC LEVEL: VPQ-4 (FULLY OPEN)

VAV DIFFUSERS

VPQ (Thermal VAV Control) Performance Data
IP/METRIC DATA: VPQ-4, 24"x24" PANEL SIZE, MAXIMUM FLOW SELECTION (FULLY OPEN)

| | IP Data | | | | | NC | Metric Data | | | | | Octave Band, dB | | | | | |
|----------|----------|----------|--------|--------|-------------|----|-------------|----------|--------|--------|-----------------|-----------------|----|----|----|----|----|
| | Neck Vel | Air Flow | Min Ps | Min Pt | Throw | | Neck Vel | Air Flow | Min Ps | Min Pt | Throw | 2 | 3 | 4 | 5 | 6 | 7 |
| | FPM | CFM | "WG | "WG | ft | | m/s | L/s | Pa | Pa | m | | | | | | |
| 6" Dia. | 400 | 79 | 0.014 | .024 | 1 - 1 - 4 | - | 2.03 | 37 | 3.4 | 5.9 | 0.2 - 0.4 - 1.1 | 21 | 22 | 19 | 16 | - | - |
| | 550 | 108 | 0.026 | .045 | 1 - 2 - 5 | - | 2.79 | 51 | 6.5 | 11.2 | 0.4 - 0.7 - 1.5 | 27 | 28 | 25 | 22 | 14 | - |
| | 700 | 137 | 0.042 | .073 | 2 - 3 - 6 | 15 | 3.56 | 65 | 10.5 | 18.1 | 0.6 - 0.9 - 1.9 | 32 | 33 | 30 | 27 | 20 | - |
| | 850 | 167 | 0.062 | .107 | 2 - 4 - 7 | 19 | 4.32 | 79 | 15.4 | 26.6 | 0.8 - 1.1 - 2.3 | 36 | 37 | 34 | 31 | 24 | 13 |
| | 1000 | 196 | 0.086 | .148 | 3 - 4 - 9 | 23 | 5.08 | 93 | 21.4 | 36.9 | 0.9 - 1.3 - 2.7 | 39 | 40 | 37 | 35 | 27 | 17 |
| 8" Dia. | 400 | 140 | 0.023 | .033 | 2 - 3 - 6 | - | 2.03 | 66 | 5.6 | 8.1 | 0.5 - 0.9 - 1.8 | 28 | 30 | 26 | 22 | 14 | - |
| | 550 | 192 | 0.043 | .062 | 3 - 4 - 8 | 17 | 2.79 | 91 | 10.6 | 15.3 | 0.8 - 1.2 - 2.4 | 35 | 36 | 32 | 28 | 21 | 11 |
| | 700 | 244 | 0.069 | .100 | 3 - 5 - 10 | 22 | 3.56 | 115 | 17.2 | 24.8 | 1.0 - 1.5 - 3.1 | 40 | 41 | 37 | 33 | 26 | 16 |
| | 850 | 297 | 0.102 | .147 | 4 - 6 - 12 | 26 | 4.32 | 140 | 25.4 | 36.6 | 1.2 - 1.9 - 3.6 | 43 | 45 | 41 | 37 | 30 | 21 |
| | 1000 | 349 | 0.141 | .204 | 5 - 7 - 13 | 30 | 5.08 | 165 | 35.2 | 50.7 | 1.5 - 2.2 - 3.9 | 47 | 49 | 44 | 41 | 34 | 24 |
| 10" Dia. | 400 | 218 | 0.034 | .044 | 3 - 4 - 8 | 15 | 2.03 | 103 | 8.5 | 10.9 | 0.8 - 1.3 - 2.5 | 34 | 36 | 31 | 26 | 19 | - |
| | 550 | 300 | 0.064 | .083 | 4 - 6 - 11 | 22 | 2.79 | 142 | 16.0 | 20.7 | 1.1 - 1.7 - 3.4 | 40 | 43 | 37 | 33 | 26 | 17 |
| | 700 | 382 | 0.104 | .135 | 5 - 7 - 13 | 27 | 3.56 | 180 | 25.9 | 33.5 | 1.5 - 2.2 - 4.1 | 45 | 48 | 42 | 38 | 31 | 22 |
| | 850 | 464 | 0.153 | .199 | 6 - 9 - 15 | 32 | 4.32 | 219 | 38.2 | 49.4 | 1.8 - 2.7 - 4.5 | 49 | 52 | 46 | 42 | 35 | 26 |
| | 1000 | 545 | 0.212 | .275 | 7 - 10 - 16 | 35 | 5.08 | 257 | 52.9 | 68.4 | 2.1 - 3.1 - 4.9 | 52 | 55 | 49 | 46 | 39 | 30 |
| 12" Dia. | 400 | 314 | 0.048 | .058 | 4 - 5 - 11 | 20 | 2.03 | 148 | 11.9 | 14.4 | 1.1 - 1.6 - 3.3 | 39 | 41 | 35 | 30 | 23 | 15 |
| | 550 | 432 | 0.091 | .109 | 5 - 7 - 14 | 27 | 2.79 | 204 | 22.6 | 27.3 | 1.5 - 2.3 - 4.4 | 45 | 48 | 42 | 37 | 30 | 21 |
| | 700 | 550 | 0.147 | .177 | 6 - 9 - 16 | 32 | 3.56 | 259 | 36.5 | 44.1 | 1.9 - 2.9 - 4.9 | 50 | 53 | 46 | 42 | 35 | 27 |
| | 850 | 668 | 0.216 | .261 | 8 - 11 - 18 | 36 | 4.32 | 315 | 53.9 | 65.1 | 2.3 - 3.5 - 5.4 | 54 | 57 | 50 | 46 | 39 | 31 |
| | 1000 | 785 | 0.300 | .362 | 9 - 13 - 19 | 40 | 5.08 | 371 | 74.6 | 90.1 | 2.7 - 4.1 - 5.9 | 57 | 60 | 54 | 49 | 43 | 34 |

NOTES: Throw values are given for isothermal conditions and terminal velocities of 150, 100, and 50 FPM (0.75, 0.50, and 0.25 m/s). NC values are based on octave band 2 - 7 sound power levels minus a room absorption of 10dB, re 10⁻¹² Watts. Dash in space denotes a NC or dB value of less than 10. Data was obtained from tests conducted in accordance with ANSI/ASHRAE Standard 70. See Krueger's selection software for performance data not shown, including octave band data.

VPQ | Square Plaque Face, VAV Diffuser

VPQ (Constant Volume / No Control) Dimensional Information

VPQ-0 FACE VIEW

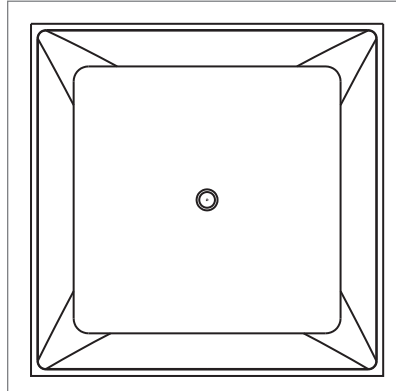

VPQ-0 SIDE VIEW

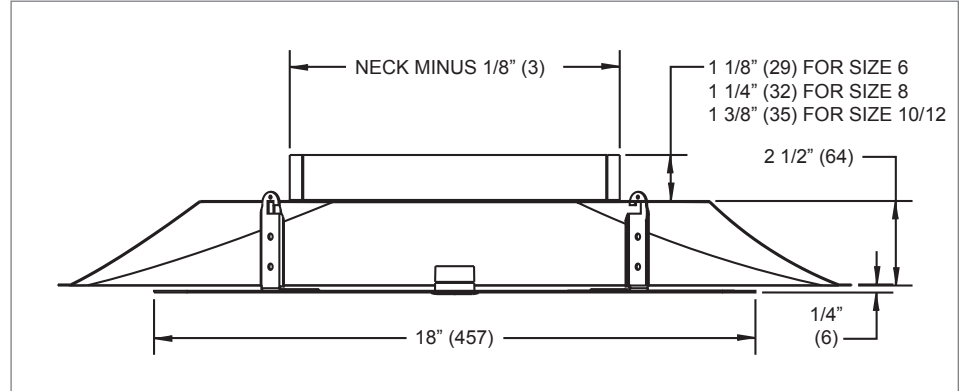

NOTE: All dimensions in parentheses are mm.

VPQ (Constant Volume / No Control) Frame Styles

VPQ, FRAME 22,
24"x24" PANEL
SURFACE MOUNT

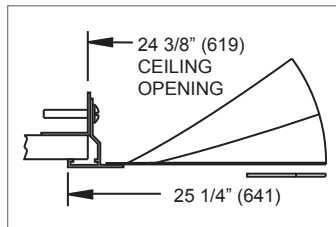

VPQ, FRAME 23,
24"x24" PANEL
LAY-IN T-BAR

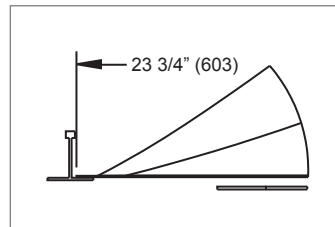

VPQ, FRAME 24,
24"x24" PANEL,
SNAP-IN T-BAR

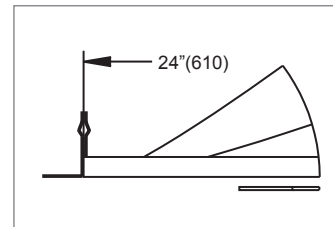

VPQ, FRAME 98,
24"x24" PANEL,
NARROW-T

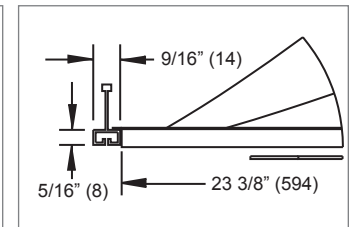

NOTES: A separate hard ceiling frame (model 5HCF23) is included with the F22, surface mount frame style. All dimensions in parentheses are mm.

VPQ (Thermal VAV Control or Constant Volume) Insert Dimensional Information

VPQ-0/VPQ-4 INSERT FACE VIEW

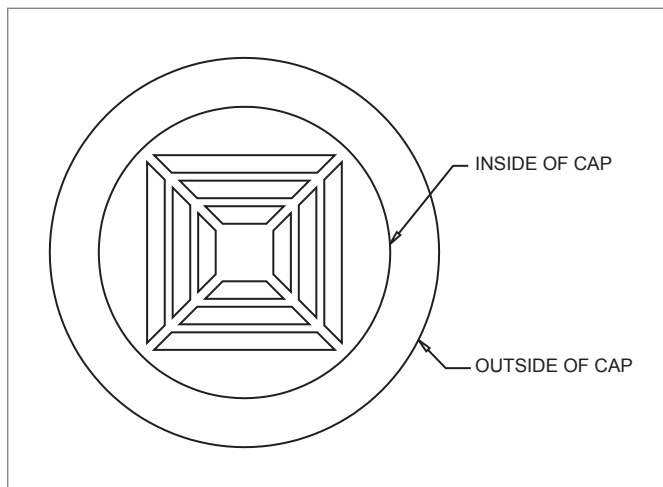

NOTE: Only available on VPQ-0 and VPQ-4.

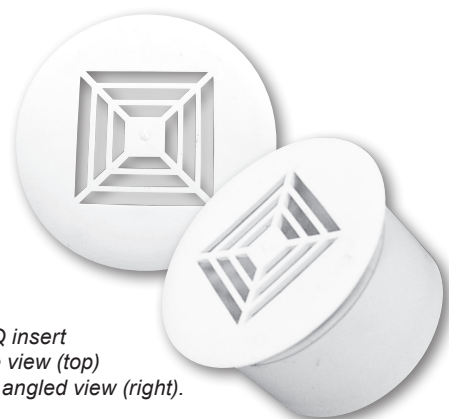

VPQ insert
face view (top)
and angled view (right).

VAV DIFFUSERS

VPQ

© KRUEGER 2012

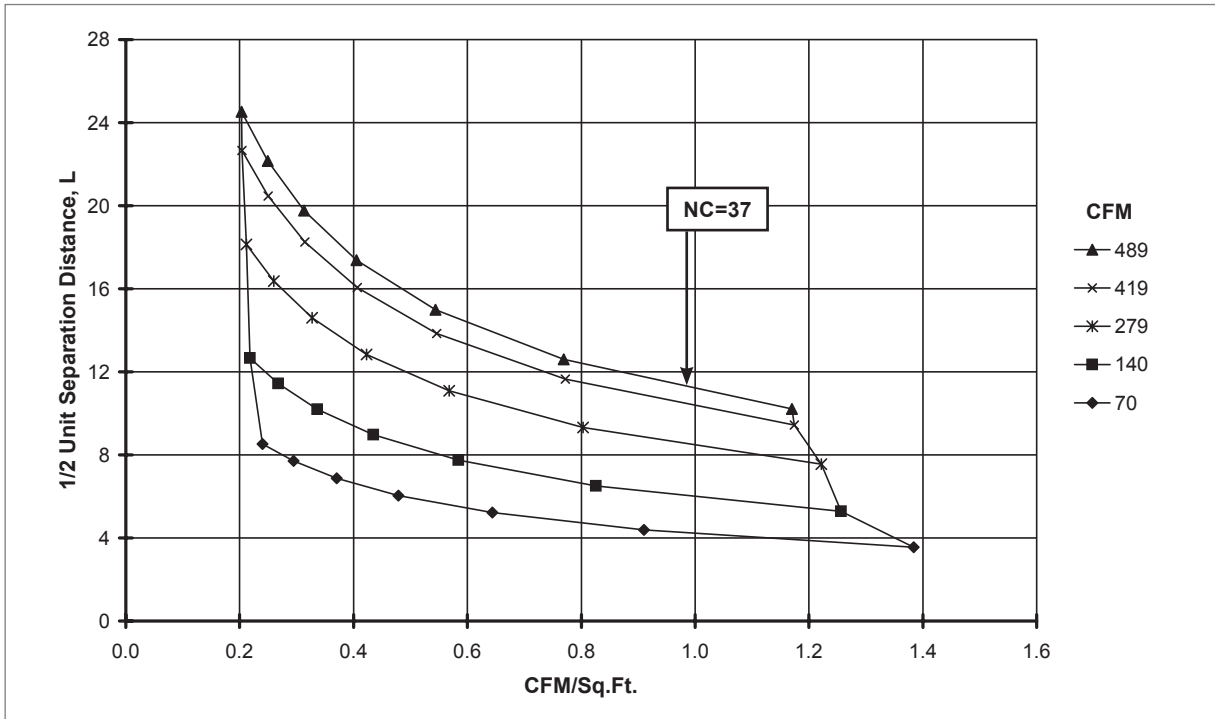
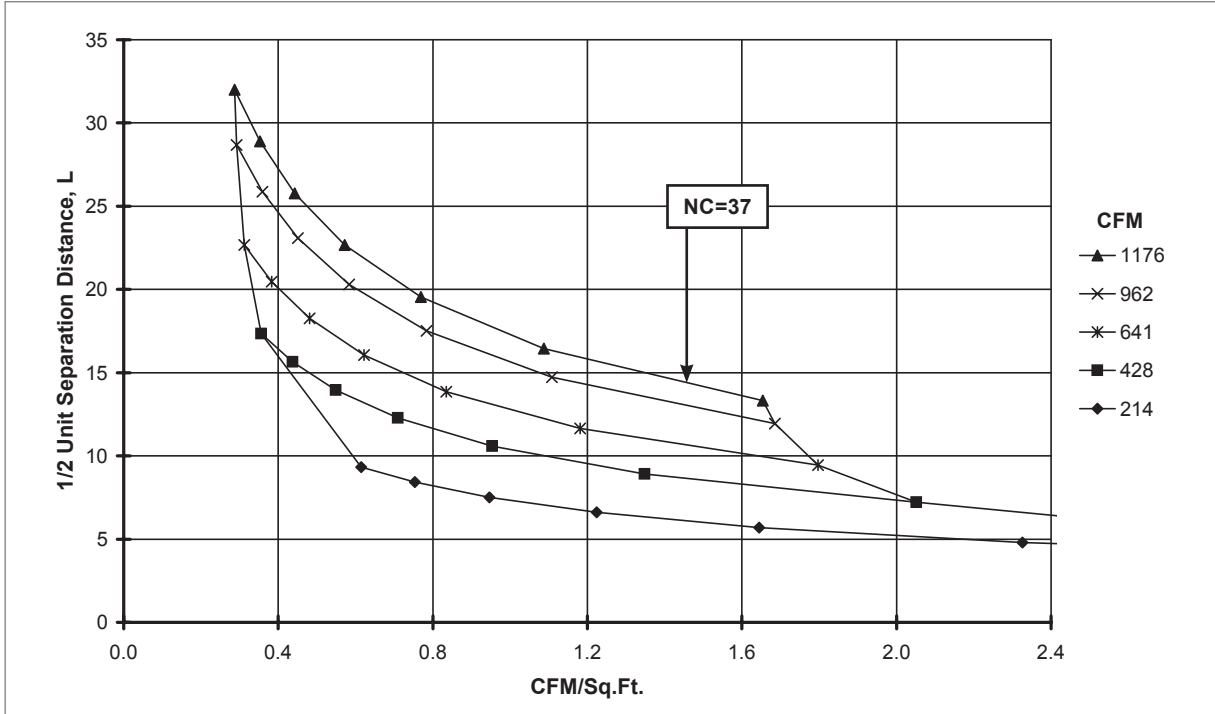
VPQ (Constant Volume / No Control) Reference Charts: Horizontal Throw
DIFFUSER SPACING FOR 80% ADPI: VPQ-0, 24"x24" PANEL, 8" NECK, 4-WAY (NO DAMPER)

DIFFUSER SPACING FOR 80% ADPI: VPQ-0, 24"x24" PANEL, 12" NECK, 4-WAY (NO DAMPER)

NOTES: Charts are at 20 BTUH/ft² loads. See the Engineering section of this catalog for instructions on how to read these charts and additional ADPI information.

VPQ (Constant Volume / No Control) Reference Chart: Horizontal Throw

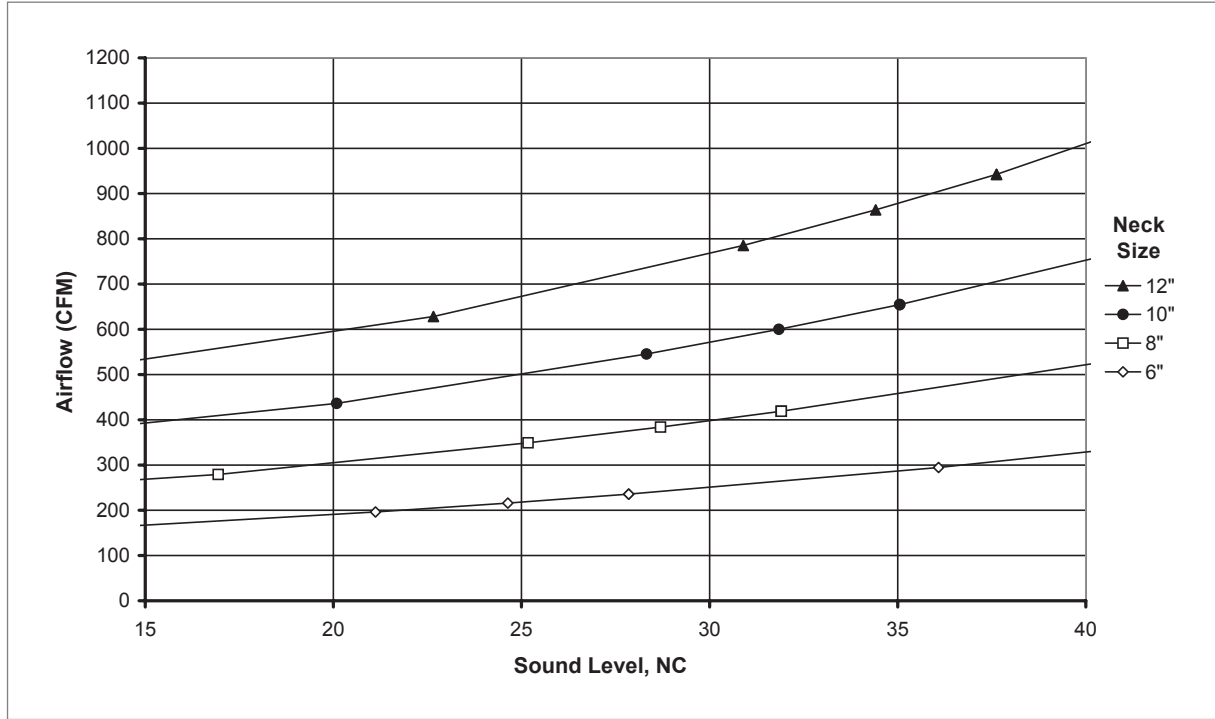
AIRFLOW VS. NC LEVEL: VPQ-0 (NO DAMPER)



VAV DIFFUSERS

VPQ (Constant Volume / No Control) Performance Data

IP/METRIC DATA: VPQ-0, 24"x24" PANEL SIZE (NO DAMPER)

| | IP Data | | | | | NC | Metric Data | | | | | Octave Band, dB | | | | | | |
|----------|----------|----------|-------|------|--------------|----|-------------|----------|------|------|-----------------|-----------------|----|----|----|----|----|--|
| | Neck Vel | Air Flow | Ps | Pt | Throw | | Neck Vel | Air Flow | Ps | Pt | Throw | Octave Band, dB | | | | | | |
| | FPM | CFM | "WG | "WG | ft | | m/s | L/s | Pa | Pa | m | 2 | 3 | 4 | 5 | 6 | 7 | |
| 6" Dia. | 200 | 39 | 0.000 | .003 | 0 - 0 - 1 | - | 1.02 | 19 | 0.1 | 0.7 | 0.0 - 0.1 - 0.4 | - | - | - | - | - | | |
| | 400 | 79 | 0.001 | .011 | 1 - 1 - 4 | - | 2.03 | 37 | 0.3 | 2.8 | 0.2 - 0.4 - 1.1 | 22 | 14 | - | - | - | | |
| | 600 | 118 | 0.002 | .025 | 1 - 3 - 5 | - | 3.05 | 56 | 0.6 | 6.2 | 0.4 - 0.8 - 1.6 | 33 | 27 | 23 | 11 | - | | |
| | 800 | 157 | 0.004 | .044 | 2 - 4 - 7 | 13 | 4.06 | 74 | 1.1 | 11.0 | 0.7 - 1.1 - 2.1 | 41 | 35 | 32 | 22 | 11 | | |
| | 1000 | 196 | 0.007 | .069 | 3 - 4 - 9 | 21 | 5.08 | 93 | 1.7 | 17.2 | 0.9 - 1.3 - 2.7 | 47 | 42 | 40 | 30 | 21 | | |
| | 1200 | 236 | 0.010 | .100 | 4 - 5 - 11 | 28 | 6.10 | 111 | 2.4 | 24.8 | 1.1 - 1.6 - 3.2 | 52 | 48 | 46 | 36 | 28 | 13 | |
| 8" Dia. | 200 | 70 | 0.002 | .004 | 0 - 1 - 3 | - | 1.02 | 33 | 0.5 | 1.1 | 0.1 - 0.3 - 0.9 | - | - | - | - | - | | |
| | 400 | 140 | 0.008 | .018 | 2 - 3 - 6 | - | 2.03 | 66 | 2.0 | 4.5 | 0.5 - 0.9 - 1.8 | 27 | 18 | 13 | - | - | | |
| | 600 | 209 | 0.018 | .040 | 3 - 4 - 9 | - | 3.05 | 99 | 4.5 | 10.1 | 0.9 - 1.3 - 2.6 | 38 | 30 | 26 | 15 | - | | |
| | 800 | 279 | 0.032 | .072 | 4 - 6 - 12 | 17 | 4.06 | 132 | 8.0 | 17.9 | 1.2 - 1.8 - 3.5 | 46 | 39 | 36 | 26 | 16 | | |
| | 1000 | 349 | 0.050 | .112 | 5 - 7 - 13 | 25 | 5.08 | 165 | 12.4 | 28.0 | 1.5 - 2.2 - 3.9 | 52 | 46 | 43 | 34 | 26 | 11 | |
| | 1200 | 419 | 0.072 | .162 | 6 - 9 - 14 | 32 | 6.10 | 198 | 17.9 | 40.3 | 1.8 - 2.6 - 4.3 | 57 | 52 | 49 | 41 | 33 | 20 | |
| 10" Dia. | 200 | 109 | 0.004 | .007 | 1 - 2 - 4 | - | 1.02 | 51 | 1.0 | 1.7 | 0.2 - 0.5 - 1.3 | 12 | - | - | - | - | | |
| | 400 | 218 | 0.017 | .027 | 3 - 4 - 8 | - | 2.03 | 103 | 4.2 | 6.7 | 0.8 - 1.3 - 2.5 | 31 | 21 | 15 | - | - | | |
| | 600 | 327 | 0.038 | .060 | 4 - 6 - 12 | - | 3.05 | 154 | 9.4 | 15.0 | 1.3 - 1.9 - 3.8 | 42 | 33 | 29 | 19 | - | | |
| | 800 | 436 | 0.067 | .107 | 5 - 8 - 14 | 20 | 4.06 | 206 | 16.8 | 26.7 | 1.7 - 2.5 - 4.4 | 49 | 42 | 38 | 29 | 20 | | |
| | 1000 | 545 | 0.105 | .168 | 7 - 10 - 16 | 28 | 5.08 | 257 | 26.2 | 41.8 | 2.1 - 3.1 - 4.9 | 55 | 49 | 45 | 37 | 30 | 17 | |
| | 1200 | 654 | 0.152 | .242 | 8 - 12 - 18 | 35 | 6.10 | 309 | 37.8 | 60.1 | 2.5 - 3.8 - 5.4 | 60 | 54 | 51 | 44 | 37 | 26 | |
| 12" Dia. | 200 | 157 | 0.007 | .009 | 1 - 3 - 5 | - | 1.02 | 74 | 1.7 | 2.3 | 0.3 - 0.8 - 1.6 | 15 | - | - | - | - | | |
| | 400 | 314 | 0.028 | .038 | 4 - 5 - 11 | - | 2.03 | 148 | 6.9 | 9.4 | 1.1 - 1.6 - 3.3 | 34 | 23 | 17 | - | - | | |
| | 600 | 471 | 0.062 | .085 | 5 - 8 - 15 | 12 | 3.05 | 222 | 15.5 | 21.1 | 1.6 - 2.5 - 4.6 | 45 | 36 | 31 | 21 | 11 | | |
| | 800 | 628 | 0.111 | .151 | 7 - 11 - 17 | 23 | 4.06 | 297 | 27.6 | 37.5 | 2.2 - 3.3 - 5.3 | 53 | 44 | 40 | 32 | 23 | 12 | |
| | 1000 | 785 | 0.173 | .236 | 9 - 13 - 19 | 31 | 5.08 | 371 | 43.1 | 58.6 | 2.7 - 4.1 - 5.9 | 59 | 51 | 47 | 40 | 33 | 22 | |
| | 1200 | 942 | 0.249 | .339 | 11 - 15 - 21 | 38 | 6.10 | 445 | 62.1 | 84.5 | 3.3 - 4.6 - 6.4 | 63 | 57 | 53 | 47 | 40 | 30 | |

NOTES: Throw values are given for isothermal conditions and terminal velocities of 150, 100, and 50 FPM (0.75, 0.50, and 0.25 m/s). NC values are based on octave band 2 - 7 sound power levels minus a room absorption of 10dB, re 10⁻¹² Watts. Dash in space denotes a NC or dB value of less than 10. Data was obtained from tests conducted in accordance with ANSI/ASHRAE Standard 70. See Krueger's selection software for performance data not shown, including octave band data.

V
P
Q

© KRUEGER 2012

VPQ Suggested Specification & Configuration

1. SERIES: (XXX)

VPQ - Steel VAV Diffuser with Square Backpan and Square Plaque Face

2. CONTROL: (X)

 0 - Constant Volume (No Controls)
 4 - Thermal (Wax) VAV Controls

3. INLET: (XX)

 06 - 6" Inlet
 08 - 8" Inlet
 10 - 10" Inlet
 12 - 12" Inlet

4. FRAME: (XXX)

 F22 - Surface Mount *
 F23 - Lay-in T-Bar
 F24 - Snap-in T-Bar
 F98 - Narrow-T

5. PANEL: (XX)x(XX)

24"x24"

6. ACCESSORIES: (XX)

 00 - No Accessories
 EQ - Earthquake Tabs

7. FINISH: (XX)

44 - British White

* Surface mount (F22) ships with a hard ceiling frame (5HCF23) for mounting.

VPQ-0: CONSTANT VOLUME DIFFUSER Furnish and install Krueger model VPQ constant volume architectural square panel ceiling diffusers of the sizes and mounting types shown on the plans or outlet schedule. The diffuser shall have a one piece square face plaque not exceeding 18"x18" for 24x24 panel size and be constructed of 16 gage steel with rounded corners that have a minimum radius of 3/4". Face plaques that have a secondary wrapper are not acceptable. The face plaque shall not extend below the ceiling more than 3/8" and shall be removable from the backpan for access to the optional damper. The diffuser backpan shall be one piece stamped construction of 22 gage steel and have an integrally drawn round neck.

VPQ-4: THERMAL VAV DIFFUSER

Furnish and install Krueger model VPQ thermally powered VAV diffusers with heating / cooling changeover. The diffuser shall be thermally powered to infinitely vary the supply of air into the space, in either heating or cooling mode, by means of regulating a variable aperture damper vertically within the diffuser. Supply air from the variable geometry diffusers will discharge horizontally in a 360° pattern and will maintain constant air movement in the space throughout the range of volume variation from 100% down to 30% of design CFM.

The thermal room sensing element shall be located behind an induction cap in the center of the diffuser panel and shall provide no more than 1°F thermal deadband between induced temperature and zone temperature.

Each diffuser shall be individually adjustable to sense room temperature within the space between 68°F and 77°F and be individually adjustable for minimum airflow from 0 to 30%. Each diffuser is to be fitted with a single thermal supply air sensing element to automatically change from and to a cooling and heating mode and be able to infinitely vary the supply of air into the space in either mode. Each diffuser shall be self-contained and require no external power source to maintain space temperature throughout the range of operation.

The diffusers shall be square panel type with an architectural square plaque face. The diffuser shall have a one piece square face plaque not exceeding 18"x18" for 24x24 panel size and be constructed of 16 gage steel with rounded corners that have a minimum radius of 3/4". Face plaques that have a secondary wrapper are not acceptable. The face plaque shall not extend below the ceiling more than 3/8" and shall be removable from the backpan for access to the digital components. The diffuser backpan shall be one piece stamped construction of 22 gage steel and have an integrally drawn round neck.

PERFORMANCE

The manufacturer shall provide published (printed or electronic) performance data for the diffuser. Performance data shall include 2 - 7 octave band sound power levels. The diffuser shall be tested in accordance to the data standards at the time of product introduction or ANSI/ASHRAE Standard 70.

FINISH

The paint finish shall be #44 British White and be an anodic acrylic paint, baked at 315°F for 30 minutes. The paint thickness shall be 0.8 – 1.0 mils, gloss at 60° per ASTM D523-89 of 50 – 85%, pencil hardness per ASTM D3363-92A of HB – H, crosshatch adhesion per ASTM D3359-83 of 4B – 5B, impact per ASTM D2794-93 of direct impact >100 in/lb and reverse impact >80 in/lb, salt spray per ASTM B117-9048 of 96 hours, humidity per ASTM D2247-92 of >500 hours and water soak per ASTM D870-92 of 250 hours.