

JOB NAME \_\_\_\_\_  
 ARCHITECT \_\_\_\_\_  
 ENGINEER \_\_\_\_\_  
 CONTRACTOR \_\_\_\_\_  
 LOCATION \_\_\_\_\_

**SUBMITTAL SHEET**  
 Form Number GSS018.1 Effective Date 05/13  
 REPLACES FORM: GSS018

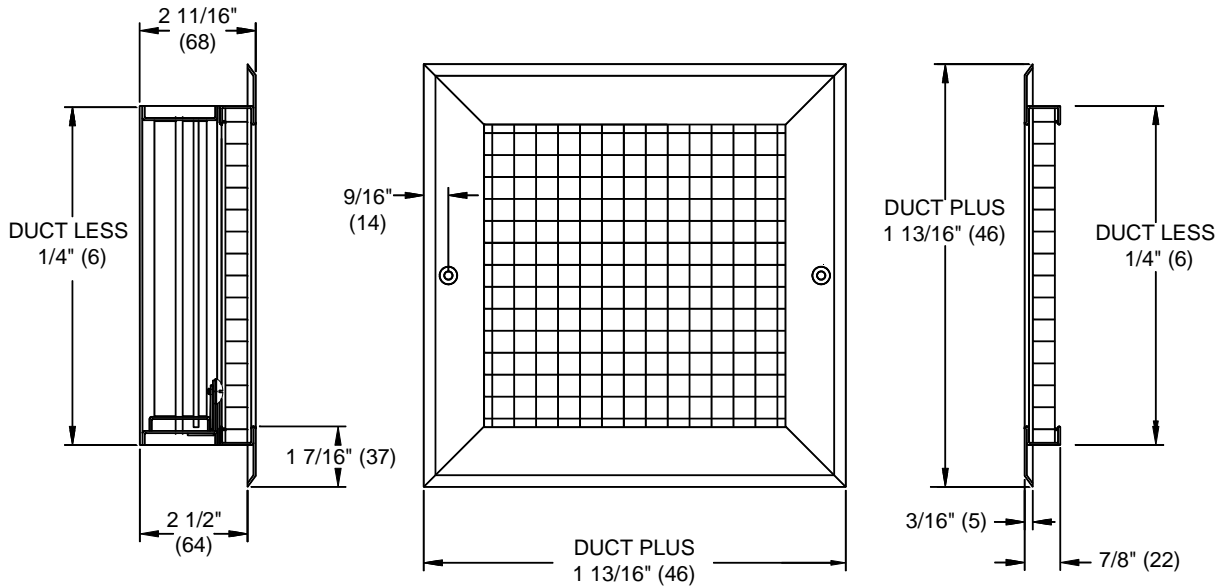

**9EGC5**  
**STAINLESS STEEL EGG CRATE GRILLE, 1/2" X 1/2" X 1/2" CORE**



**9EGC5**  
**FRAME 22 SHOWN w/ 9OBD**

**9EGC5**  
**FRAME 22**

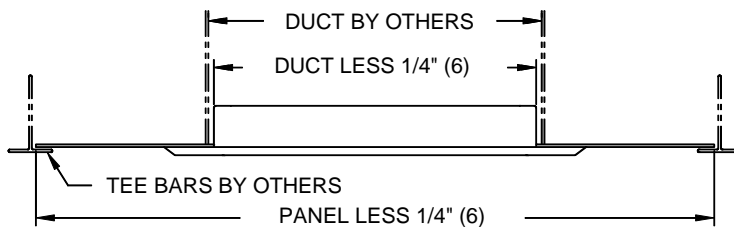

**FRAME 23 – SIDE VIEW**

**DIMENSIONS ARE GIVEN  
 AS INCHES (MM)**

**NOTES :**

1. FRAME CONSTRUCTION IS 20 GA. 304 STAINLESS STEEL.
2. CORE CONSTRUCTION IS 24 GA. 304 STAINLESS STEEL
3. AVAILABLE FRAME STYLES :  
 FRAME 22 – SURFACE MOUNT  
 FRAME 23 – LAY IN TEE BAR
4. STANDARD FINISH IS #3 SATIN POLISHED.

**OPTIONS :**

- TYPE 316 STAINLESS STEEL
- NO SCREWHOLES
- COUNTERSUNK SCREWHOLES WITH #6 x 1-1/4" STAINLESS STEEL SHEET METAL SCREWS
- 9OBD** - 20 GA STAINLESS STEEL OPPOSED BLADE DAMPER IS WELDED TO THE UNIT AND OPERATED BY A SCREWDRIVER.
- 9SRA** – SEE 9SRA SUBMITTAL