



TABLE OF CONTENTS

ARCHITECTURAL & PLAQUE DIFFUSERS



◀ **PRISM**
This supply diffuser features an arcuate faceplate. Center square appliqué offers nine standard colors to match interior décor.



◀ **PLQ & 5PLQ**
This supply diffuser features a square plaque faceplate.



◀ **PLQR**
This supply diffuser features a round plaque faceplate.



◀ **ASDT, 5ASDT, AVDT, & 5AVDT**
The ASD supply diffusers feature square ceiling tile faceplates. The AVD supply diffusers feature an integral, thermally powered thermostat with VAV control damper.



◀ **ASDP, 5ASDP, AVDP, & 5AVDP**
The ASD supply diffusers feature square plaque-style faceplates. The AVD supply diffusers feature an integral, thermally powered thermostat with VAV control damper.

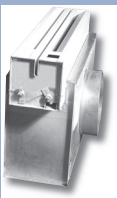

◀ **LVSD**
LVSD Series linear VAV supply diffuser features an aesthetic appearance with zone temperature control. Self contained and powered; requires no electrical wiring.

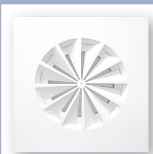

◀ **KSD**
This architectural supply diffuser features a center swirl.

MODEL PRISM

Introduction G-3
 Prism Dimensional & Appliqué Information G-4
 Prism Retrofit Installation Information G-5
 Prism Reference Charts G-6
 Prism Performance Data G-9
 Engineering Specification G-11

MODELS PLQ/5PLQ/PLQR

Introduction & Dimensional Information G-12
 PLQ/5PLQ/PLQR Frame Styles & Directional Blow Tabs G-13
 PLQ/5PLQ Reference Charts G-14
 PLQ/5PLQ Performance Data G-17
 PLQR Reference Charts G-19
 PLQR Performance Data G-22
 Engineering Specifications G-24

MODELS ASDP/5ASDP/ASDT/5ASDT

Introduction G-26
 ASDP/5ASDP/ASDT/5ASDT Dimensional Information & Adapter Frames G-27
 ASDP/5ASDP/ASDT/5ASDT Reference Charts G-28
 ASDP/5ASDP/ASDT/5ASDT Performance Data G-31
 Engineering Specifications G-33

MODELS AVDP/5AVDP/AVDT/5AVDT

Introduction G-34
 AVDP/5AVDP/AVDT/5AVDT Dimensional Information & Adapter Frames G-35
 Engineering Specifications G-36

MODELS LVSD

Introduction & Dimensional Information G-37
 Adapter Frame Information G-38
 Engineering Specifications G-39

MODEL KSD

Introduction & Dimensional Data G-40
 KSD Reference Charts G-41
 KSD Performance Data G-43
 Engineering Specification G-44



KSD | SWIRL DIFFUSER



▲ KSD

PANEL SIZE

- 24"x24"

KSD DIMENSIONAL INFORMATION

▼ KSD, FACE & SIDE VIEWS

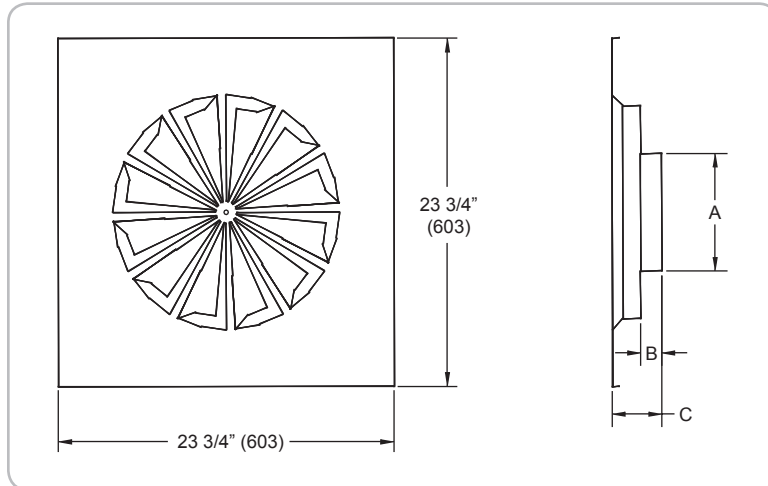

▼ KSD, AVAILABLE SIZES

Nominal Neck Size	A	B	C
6" (152)	5 7/8" (149)	1 1/2" (38)	3 1/2" (89)
8" (203)	7 7/8" (200)	1 1/2" (38)	3 1/2" (89)
10" (254)	9 7/8" (251)	1 1/2" (38)	3 1/2" (89)
12" (305)	11 7/8" (302)	1 1/4" (32)	3 1/4" (83)
14" (356)	13 7/8" (352)	1 1/2" (38)	3 1/2" (89)

► Dimensions in () are mm.

INTRODUCTION: KSD

This high induction diffuser promotes the rotation of room air which increases mixing effectiveness. The 360° horizontal discharge pattern works great in VAV applications where turndown requirements exceed 50% of maximum airflow for properly selected diffusers. The unique style of this diffuser will provide an aesthetically pleasing appearance to any architectural application. Offered in with a variety of neck sizes, the KSD can handle a wide range of airflows.

MODEL

MODEL KSD - Swirl Diffuser, Steel Construction

FEATURES

- For Use in Lay-in T-bar Applications
- High Capacity Airflow
- Aesthetically Pleasing Appearance

FINISHES

- Standard Finish is British White
- Optional Finishes Available



KSD REFERENCE CHARTS

▼ AIRFLOW VS. NC LEVEL: KSD (NO DAMPER)

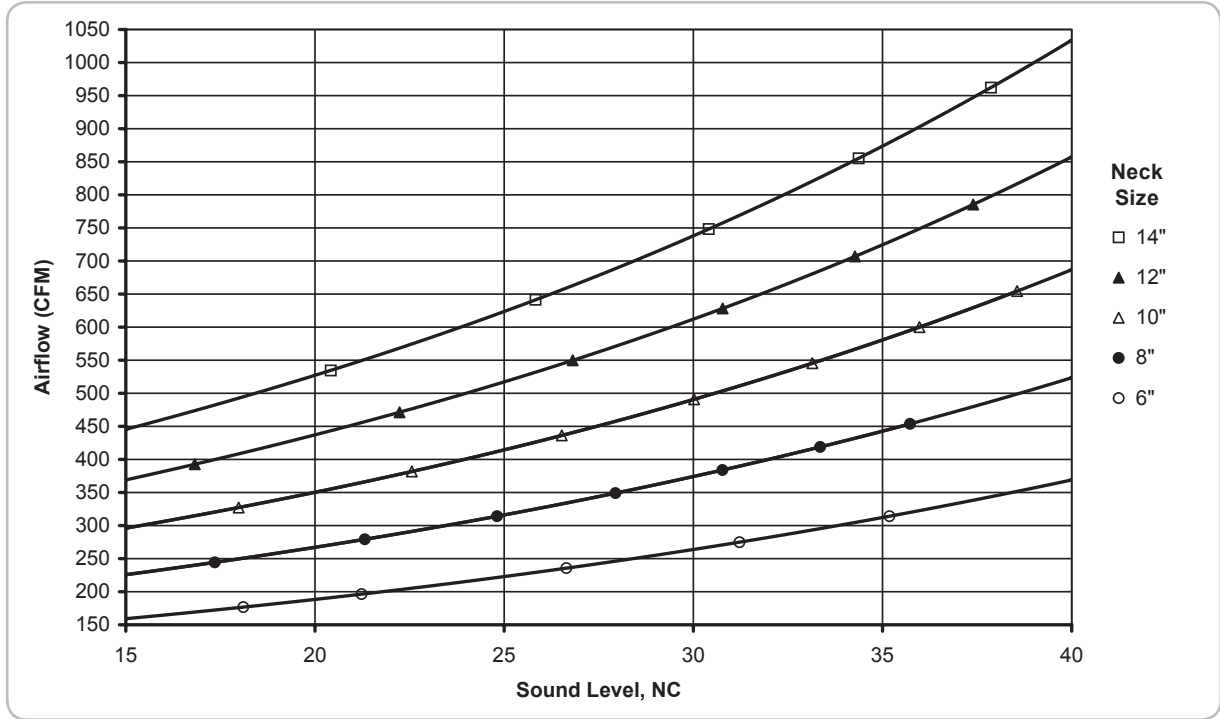

▼ DIFFUSER SPACING FOR 80% ADPI: KSD, 6" NECK (NO DAMPER)

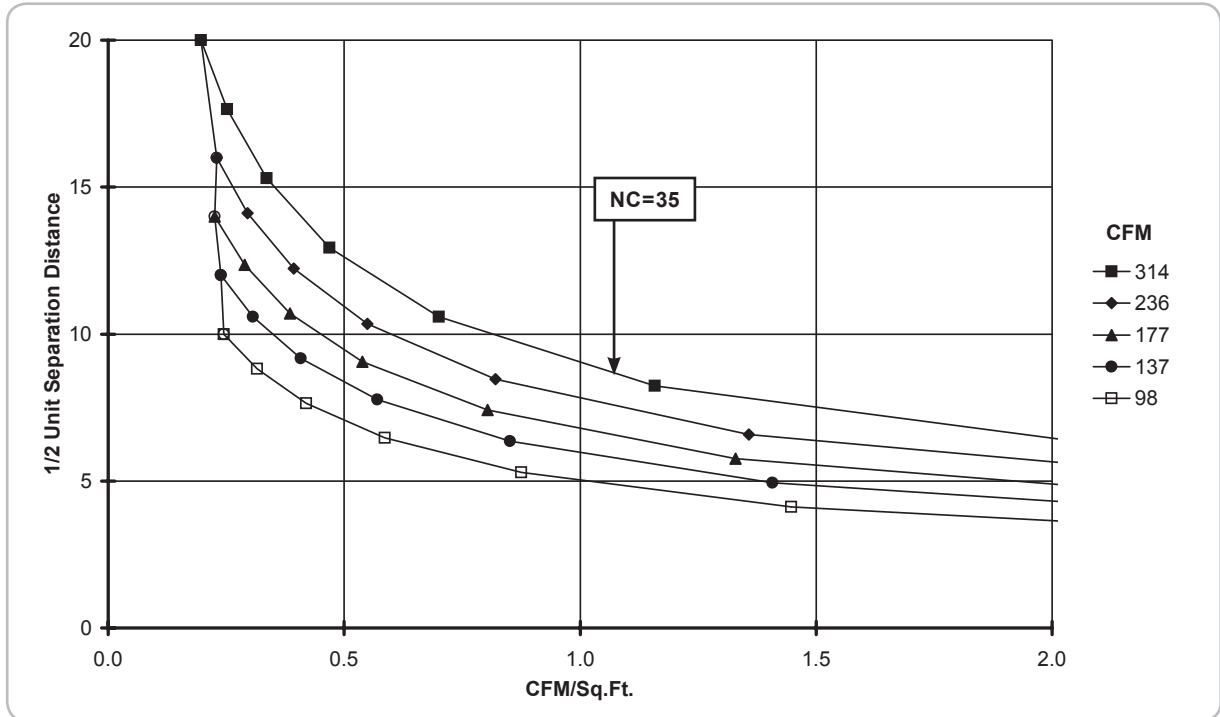

► Chart above is at a 20 BTUH/ft² load.
See the Engineering section of this catalog for instructions on how to read these charts and additional ADPI information.



KSD REFERENCE CHARTS: HORIZONTAL THROW

▼ DIFFUSER SPACING FOR 80% ADPI: KSD, 10" NECK (NO DAMPER)

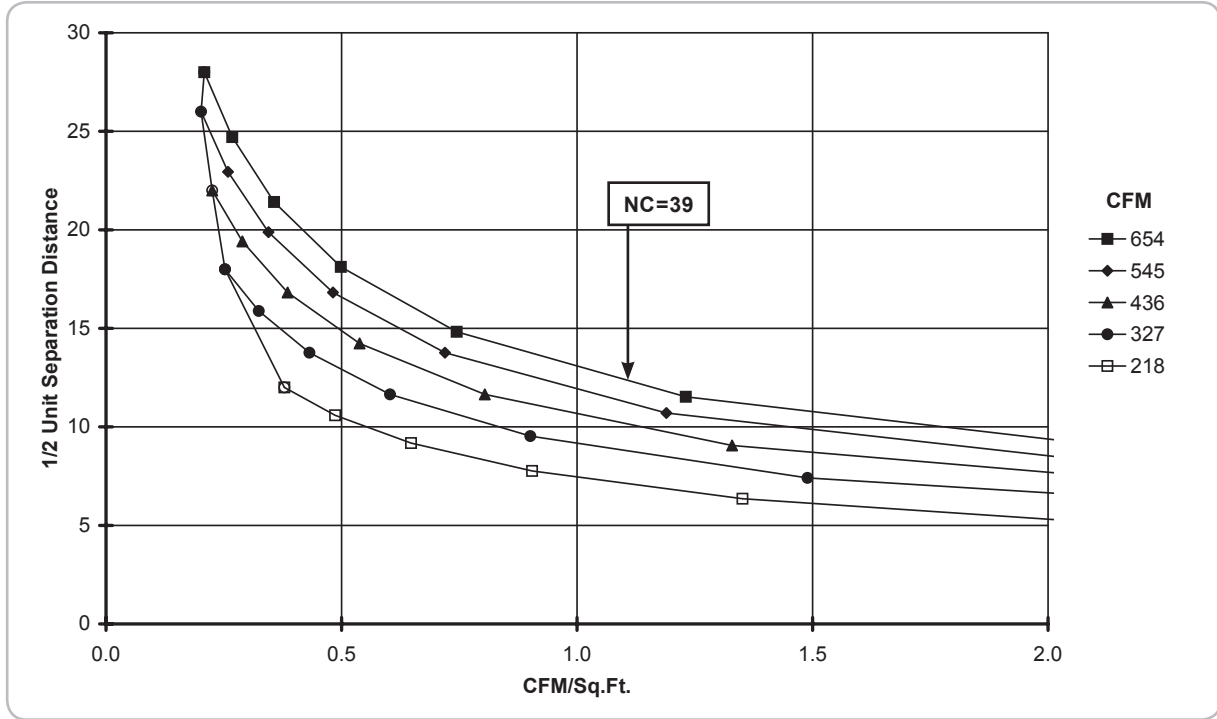

▼ DIFFUSER SPACING FOR 80% ADPI: KSD, 14" NECK (NO DAMPER)

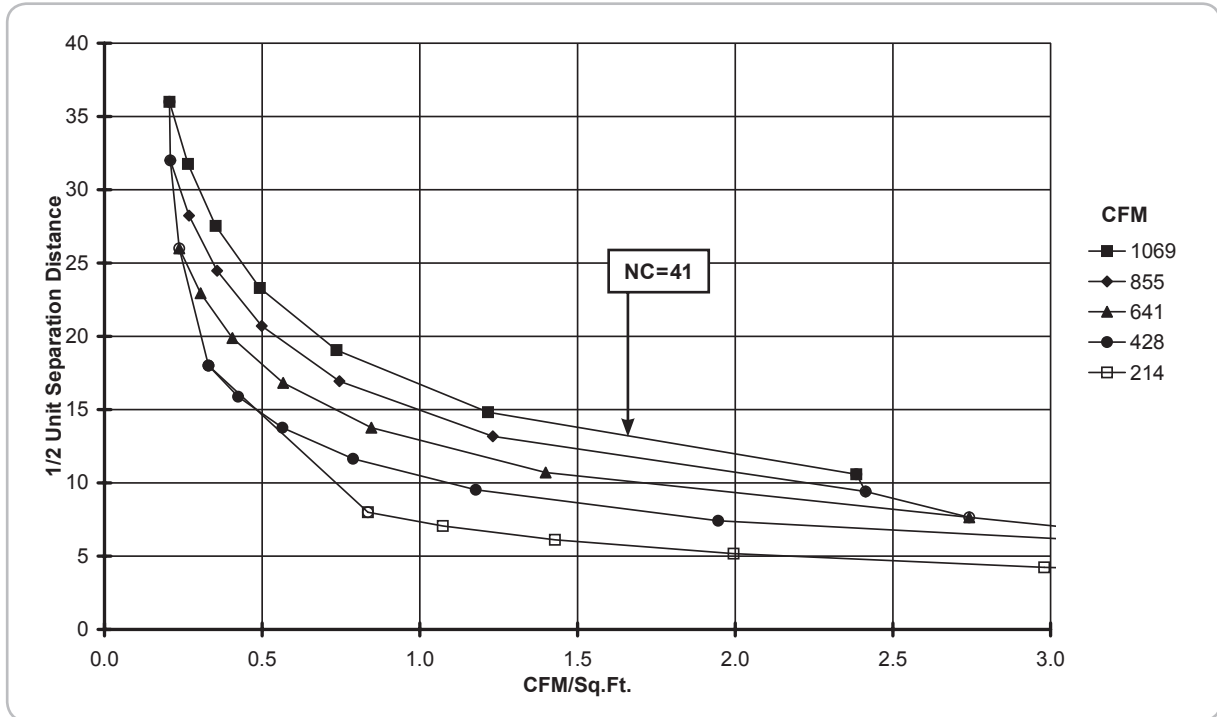

► Charts are at 20 BTUH/ft² loads.
See the Engineering section of this catalog for instructions on how to read these charts and additional ADPI information.

ARCHITECTURAL & PLAQUE DIFFUSERS

KSD

© KRUEGER 2006

KSD PERFORMANCE DATA: HORIZONTAL THROW
▼ IP/METRIC DATA: KSD (NO DAMPER)

	IP Data						NC	Metric Data					Octave Band, dB						
	Neck Vel	Air Flow	Ps	Pt	Throw	Neck Vel		Air Flow	Ps	Pt	Throw	2	3	4	5	6	7		
	FPM	CFM	"WG	"WG	ft	m/s		L/s	Pa	Pa	m								
6"	500	98	0.00	0.02	2 - 2 - 5	-	2.5	46	1	5	0.5 - 0.7 - 1.4	25	21	18	13	-	-		
	600	118	0.01	0.03	2 - 3 - 5	-	3.0	56	1	7	0.6 - 0.8 - 1.7	29	25	23	18	11	-		
	700	137	0.01	0.04	2 - 3 - 6	11	3.6	65	2	9	0.6 - 1.0 - 1.9	32	29	27	23	16	14		
	800	157	0.01	0.05	2 - 4 - 7	15	4.1	74	2	12	0.7 - 1.1 - 2.0	35	33	31	27	20	18		
	900	177	0.01	0.06	3 - 4 - 7	18	4.6	83	3	16	0.8 - 1.3 - 2.2	38	35	34	30	24	21		
	1000	196	0.02	0.08	3 - 5 - 8	21	5.1	93	4	19	0.9 - 1.4 - 2.3	40	38	36	33	28	24		
	1200	236	0.02	0.11	4 - 5 - 8	27	6.1	111	6	28	1.1 - 1.7 - 2.5	44	43	41	38	34	29		
	1400	275	0.03	0.15	4 - 6 - 9	31	7.1	130	8	38	1.3 - 1.9 - 2.7	47	46	45	43	39	34		
1600	314	0.04	0.20	5 - 7 - 10	35	8.1	148	10	50	1.5 - 2.0 - 2.9	50	50	49	46	43	38			
8"	500	175	0.02	0.03	2 - 3 - 6	-	2.5	82	4	8	0.6 - 0.9 - 1.9	31	27	24	19	13	11		
	600	209	0.02	0.04	2 - 4 - 7	13	3.0	99	5	11	0.7 - 1.1 - 2.2	34	31	28	24	19	16		
	700	244	0.03	0.06	3 - 4 - 8	17	3.6	115	7	15	0.9 - 1.3 - 2.6	38	35	33	29	24	21		
	800	279	0.04	0.08	3 - 5 - 9	21	4.1	132	10	20	1.0 - 1.5 - 2.7	40	38	36	33	28	24		
	900	314	0.05	0.10	4 - 5 - 10	25	4.6	148	12	25	1.1 - 1.7 - 2.9	43	41	39	36	32	28		
	1000	349	0.06	0.12	4 - 6 - 10	28	5.1	165	15	31	1.2 - 1.9 - 3.1	45	44	42	39	36	31		
	1100	384	0.07	0.15	4 - 7 - 11	31	5.6	181	18	37	1.4 - 2.0 - 3.2	47	46	45	42	39	33		
	1200	419	0.09	0.18	5 - 7 - 11	33	6.1	198	22	44	1.5 - 2.2 - 3.3	49	48	47	44	42	36		
1300	454	0.10	0.21	5 - 8 - 11	36	6.6	214	26	52	1.6 - 2.4 - 3.5	50	50	49	47	44	38			
10"	400	218	0.02	0.03	2 - 3 - 6	-	2.0	103	5	7	0.5 - 0.9 - 1.9	30	26	22	18	12	-		
	500	273	0.03	0.05	3 - 4 - 8	13	2.5	129	7	11	0.8 - 1.2 - 2.3	35	31	28	24	19	16		
	600	327	0.04	0.07	3 - 5 - 9	18	3.0	154	11	16	0.9 - 1.4 - 2.8	38	36	33	29	25	21		
	700	382	0.06	0.09	4 - 5 - 11	23	3.6	180	15	22	1.1 - 1.6 - 3.2	42	39	37	34	30	26		
	800	436	0.08	0.12	4 - 6 - 11	27	4.1	206	19	29	1.2 - 1.9 - 3.4	44	43	40	38	35	29		
	900	491	0.10	0.15	5 - 7 - 12	30	4.6	232	24	37	1.4 - 2.1 - 3.6	47	46	43	41	38	33		
	1000	545	0.12	0.18	5 - 8 - 13	33	5.1	257	30	45	1.5 - 2.3 - 3.8	49	48	46	44	42	36		
	1100	600	0.14	0.22	6 - 8 - 13	36	5.6	283	36	55	1.7 - 2.6 - 4.0	51	51	49	47	45	38		
1200	654	0.17	0.26	6 - 9 - 14	39	6.1	309	43	65	1.9 - 2.8 - 4.2	53	53	51	49	48	41			
12"	300	236	0.02	0.02	1 - 3 - 5	-	1.5	111	4	6	0.3 - 0.8 - 1.7	27	22	18	13	-	-		
	400	314	0.03	0.04	2 - 4 - 7	-	2.0	148	8	10	0.6 - 1.1 - 2.2	33	29	25	21	17	14		
	500	393	0.05	0.06	3 - 5 - 9	17	2.5	185	12	16	0.9 - 1.4 - 2.8	38	35	31	28	24	20		
	600	471	0.07	0.09	4 - 5 - 11	22	3.0	222	17	23	1.1 - 1.7 - 3.3	42	39	36	33	30	25		
	700	550	0.09	0.12	4 - 6 - 13	27	3.6	259	23	31	1.3 - 1.9 - 3.8	45	43	40	38	35	30		
	800	628	0.12	0.16	5 - 7 - 13	31	4.1	297	30	40	1.5 - 2.2 - 4.1	48	46	44	41	40	34		
	900	707	0.15	0.20	5 - 8 - 14	34	4.6	334	38	51	1.7 - 2.5 - 4.3	50	49	47	45	44	37		
	1000	785	0.19	0.25	6 - 9 - 15	37	5.1	371	47	63	1.9 - 2.8 - 4.6	52	52	50	48	47	40		
1100	864	0.23	0.31	7 - 10 - 16	40	5.6	408	57	76	2.0 - 3.1 - 4.8	54	54	52	51	50	43			
14"	200	214	0.01	0.01	1 - 1 - 4	-	1.0	101	3	3	0.2 - 0.4 - 1.3	22	15	-	-	-	-		
	300	321	0.02	0.03	1 - 3 - 6	-	1.5	151	6	8	0.4 - 0.9 - 1.9	30	25	21	17	12	-		
	400	428	0.04	0.05	2 - 4 - 9	14	2.0	202	11	13	0.7 - 1.3 - 2.6	36	32	28	25	21	18		
	500	535	0.07	0.08	4 - 5 - 11	20	2.5	252	17	21	1.1 - 1.6 - 3.2	41	38	34	31	29	24		
	600	641	0.10	0.12	4 - 6 - 13	26	3.0	303	25	30	1.3 - 1.9 - 3.9	45	42	39	37	35	29		
	700	748	0.13	0.17	5 - 7 - 15	30	3.6	353	33	41	1.5 - 2.3 - 4.5	48	46	43	41	40	33		
	800	855	0.18	0.22	6 - 9 - 16	34	4.1	404	44	54	1.7 - 2.6 - 4.8	51	49	47	45	44	37		
	900	962	0.22	0.27	6 - 10 - 17	38	4.6	454	55	68	1.9 - 2.9 - 5.1	53	52	50	48	48	40		
1000	1069	0.27	0.34	7 - 11 - 18	41	5.1	505	68	84	2.2 - 3.2 - 5.3	55	55	53	51	51	43			

► Throw values are given for isothermal conditions and terminal velocities of 150, 100, and 50 FPM (0.75, 0.50, and 0.25 m/s). NC values are based on octave band 2 - 7 sound power levels minus a room absorption of 10dB, re 10⁻¹² watts. Dash (-) in space denotes a NC or dB value of less than 10. Data was obtained from tests conducted in accordance with ANSI/ASHRAE Standard 70. See K-Select program for performance data not shown, including octave band data.



KSD SUGGESTED SPECIFICATION & CONFIGURATION

KSD

The architectural square panel ceiling diffusers of the sizes and mounting types shown on the plans or outlet schedule shall be the Krueger model KSD constructed of steel backpan wrapped with a heavy gage aluminum face. The KSD shall have fixed deflectors to maintain maximum discharge effectiveness and project air in a 360° horizontal plane in the room. Optional duct or neck mounted round damper shall be constructed of heavy gage steel. Damper shall be operable from the face of the diffuser.

FINISH

The paint finish shall be #44 White and be a P-Series Powder Coating finish, baked at 400°F for 7 minutes. The paint thickness shall be 1.8 – 2.2 mils, pencil hardness per ASTM D3363 of H – 2H, crosshatch adhesion per ASTM D3359 of 4B, impact per ASTM D2794 of direct and reverse impact range of 40 to 160 in/lb depending on formulation, salt spray per ASTM B117 of 1000 hours, humidity per ASTM D2247 of 1000 hours and water soak per ASTM D8702 of 500 hours.

PERFORMANCE

The manufacturer shall provide published performance data for the diffuser. The diffuser shall be tested in accordance to the data standards at the time of product introduction or ANSI/ASHRAE Standard 70.

1. DIFFUSER SERIES: (XXX)

KSD - Swirl Diffuser, Steel Construction

2. NECK: (XX)

6", 8", 10", 12", 14"

3. FRAME: (XXX)

F23 - Lay-in T-bar

4. PANEL: (XX)x(XX)

24"x24"

5. FINISH: (XX)

01 - Mill

36 - Black Gloss

44 - British White

50 - Bright White

70 - Silver Metallic

99 - Custom Color