

JOB NAME _____
 ARCHITECT _____
 ENGINEER _____
 CONTRACTOR _____
 LOCATION _____

SUBMITTAL SHEET
 Form Number TUS0330.5 Effective Date 8/20
 Replaces FORM TUS0330.4

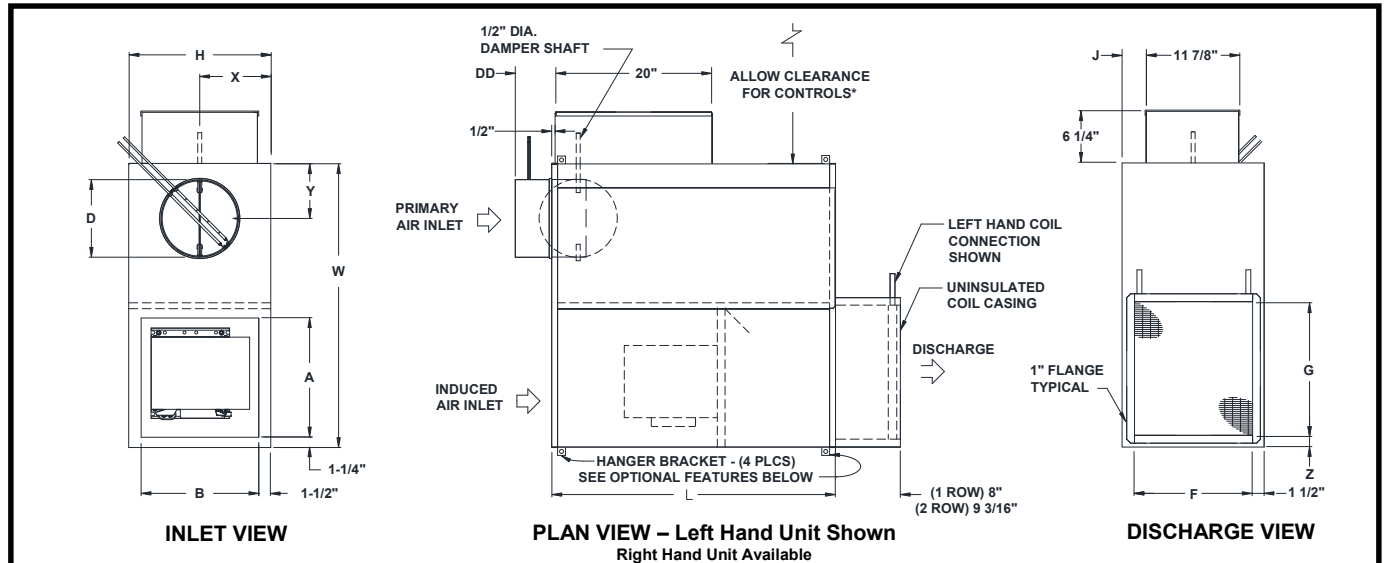

KQFP w/ ELECTRONIC CONTROLS & HOT WATER HEAT ON UNIT DISCHARGE
VARIABLE VOLUME FAN TERMINAL UNIT, SIZES 2-7



STANDARD FEATURES:

- 20 Ga. galvanized steel construction
- Control enclosure for electronic components
- 1/2" thick dual density fiberglass insulation meeting **NFPA 90A** and **UL 181** safety requirements
- 120V 208V/240V 277V multi-voltage, single speed, single phase, permanently lubricated PSC motors
- Field adjustable fan speed control
- Integral induced air attenuator
- Motor/blower isolation
- Back draft damper assembly
- Four quadrant averaging cross flow sensor inlet sizes 6–10 (DD = 4 7/8") sizes 12–16 (DD = 6 7/8").
- Removable bottom panel allows easy access to motor-blower assembly and primary air damper
- Discharge requires a flanged duct connection by others.
- Factory supplied 24 volt control transformer
- **ETL** listed – Adherence to **UL1995** and **CSA C22.2 No.236.95**.
- **AHRI** certified sound ratings

NOTE: Dimensions are given in inches

*Check NEC for unit clearance requirements

OPTIONAL FEATURES:

- ECM Motor (Available on Unit Size 4 & 7)
 - Manual Control 0-10Vdc Remote Control
 - 2-10Vdc Remote Control
 - 120V 208V/240V 277V
- Liners:
 - 1" Dual density fiberglass insulation
 - 1/2" Cellular insulation
 - 1" Cellular insulation
 - 13/16" Steriliner Duct Board Insulation
 - 1/2" Foil encapsulated fiberglass insulation
 - 1" Foil encapsulated fiberglass insulation
 - Solid Metal Liner w/ 1/2" Dual Density Fiberglass
 - Perforated Metal Liner w/ 1/2" Dual Density Fiberglass
- Linear average sensor / inlet size 6–10 (DD = 4 7/8"), sizes 12–16 (DD = 6 7/8")
- Motor disconnect Cam lock bottom access
- Motor fusing Coil vent and drain
- Induced air filter (Unit Size 2-4: 17"x17"x1", Unit Size 5-7: 22"x19"x1")
- Dust tight control enclosure
- Hanger Brackets (not available with Double wall or Perf Double wall)

UNIT SIZE	INLET SIZE	PSC HP	ECM HP	L	W	H	INDUCED AIR		D	DISCHARGE		J	X	Y	Z
							A	B		F	G				
2	06	1/4	-	36 1/8	36 1/8	18 1/16	15 1/8	15	5 7/8	15 1/8	17	3 1/8	9	6	2
2	08	1/4	-	36 1/8	36 1/8	18 1/16	15 1/8	15	7 7/8	15 1/8	17	3 1/8	9	6	2
3	08	1/4	-	36 1/8	36 1/8	18 1/16	15 1/8	15	7 7/8	15 1/8	17	3 1/8	9	6	2
4	06	1/4	1/2	36 1/8	36 1/8	18 1/16	15 1/8	15	5 7/8	15 1/8	17	3 1/8	9	6	2
4	08	1/4	1/2	36 1/8	36 1/8	18 1/16	15 1/8	15	7 7/8	15 1/8	17	3 1/8	9	6	2
4	10	1/4	1/2	36 1/8	36 1/8	18 1/16	15 1/8	15	9 7/8	15 1/8	17	3 1/8	9	7	2
4	12	1/4	1/2	36 1/8	36 1/8	18 1/16	15 1/8	15	11 7/8	15 1/8	17	3 1/8	9	8	2
5	12	1/2	-	42 1/8	46 1/8	20 1/16	20 1/8	17	11 7/8	17 5/8	25	4 1/8	10	8	1
5	14	1/2	-	42 1/8	46 1/8	20 1/16	20 1/8	17	13 7/8	17 5/8	25	4 1/8	10	10	1
6	14	1/2	-	42 1/8	46 1/8	20 1/16	20 1/8	17	13 7/8	17 5/8	25	4 1/8	10	10	1
6	16	1/2	-	42 1/8	46 1/8	20 1/16	20 1/8	17	15 7/8	17 5/8	25	4 1/8	10	10 1/4	1
7	12	3/4	1	42 1/8	46 1/8	20 1/16	20 1/8	17	11 7/8	17 5/8	25	4 1/8	10	8	1
7	14	3/4	1	42 1/8	46 1/8	20 1/16	20 1/8	17	13 7/8	17 5/8	25	4 1/8	10	10	1
7	16	3/4	1	42 1/8	46 1/8	20 1/16	20 1/8	17	15 7/8	17 5/8	25	4 1/8	10	10 1/4	1