

JOB NAME _____
 ARCHITECT _____
 ENGINEER _____
 CONTRACTOR _____
 LOCATION _____

SUBMITTAL SHEET
 Form Number GS0322.5 Effective Date 12/17
 Replaces FORM GS0322.4



AFS580H, V, HZ, or VZ SERIES
Single Row Fixed Extruded Blades

Architectural Return Grille
 Page 1 of 2

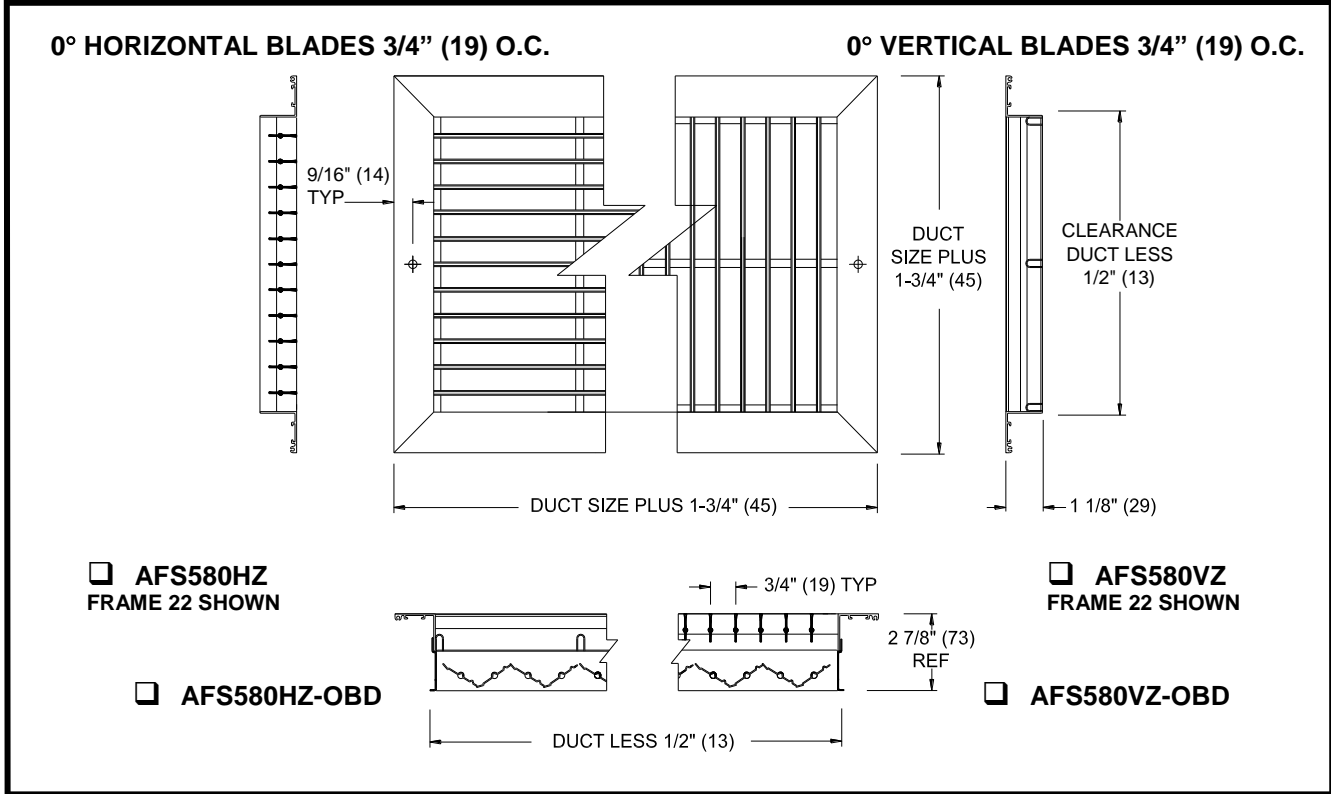
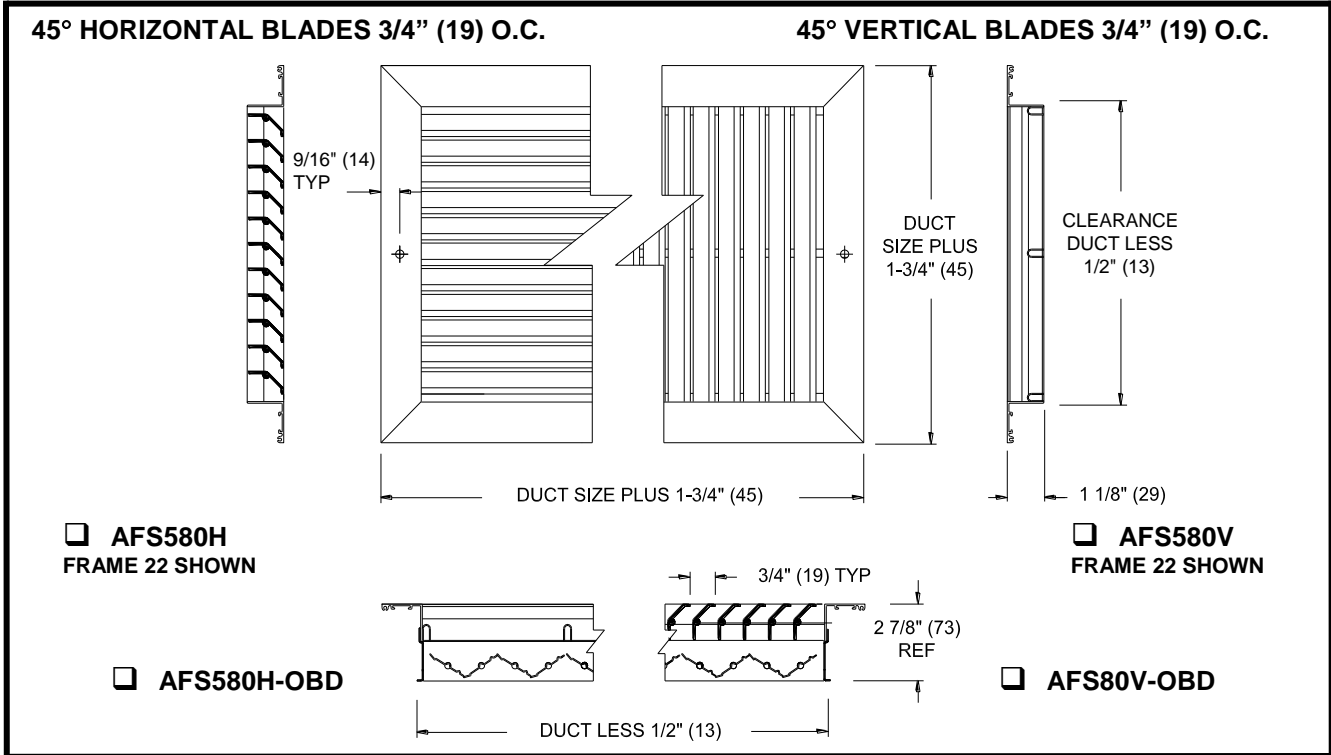

JOB NAME _____
 ARCHITECT _____
 ENGINEER _____
 CONTRACTOR _____
 LOCATION _____

SUBMITTAL SHEET
 Form Number GS0322.5 Effective Date 12/17
 Replaces FORM GS0322.4



AFS580H, V, HZ, or VZ SERIES
Options and Accessories

FRAME 22
SURFACE MOUNT

FRAME 23
LAY-IN T-BAR

FRAME 98
NARROW TEE

FTB
CHANNEL FRAME

BASIC FASTENING OPTIONS

NO SCREW HOLES

STANDARD SCREW HOLES

CONCEALED FASTENING
NOT AVAILABLE WITH 'H' AND 'V' PATTERNS OR OBD/5OBD DAMPERS

58PF
PLASTER FRAME

FILTER FRAME OPTION

KNURLED / HINGE TOP

KNURLED / HINGE BOTTOM

KNURLED / HINGE RIGHT

KNURLED / HINGE LEFT

KNURLED / NO HINGE

1/4 TURN / HINGE TOP

1/4 TURN / HINGE BOTTOM

1/4 TURN / HINGE RIGHT

1/4 TURN / HINGE LEFT

1/4 TURN / NO HINGE

DIMENSIONS ARE SHOWN AS INCHES (MM)

* MAXIMUM DUCT SIZE FOR F23 AND F98 EQUALS PANEL SIZE MINUS 5" (127)

NOTES:
 AFS580H / V / HZ / VZ UNITS ARE ALUMINUM CONSTRUCTION.
 SUPPORT MULLIONS 12" (305) MAX SPACING.

OPTIONAL ACCESSORIES :

OBD (22 GA) STEEL OPPOSED BLADE DAMPER

5OBD ALUMINUM OPPOSED BLADE DAMPER

58PF PLASTER FRAME

1" FILTER FRAME

2" FILTER FRAME

IS INSECT SCREEN

DS DEBRIS SCREEN