

**DMD Dimensional Information**

**DMD, FACE VIEW, SIDE VIEW, & CROSS SECTIONS**

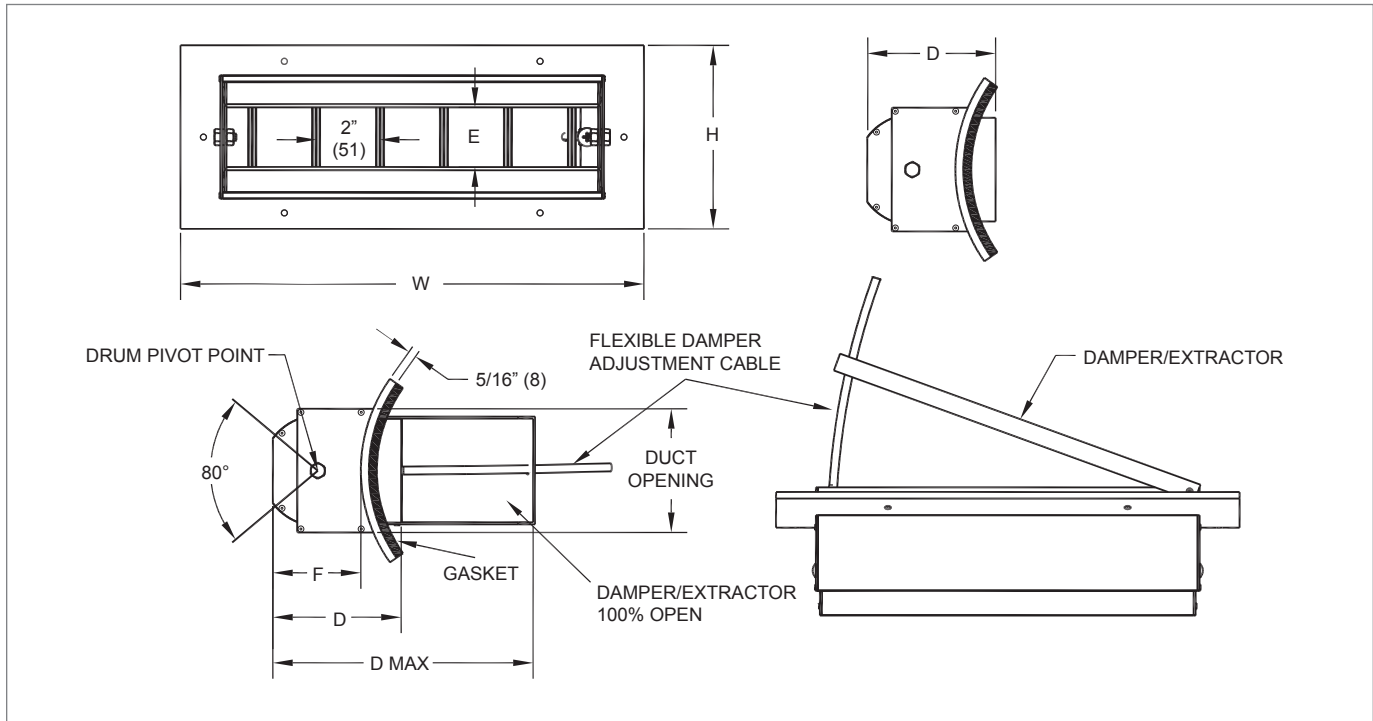

DUCT MOUNTED GRILLES & LOUVERS

**DMD, AVAILABLE SIZES**

Nominal Duct Size	H	W	E	F	D	D MAX	Minimum Round Duct	Blade Qty	Screw Holes
12 x 4	6 1/2" (165)	14 3/8" (365)	2" (51)	3 1/8" (79)	4" (102)	17 1/4" (438)	8" (203)	6	6
18 x 4		20 3/8" (518)						9	8
24 x 4		26 3/8" (670)						12	10
30 x 4		32 3/8" (822)						15	10
36 x 4		38 3/8" (975)						18	12
42 x 4		44 3/8" (1127)						21	12
48 x 4		50 3/8" (1280)						24	14
60 x 4		62 3/8" (1584)						30	16
12 x 6	8 1/2" (216)	14 3/8" (365)	3 1/2" (89)	3 7/8" (98)	4 3/4" (121)	18" (457)	10" (254)	6	6
18 x 6		20 3/8" (518)						9	8
24 x 6		26 3/8" (670)						12	10
30 x 6		32 3/8" (822)						15	10
36 x 6		38 3/8" (975)						18	12
42 x 6		44 3/8" (1127)						21	12
48 x 6		50 3/8" (1280)						24	14
60 x 6		62 3/8" (1584)						30	16
12 x 8	10 1/2" (267)	14 3/8" (365)	5" (127)	4 1/2" (114)	5 1/2" (140)	18 3/4" (476)	12" (305)	6	6
18 x 8		20 3/8" (518)						9	8
24 x 8		26 3/8" (670)						12	10
30 x 8		32 3/8" (822)						15	10
36 x 8		38 3/8" (975)						18	12
42 x 8		44 3/8" (1127)						21	12
48 x 8		50 3/8" (1280)						24	14
60 x 8		62 3/8" (1584)						30	16
12 x 10	12 1/2" (318)	14 3/8" (365)	6 5/8" (168)	5 1/4" (133)	6 1/4" (159)	19 1/2" (495)	14" (356)	6	6
18 x 10		20 3/8" (518)						9	8
24 x 10		26 3/8" (670)						12	10
30 x 10		32 3/8" (822)						15	10
36 x 10		38 3/8" (975)						18	12
42 x 10		44 3/8" (1127)						21	12
48 x 10		50 3/8" (1280)						24	14
60 x 10		62 3/8" (1584)						30	16

NOTES: Dimensions in parentheses are mm.