

JOB NAME \_\_\_\_\_  
 ARCHITECT \_\_\_\_\_  
 ENGINEER \_\_\_\_\_  
 CONTRACTOR \_\_\_\_\_  
 LOCATION \_\_\_\_\_

**SUBMITTAL SHEET**  
 Form Number GS0115 Effective Date 1/05  
 NEW

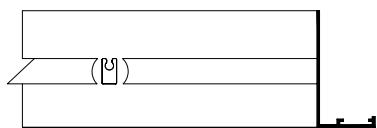

**5810 – 5815 CORE ADJUSTMENT GUIDE**

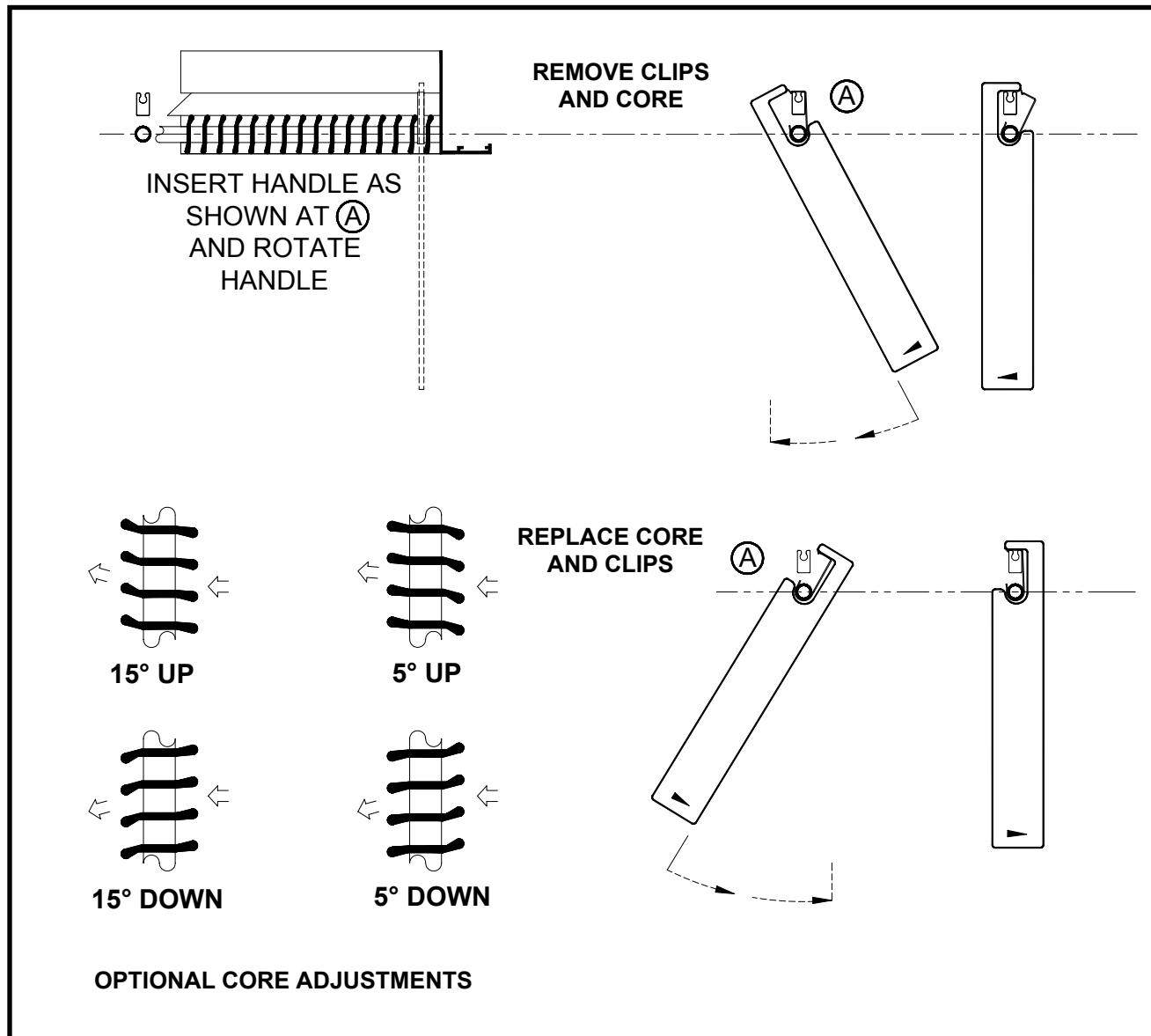

5810 / 5815 FRAME ASSEMBLY

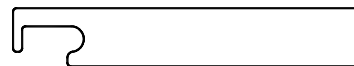

SPRING CLIP HANDLE  
 P/N 717235



5810 / 5815 CORE



SPRING CLIP  
 P/N 42210057