

JOB NAME _____
 ARCHITECT _____
 ENGINEER _____
 CONTRACTOR _____
 LOCATION _____

SUBMITTAL SHEET
 Form Number GS0054 Effective Date 12/04
 Replaces Form GS0014.1



S480HZ / S480VZ SERIES

HEAVY DUTY 0° FIXED BLADE, SIDEWALL RETURN GRILLES

- S480VZ w/ OBD
- S480HZ w/ OBD

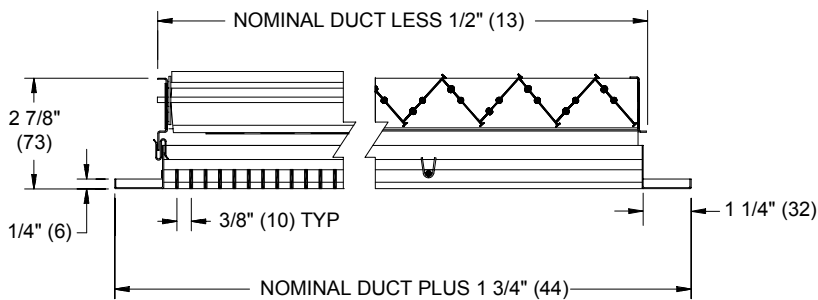

CENTER CROSS SECTION w/ OBD

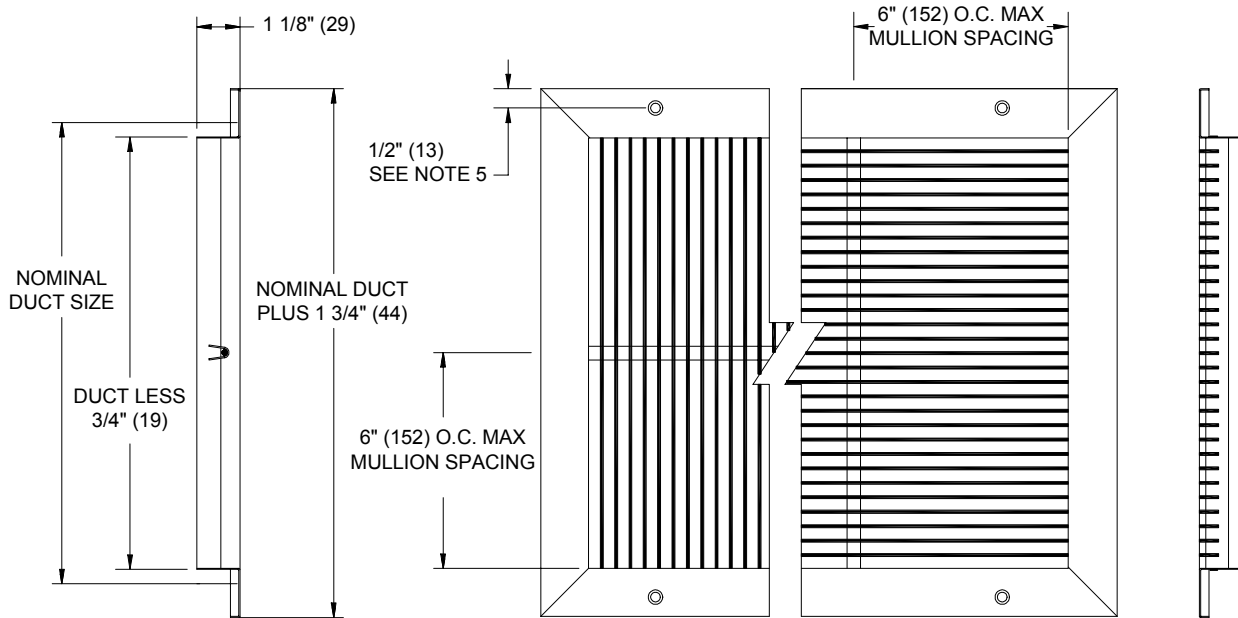

S480VZ
CROSS SECTION

FACE VIEWS

S480HZ
CROSS SECTION

NOTES :

1. HZ OR VZ DESIGNATES HORIZONTAL OR VERTICAL HEAVY DUTY BLADES FIXED ON 3/8" (10) CENTERS BY ROD AND MULLION SUPPORTS.
2. CONSTRUCTION IS STEEL : 16GA FRAME, 14 GA BLADES.
3. OPTIONAL OBD SHIPS ATTACHED TO UNIT.
4. MAXIMUM SIZE OF A SINGLE CORE UNIT IS 48" x 48".
5. SCREW HOLE QUANTITY AND LOCATION WILL VARY WITH UNIT SIZE.

DIMENSIONS ARE GIVEN AS INCHES (MM)