

JOB NAME \_\_\_\_\_  
 ARCHITECT \_\_\_\_\_  
 ENGINEER \_\_\_\_\_  
 CONTRACTOR \_\_\_\_\_  
 LOCATION \_\_\_\_\_

**SUBMITTAL SHEET**  
 Form Number GS0005.3 Effective Date 5/13  
 Replaces Form GS0005.2

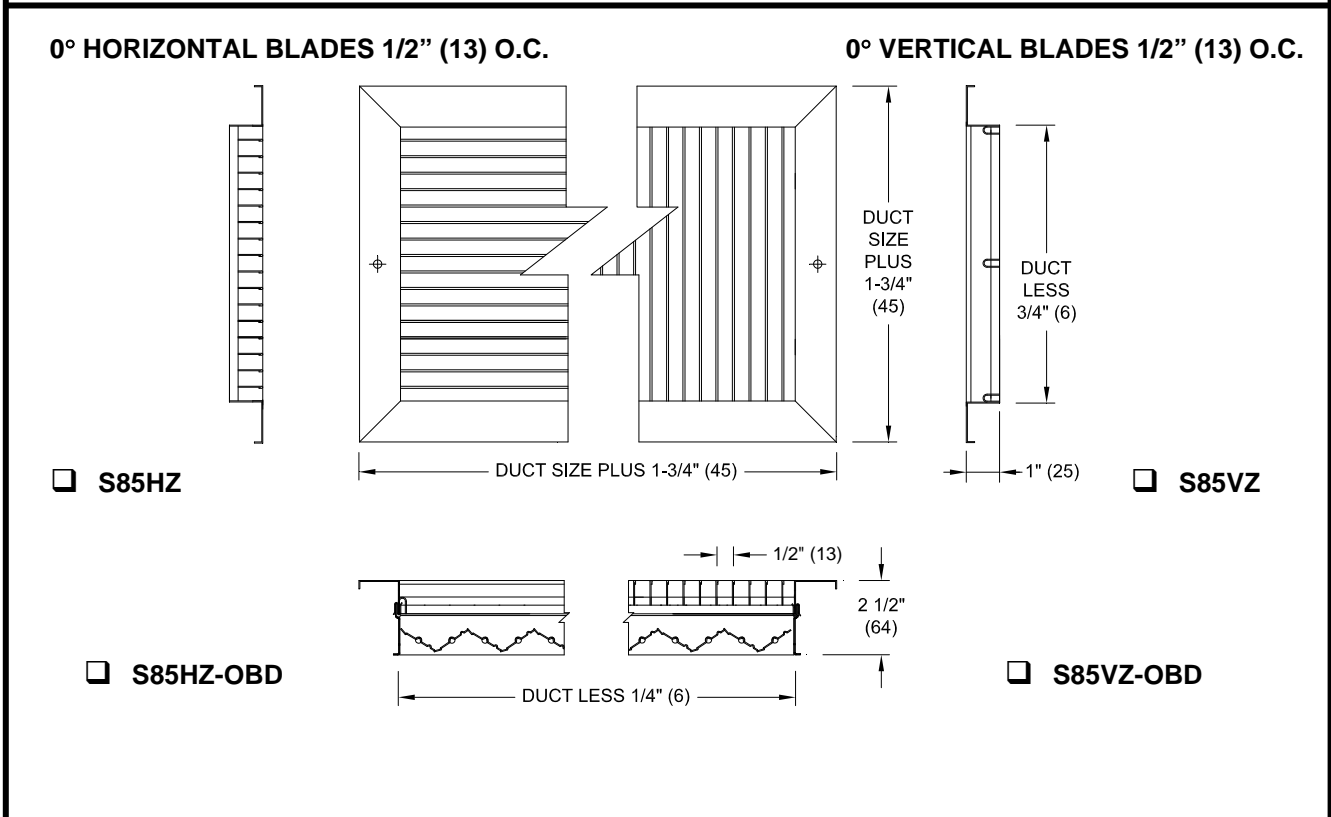

**S85H, V or HZ, VZ SERIES**  
**1/2" Spaced Fixed Blade Steel Return Grille**

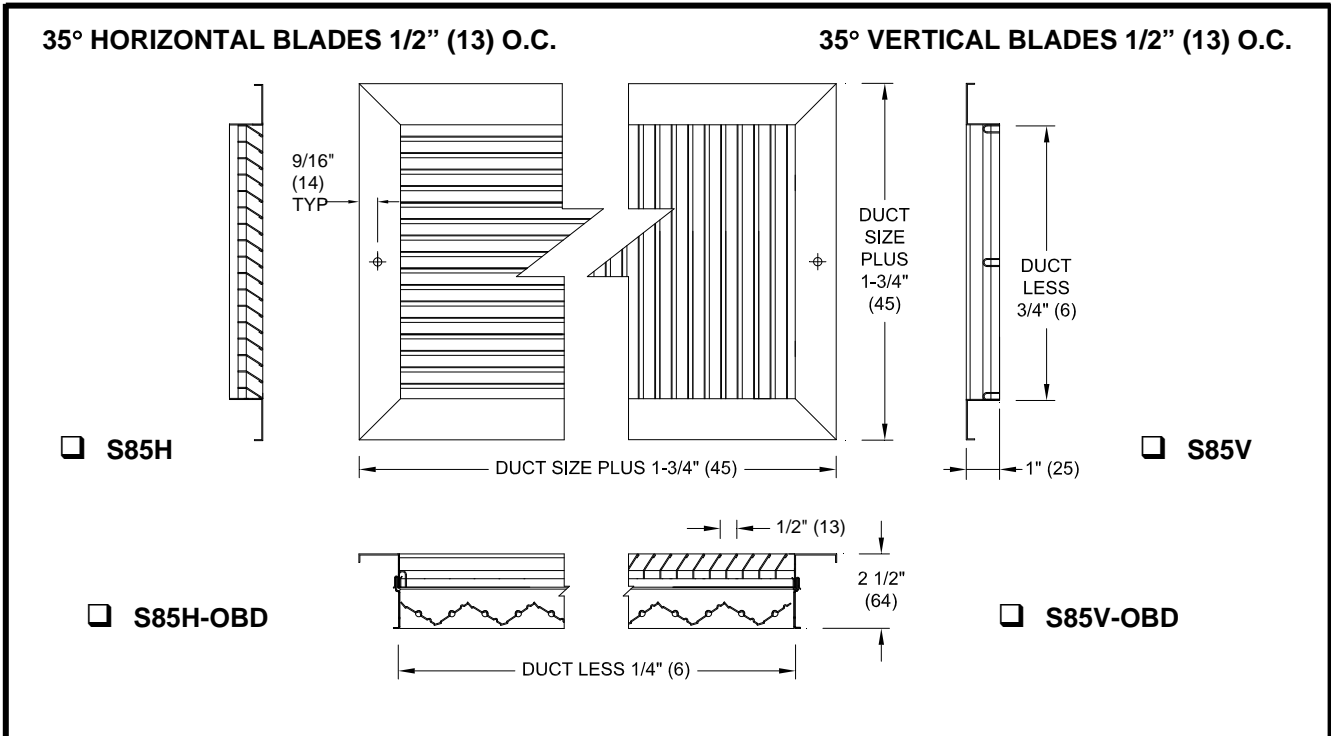

JOB NAME \_\_\_\_\_  
 ARCHITECT \_\_\_\_\_  
 ENGINEER \_\_\_\_\_  
 CONTRACTOR \_\_\_\_\_  
 LOCATION \_\_\_\_\_

**SUBMITTAL SHEET**  
 Form Number GS0005.3 Effective Date 5/13  
 Replaces Form GS0005.2



**S85H, V or HZ, VZ SERIES**  
**Options and Accessories**

**BASIC FRAME STYLES**

**Frame 22**  
SURFACE MOUNT

**Frame 23**  
LAY-IN T-BAR

**Frame 98**  
NARROW TEE

**BASIC FASTENING METHODS**

**NO SCREW HOLES**

**STANDARD SCREW HOLES**

**CONCEALED FASTENING**  
 Shown to the right  
 OBD/5OBD not available with concealed mounting

**FILTER FRAME OPTION**

MAXIMUM DUCT SIZE EQUALS  
 PANEL SIZE LESS 5" (127)

1" FILTER FRAME  
2 5/8" (66)

2" FILTER FRAME  
3 5/8" (92)

Frame 23 Shown

NOMINAL DUCT

PANEL LESS 1/4" (6)

5/16" (8)

PANEL LESS 5/8" (16)

Frame 98 Shown

DUCT SIZE

1" FILTER FRAME  
2 3/8" (62)

2" FILTER FRAME  
3 5/8" (92)

DUCT PLUS  
3 3/4" (96)

Frame 22 Shown

**KNURLED / HINGE TOP**

**KNURLED / HINGE BOTTOM**

**KNURLED / HINGE RIGHT**

**KNURLED / HINGE LEFT**

**KNURLED / NO HINGE**

**1/4 TURN / HINGE TOP**

**1/4 TURN / HINGE BOTTOM**

**1/4 TURN / HINGE RIGHT**

**1/4 TURN / HINGE LEFT**

**1/4 TURN / NO HINGE**

**DIMENSIONS ARE SHOWN  
 AS INCHES (MM)**

\* MAXIMUM DUCT SIZE FOR F23 AND F98 EQUALS PANEL SIZE MINUS 5" (127)

**NOTES :**  
 S85H / V / HZ / VZ ARE ALL STEEL CONSTRUCTION. SUPPORT MULLIONS 8" (203) O.C.  
 DIMENSIONS ARE SHOWN AS INCHES (MM)

**OPTIONAL ACCESSORIES :**

**OBD (22 GA) STEEL OPPOSED BLADE DAMPER**

**POBD (22 GA) STEEL OPPOSED BLADE DAMPER PAINTED FINISH**

**5OBD ALUMINUM OPPOSED BLADE DAMPER**

**PLASTER FRAME**

**1" FILTER FRAME (NOT AVAILABLE WITH OBD)**

**2" FILTER FRAME (NOT AVAILABLE WITH OBD)**