

JOB NAME _____
 ARCHITECT _____
 ENGINEER _____
 CONTRACTOR _____
 LOCATION _____

SUBMITTAL SHEET
 Form Number GS0210.5 Effective Date 5/13
 Replaces Form GS0210.4



S585H, V or HZ, VZ SERIES

1/2" Spaced Fixed Blade Aluminum Return Grille

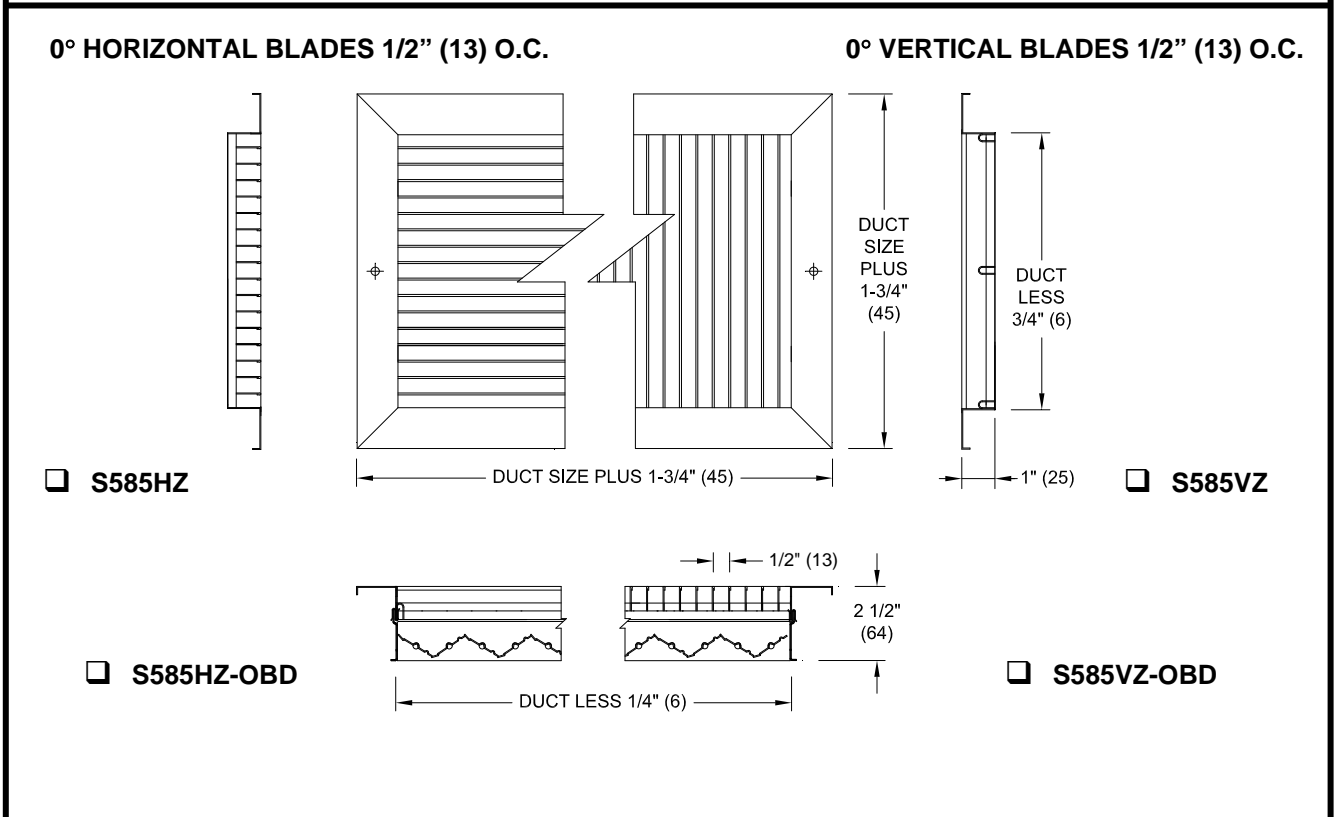
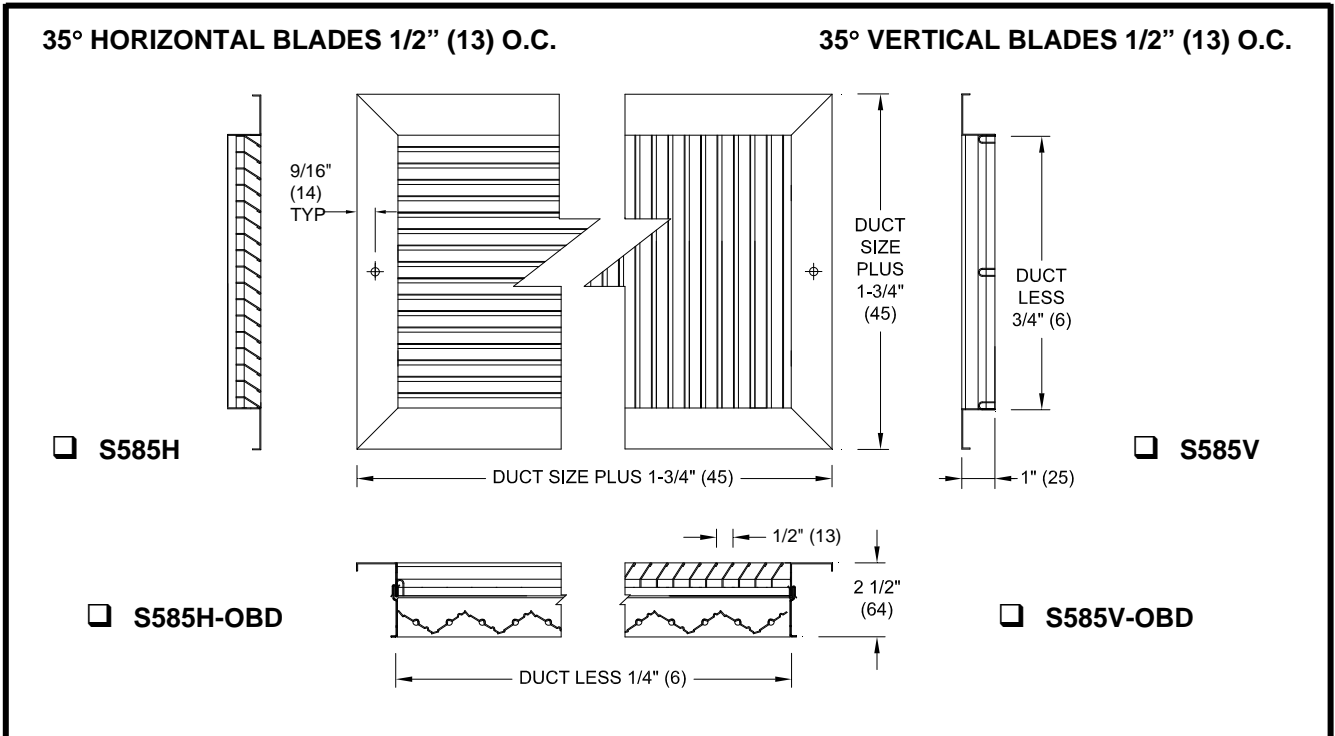

JOB NAME _____
 ARCHITECT _____
 ENGINEER _____
 CONTRACTOR _____
 LOCATION _____



S585H, V or HZ, VZ SERIES
Options and Accessories

BASIC FRAME STYLES

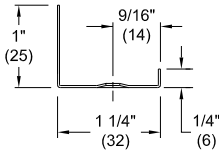

Frame 22
SURFACE MOUNT

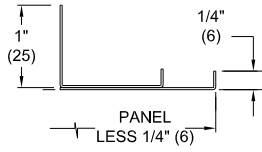

Frame 23
LAY-IN T-BAR

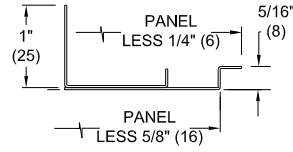

Frame 98
NARROW TEE

BASIC FASTENING METHODS

- NO SCREW HOLES**
- STANDARD SCREW HOLES**
- CONCEALED FASTENING**
 Shown to the right
 OBD/5OBD not available with concealed mounting

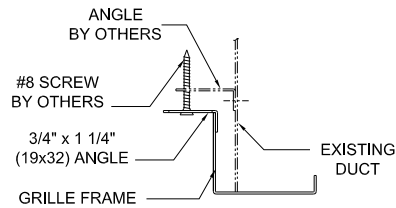

FILTER FRAME OPTION

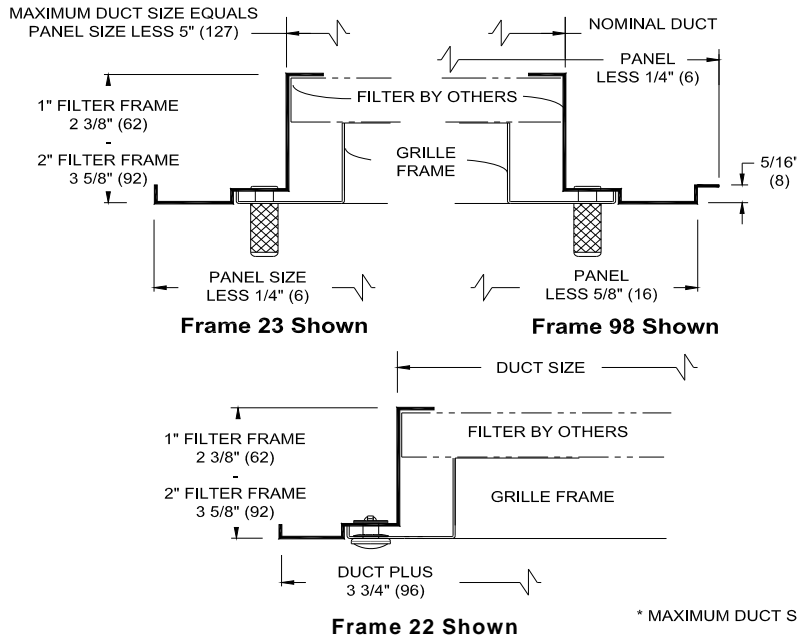

- KNURLED / HINGE TOP**
- KNURLED / HINGE BOTTOM**
- KNURLED / HINGE RIGHT**
- KNURLED / HINGE LEFT**
- KNURLED / NO HINGE**

- 1/4 TURN / HINGE TOP**
- 1/4 TURN / HINGE BOTTOM**
- 1/4 TURN / HINGE RIGHT**
- 1/4 TURN / HINGE LEFT**
- 1/4 TURN / NO HINGE**

DIMENSIONS ARE SHOWN AS INCHES (MM)

NOTES :

S585H / V / HZ / VZ ARE ALL ALUMINUM CONSTRUCTION. SUPPORT MULLIONS 8" (203) O.C.

DIMENSIONS ARE SHOWN AS INCHES (MM)

OPTIONAL ACCESSORIES :

- OBD (22 GA) STEEL OPPOSED BLADE DAMPER**
- POBD (22 GA) STEEL OPPOSED BLADE DAMPER PAINTED FINISH**
- 5OBD ALUMINUM OPPOSED BLADE DAMPER**
- PLASTER FRAME**
- 1" FILTER FRAME (NOT AVAILABLE WITH OBD)**
- 2" FILTER FRAME (NOT AVAILABLE WITH OBD)**