

JOB NAME \_\_\_\_\_  
 ARCHITECT \_\_\_\_\_  
 ENGINEER \_\_\_\_\_  
 CONTRACTOR \_\_\_\_\_  
 LOCATION \_\_\_\_\_

**SUBMITTAL SHEET**  
 Form Number GS0217 Effective Date 12/04  
 NEW



**AF880 SUPPLY GRILLE**  
**DOUBLE DEFLECTION ADJUSTABLE AIRFOIL BLADE**

- AF880H w/ OBD
- AF880V w/ OBD

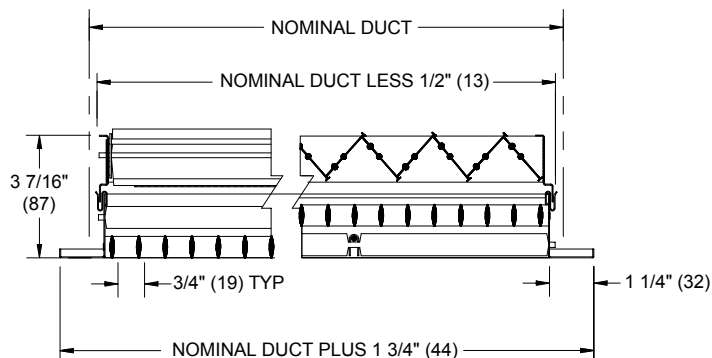

**CENTER CROSS SECTION w/ OBD**

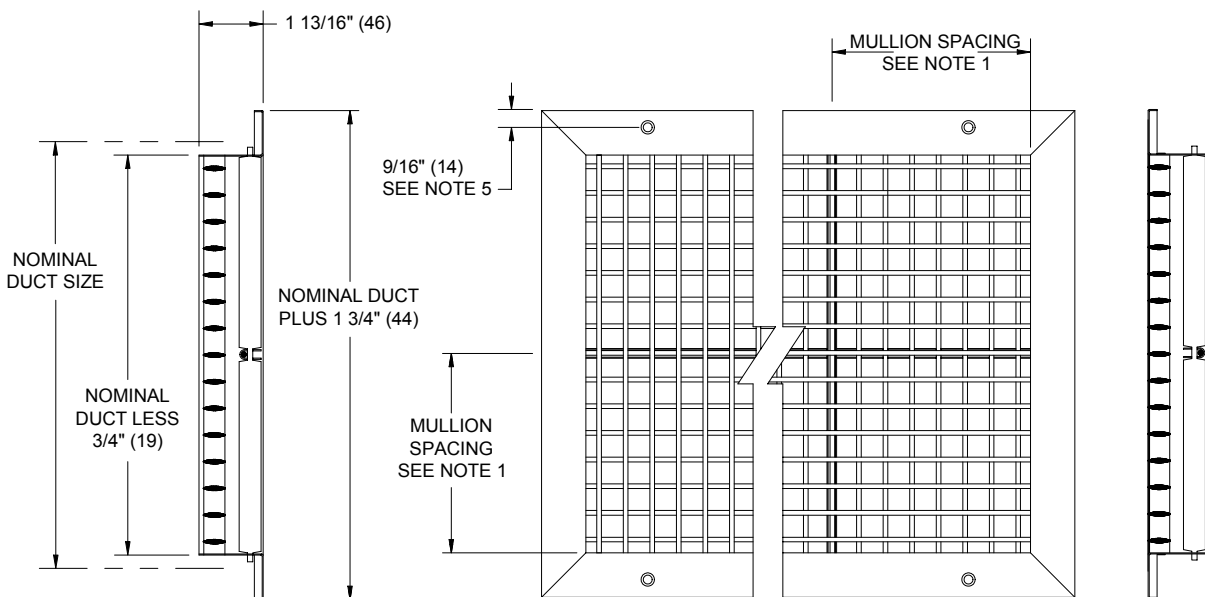

**AF880V**  
**CROSS SECTION**

**FACE VIEWS**

**AF880H**  
**CROSS SECTION**

**NOTES :**

1. H OR V DESIGNATES HORIZONTAL OR VERTICAL FRONT BLADES. ALL BLADES ARE ADJUSTABLE AND SET ON 3/4" (19) CENTERS WITH ROD AND MULLION SUPPORTS. (1) MULLION IS USED ON SIZES 21-40. (2) MULLIONS ARE USED ON SIZES 41-48.
2. CONSTRUCTION IS 16GA STEEL FRAME WITH EXTRUDED ALUMINUM BLADES.
3. OPTIONAL OBD SHIPS ATTACHED TO UNIT.
4. MAXIMUM SIZE OF A SINGLE CORE UNIT IS 48" x 48".
5. SCREW HOLE QUANTITY AND LOCATION WILL VARY WITH UNIT SIZE.
6. STANDARD FINISH IS #44 WHITE.

**DIMENSIONS ARE GIVEN AS  
 INCHES (MM)**