

JOB NAME _____
 ARCHITECT _____
 ENGINEER _____
 CONTRACTOR _____
 LOCATION _____

SUBMITTAL SHEET
 Form Number GS0221 Effective Date 12/04
 NEW



AF5880 SUPPLY GRILLE
DOUBLE DEFLECTION ADJUSTABLE AIRFOIL BLADE

- AF5880H w/ OBD
- AF5880V w/ OBD

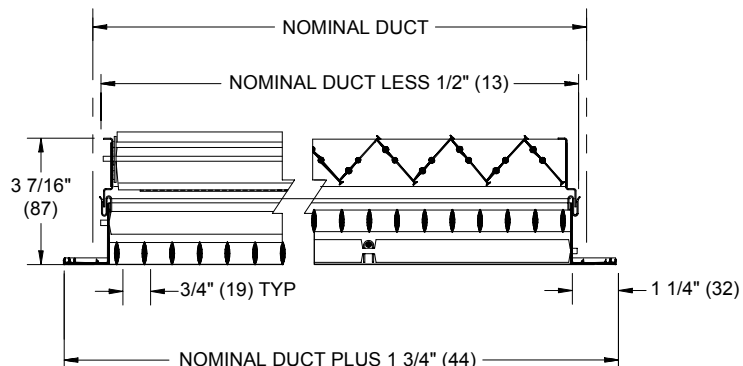

CENTER CROSS SECTION w/ OBD

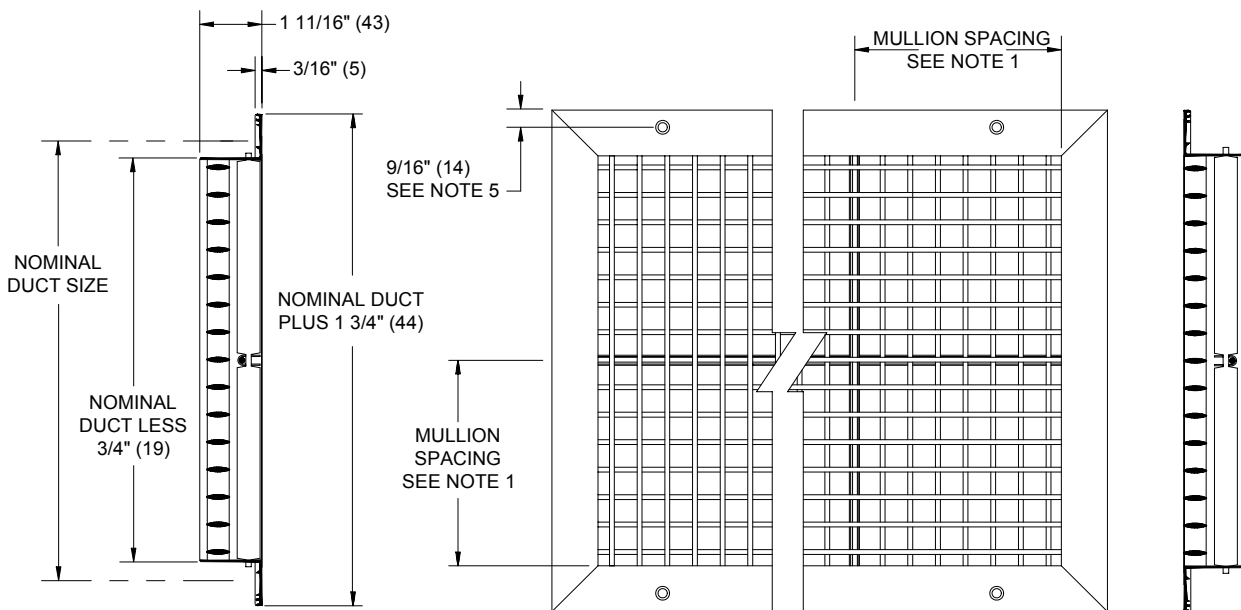

- AF5880V
CROSS SECTION

FACE VIEW VIEWS

- AF5880H
CROSS SECTION

NOTES :

1. H OR V DESIGNATES HORIZONTAL OR VERTICAL FRONT BLADES. ALL BLADES ARE ADJUSTABLE AND SET ON 3/4 " (19) CENTERS WITH ROD AND MULLION SUPPORTS.
 (1) MULLION IS USED ON SIZES 21-40.
 (2) MULLIONS ARE USED ON SIZES 41-48.
2. CONSTRUCTION IS ALUMINUM WITH EXTRUDED BLADES AND FRAME.
3. OPTIONAL OBD/5OBD SHIPS ATTACHED TO UNIT.
4. MAXIMUM SIZE OF A SINGLE CORE UNIT IS 48" x 48".
5. SCREW HOLE QUANTITY AND LOCATION WILL VARY WITH UNIT SIZE.
6. STANDARD FINISH IS #44 WHITE.

DIMENSIONS ARE GIVEN AS INCHES (MM)