

**RadiaFlo RFHF Series**  
 2-Way, 180°, Radial Air Diffusion

**SUBMITTAL SHEET**

UNIT SIZE		NECK SIZE
48" X 24"	24" X 24"	
<input type="checkbox"/> 10"	<input type="checkbox"/> 08"	
<input type="checkbox"/> 12"	<input type="checkbox"/> 10"	

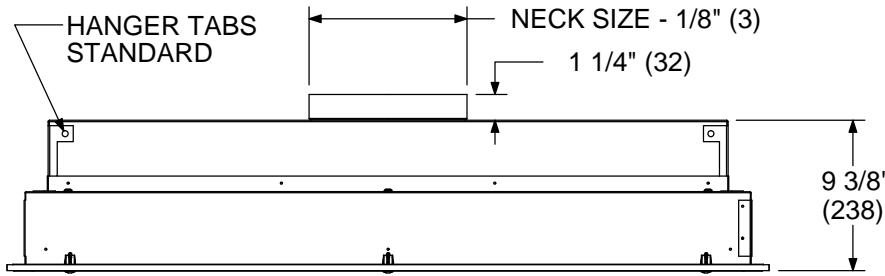
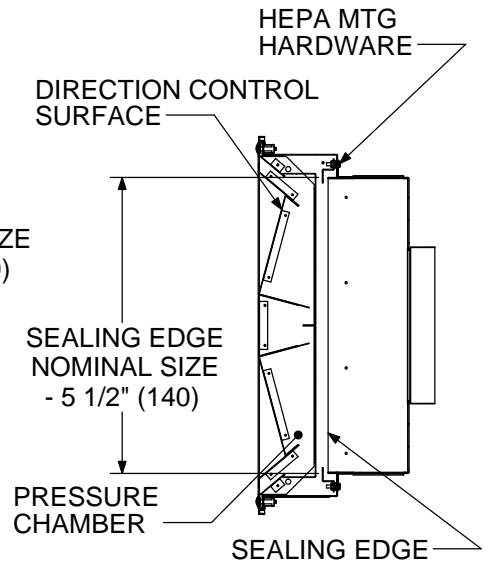
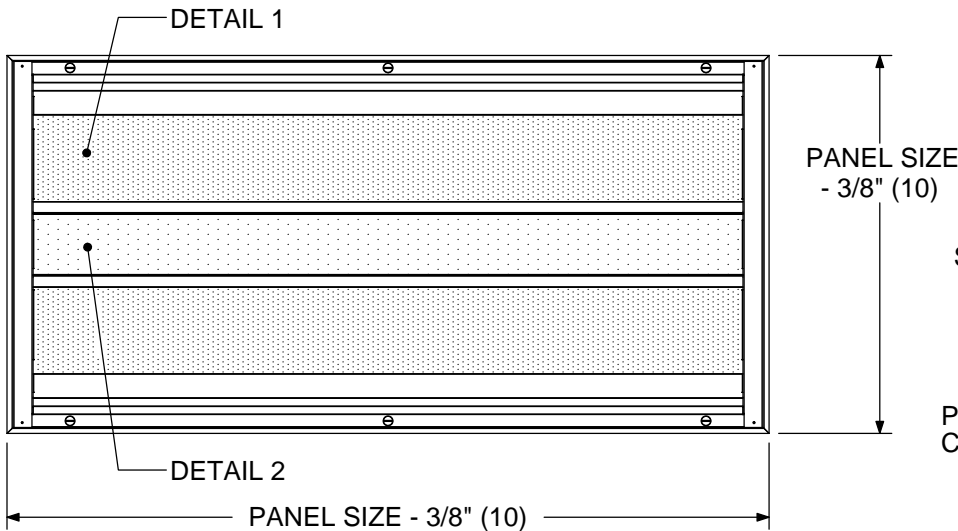

MATERIAL:  ALUMINUM (5RF)  STAINLESS (9RF)

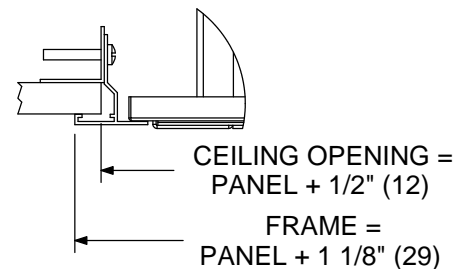
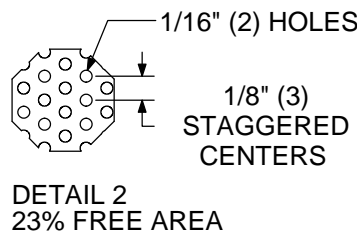
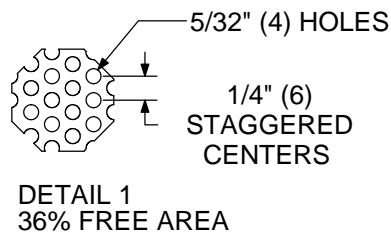
**NOTES:**

- NON-INTRUSIVE FACE DESIGN
- FACE AND BACKPAN ARE COMPLETE ASSEMBLY
- MULTIPLE PANEL PERFORATED FACE FOR SUPERIOR PERFORMANCE
- FACE IS EASILY REMOVABLE FOR CLEANING UTILIZING 1/4 TURN FASTENERS
- AVAILABLE IN ALUMINUM OR STAINLESS CONSTRUCTION
- AVAILABLE IN 48"X24" OR 24"X24" PANEL--SEE CHART FOR NECK SIZES
- T-BAR MOUNT (F23) STANDARD. OPTIONAL HARD CEILING MOUNT (F22) WITH SUPPLIED 5HCF23 FRAME

DIMENSIONS GIVEN AS INCHES (MM)

