

TAD Series

This series of radial face, critical room supply diffusers offer 90° or 180° air patterns. Available in aluminum or stainless steel construction. A HEPA filter backpan model is also available.



Radiaflo™ Series

This series of flush face, radial critical room supply diffusers offer a 180° air pattern. Available in aluminum or stainless steel construction. A HEPA filter backpan model is also available.



Steriflo®

Steriflo® is a stainless steel operating room system consisting of center and perimeter panels yielding exceptional particulate control.



Steriflex™

Steriflex™ is a modular, aluminum operating room system consisting of center and perimeter panels yielding exceptional particulate control.



5000, 5000HF

The 5000 series are low velocity, non-aspirating, perforated laminar flow panels with aluminum, stainless steel, and cold rolled steel construction. A HEPA filter backpan model is also available.



CRFF Series

The CRFF series of critical room fan filter units feature PSC or ECM motors and multiple filter options.

TAD, TADSS, TADHF, TADSSHF, TAD Backpan

Introduction B3-3
 Dimensional Information B3-7
 Mounting Details B3-10
 Installation Details B3-11
 Operational Balancing Data B3-13
 Performance Data B3-14
 Engineering Specification B3-16

Radiaflo™ (5RF, 5RFHF, 9RF, 9RFHF)

Introduction B3-19
 Dimensional Information B3-20
 Performance Data B3-25
 Engineering Specification B3-27

Steriflo®

Introduction B3-29
 Design Criteria B3-33
 System Components B3-36
 Performance Data B3-37
 Engineering Specification B3-38

Steriflex™

Introduction B3-39
 Design Criteria B3-41
 Dimensional Information B3-42
 Performance Data B3-45
 Engineering Specification B3-46

5000/5000HF

Introduction B3-47
 Dimensional Information B3-48
 Installation Details B3-51
 Performance Data B3-52
 Design Guide Examples B3-53
 Engineering Specification B3-56

CRFF Series

Introduction B3-58
 Dimensional Information B3-59
 Performance Data B3-61
 Engineering Specification B3-62

Introduction: Radiaflo™ (5RF, 5RFHF, 9RF, 9RFHF)

The Radiaflo™ is a flush faced radial flow diffuser designed for critical spaces with stringent ventilation requirements. It features a non-aspirating, forced displacement, radial air distribution design. Air flows from the Radiaflo™ diffuser in a radial pattern, displacing large volumes of air out and away from the diffuser. This forced displacement of air prevents entrainment of room air which may be contaminated with pollutants, making it an excellent choice for clean air environment applications. With proper application, the Radiaflo™ provides superior draft reduction for high air change rate environments such as animal rooms, laboratories, and hospitals. Additionally, the Radiaflo's aluminum and stainless steel construction options make the Radiaflo™ diffuser an great choice for corrosive environments. The Krueger Technology Center is well equipped for Radiaflo™ performance demonstrations. Virtually any application can be modeled in this facility.

MODEL

- 5RF - Flush Face Critical Room Supply Diffuser; Aluminum Construction
- 5RFHF - Flush Face Critical Room Supply Diffuser with HEPA Filter Brackets and Backpan; Aluminum Construction
- 9RF - Flush Face Critical Room Supply Diffuser; Stainless Steel Construction
- 9RFHF - Flush Face Critical Room Supply Diffuser with HEPA Filter Brackets and Backpan; Stainless Steel Construction
- RFFILTER - HEPA Filter for 5RFHF and 9RFHF

FEATURES

- 90° and 180° discharge air patterns.
- Removable flush face.
- High volume, draft free.

OPTIONS

- Surface mounting frames.
- 24"x24" and 24"x48" panel sizes.

FINISHES

- Standard finish is #44 British White.
- Optional finishes available.



Radiaflo™ (Face View, 180°)



Radiaflo™ (Isometric View, 180°)



Radiaflo™ (Face View, 90°)

Radioflo™ (5RF, 9RF) Dimensional Information

CRITICAL ROOM PRODUCTS

5RF, 9RF, 180° FACE VIEW

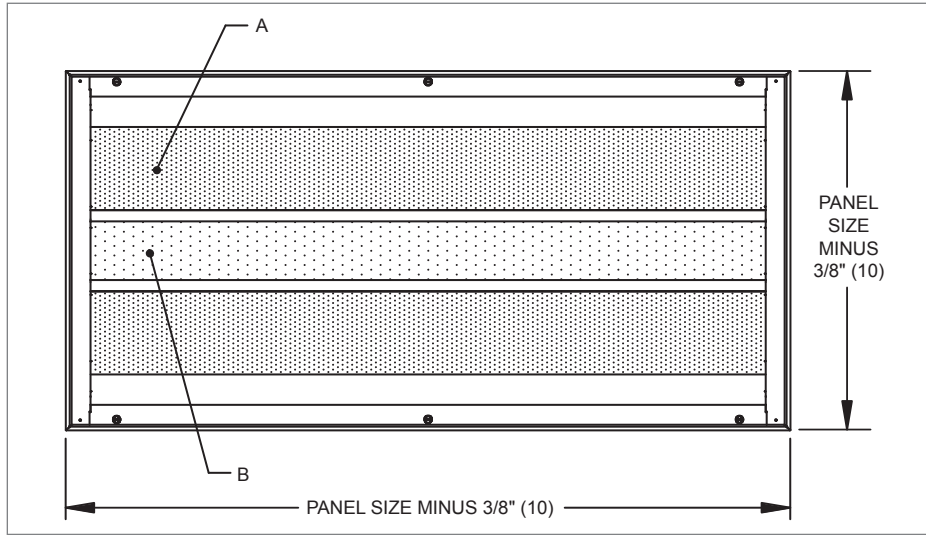

5RF, 9RF, 180° CROSS SECTION

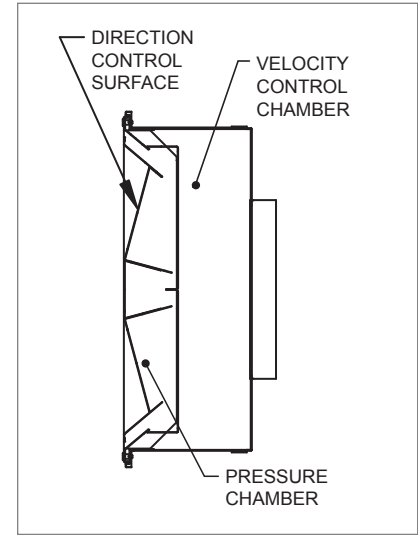

5RF/9RF, 180° SIDE VIEW

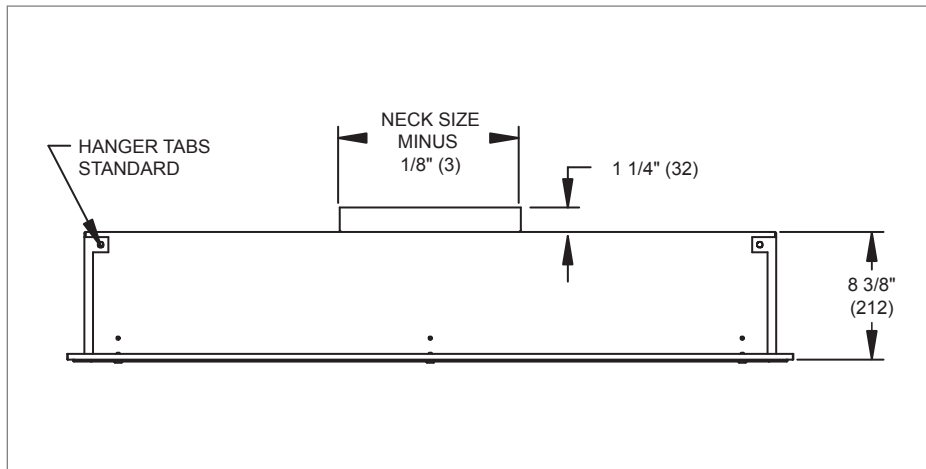

5RF, 9RF, 180° SURFACE MOUNT

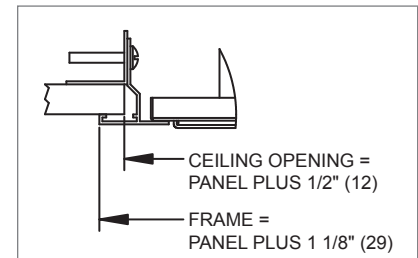

5RF, 9RF, 180° LAY-IN T-BAR

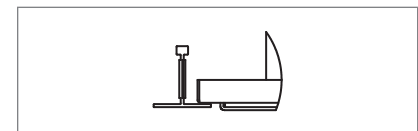

5RF, 9RF, 180° PERFORATION DETAIL A

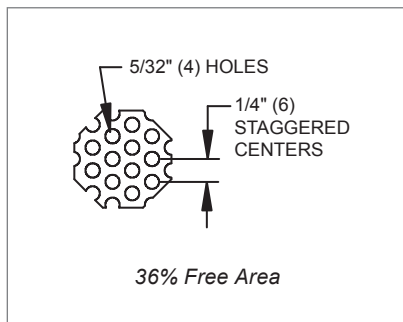

5RF, 9RF, 180° PERFORATION DETAIL B

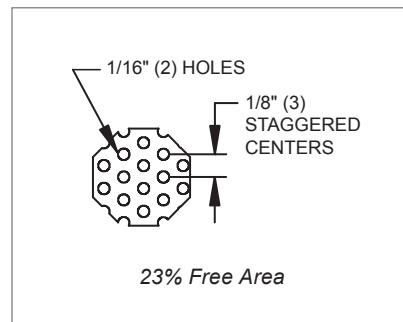

5RF, 9RF, 180° SAFETY CABLES

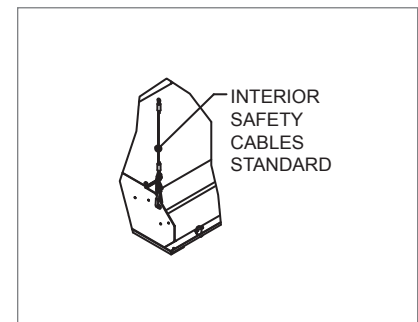

5RF, 9RF, 180° AVAILABLE SIZES

Unit Size	48"x24"	24"x24"
Neck Size	10" (245)	8" (196)
	12" (294)	10" (245)

NOTE: Dimensions in parentheses are mm.

R
A
D
I
A
F
L
O

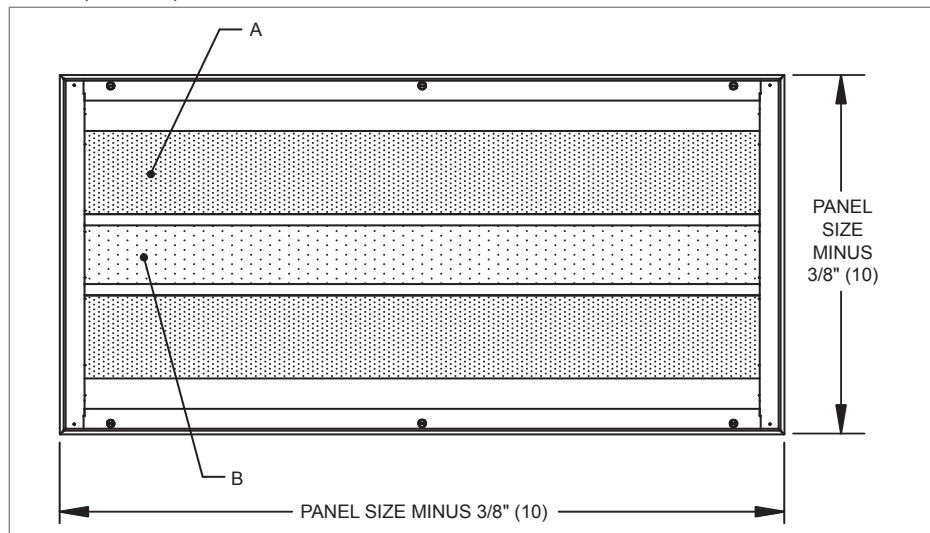
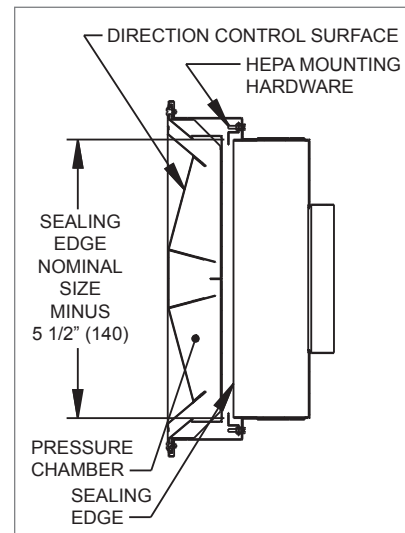
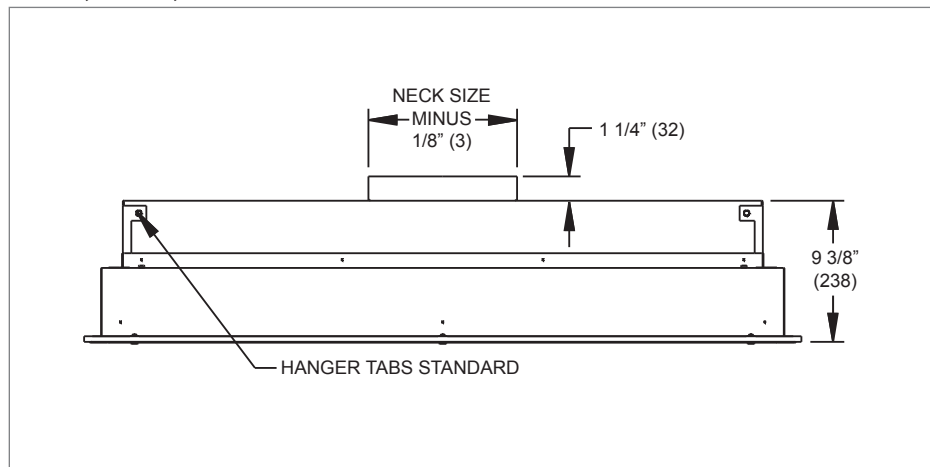
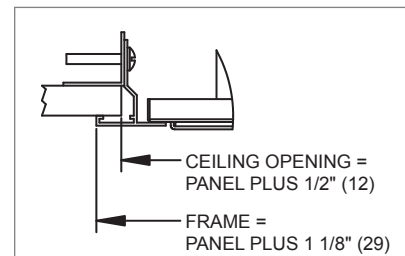
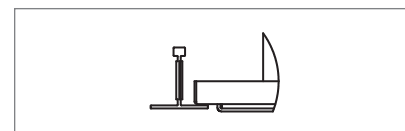
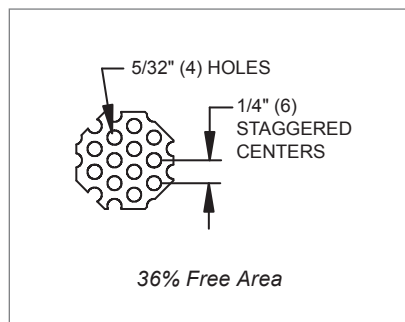
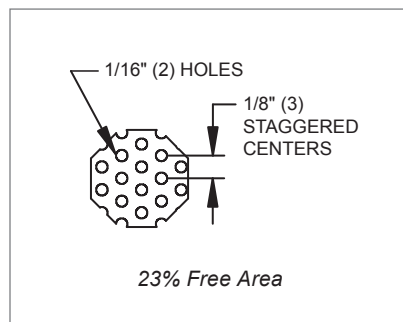
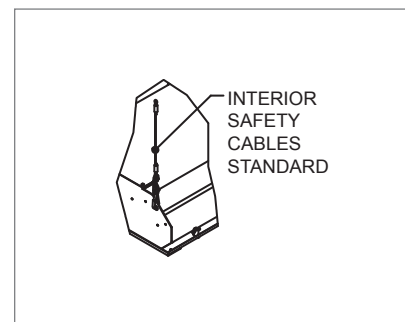
Radiaflo™ (5RFHF, 9RFHF) Dimensional Information
5RFHF, 9RFHF, 180° FACE VIEW

5RFHF, 9RFHF, 180° CROSS SECTION

5RFHF, 9RFHF, 180° SIDE VIEW

5RFHF, 9RFHF, 180° SURFACE MOUNT

5RFHF, 9RFHF, 180° LAY-IN T-BAR

5RFHF, 9RFHF, 180° PERFORATION DETAIL A

5RFHF, 9RFHF, 180° PERFORATION DETAIL B

5RFHF, 9RFHF, 180° SAFETY CABLES

5RFHF, 9RFHF, 180° AVAILABLE SIZES

Unit Size	48"x24"	24"x24"
Neck Size	10" (245)	8" (196)
	12" (294)	10" (245)

NOTE: Dimensions in parentheses are mm.

CRITICAL ROOM PRODUCTS

 R
A
D
I
A
F
L
O

© KRUEGER 2012

Radioflo™ (5RF, 9RF) Dimensional Information

CRITICAL ROOM PRODUCTS

5RF, 9RF, 90° FACE VIEW

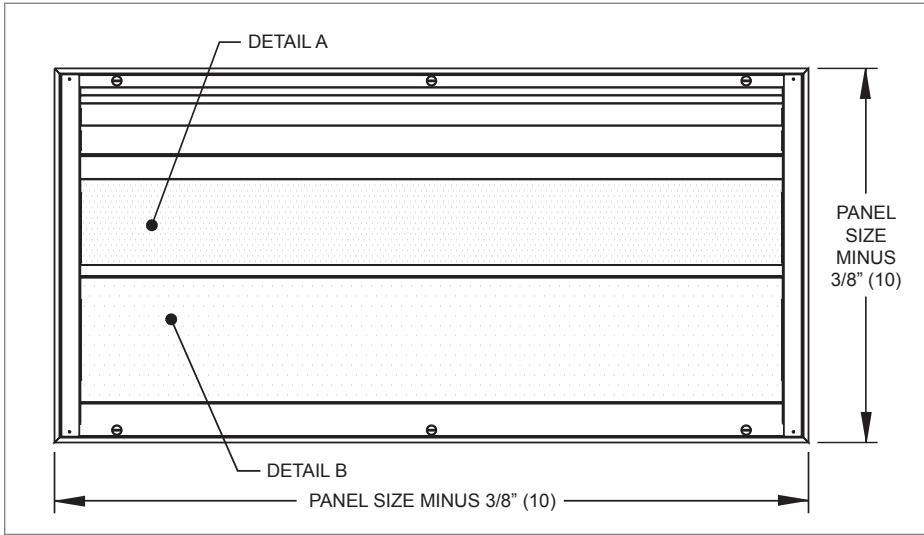

5RF, 9RF, 90° CROSS SECTION

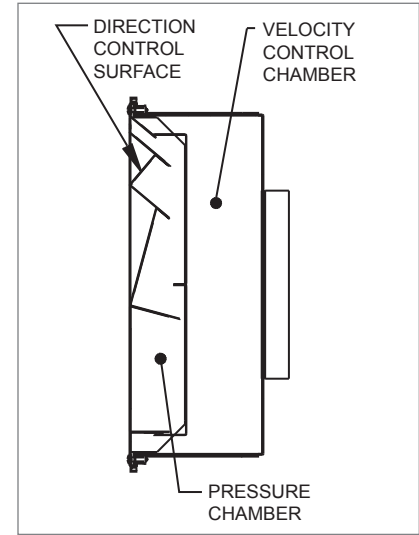

5RF, 9RF, 90° SIDE VIEW

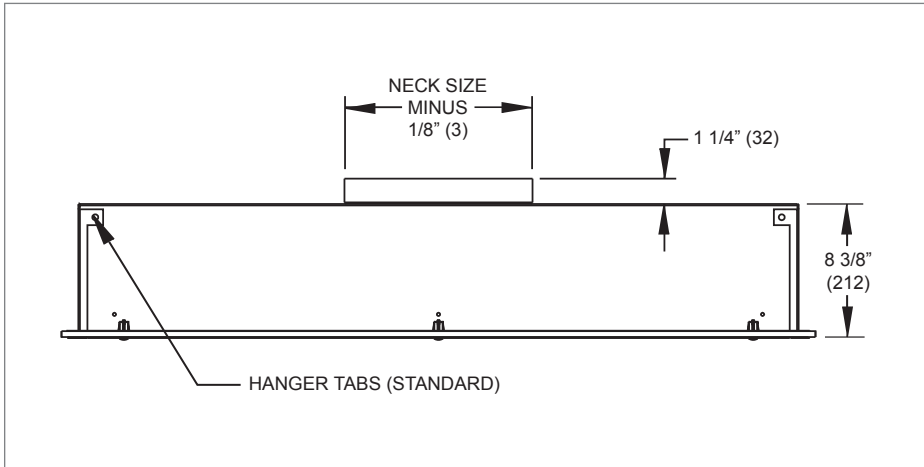

5RF, 9RF, 90° SURFACE MOUNT

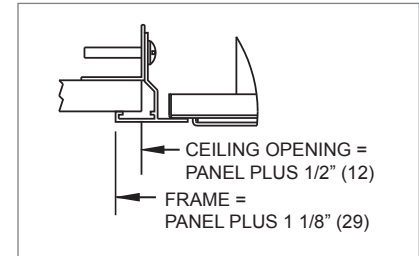

5RF, 9RF, 90° LAY-IN T-BAR

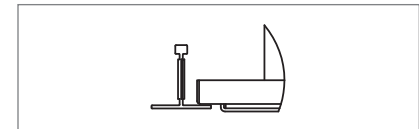

5RF, 9RF, 90° PERFORATION DETAIL A

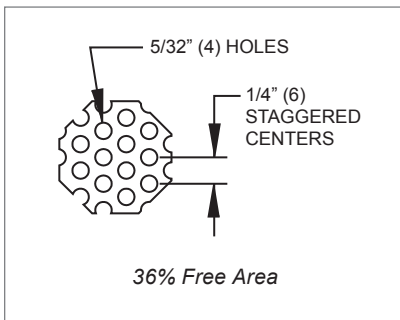

5RF, 9RF, 90° PERFORATION DETAIL B

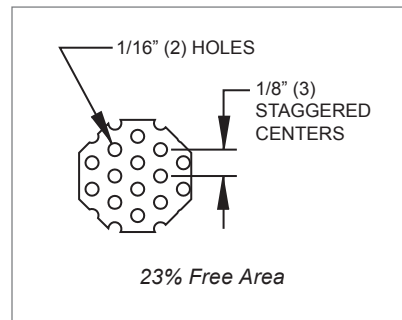

5RF, 9RF, 90° SAFETY CABLES

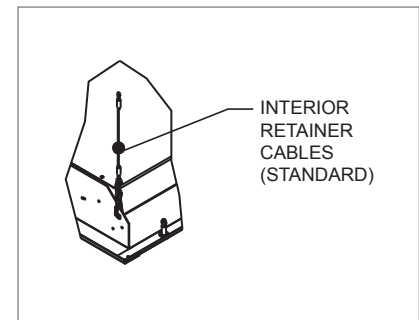

5RF, 9RF, 90° AVAILABLE SIZES

Unit Size	48"x24"	24"x24"
Neck Size	10" (245)	8" (196)
	12" (294)	10" (245)

NOTE: Dimensions in parentheses are mm.

R
A
D
I
A
F
L
O

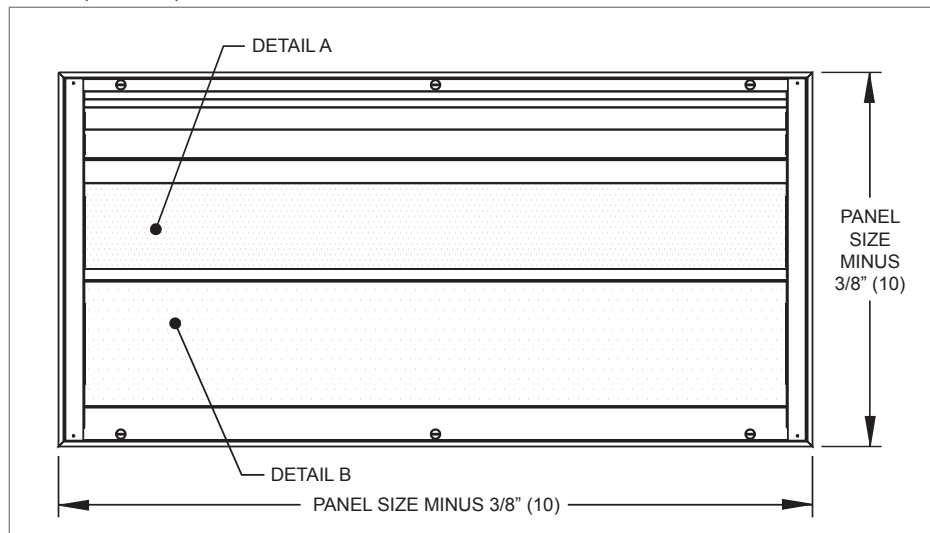
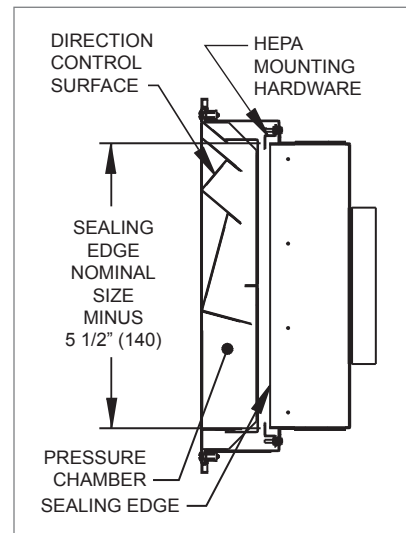
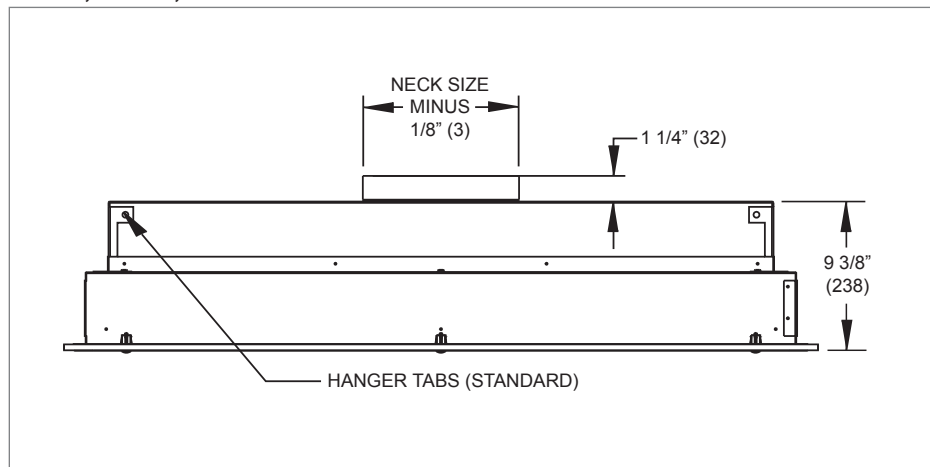
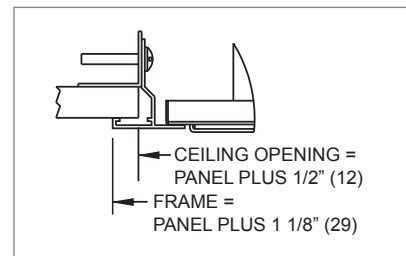
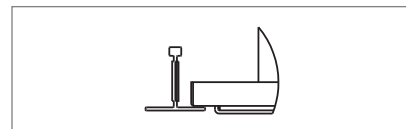
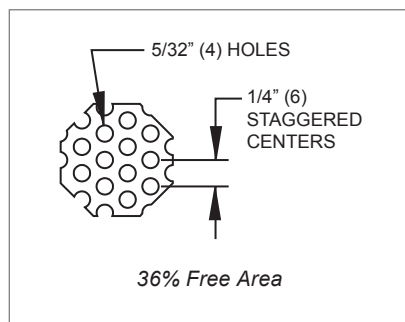
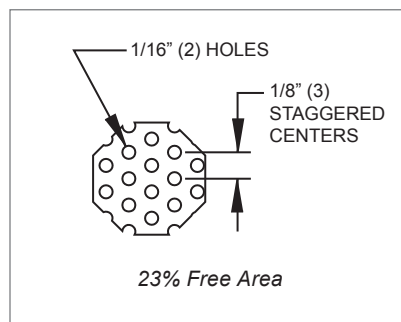
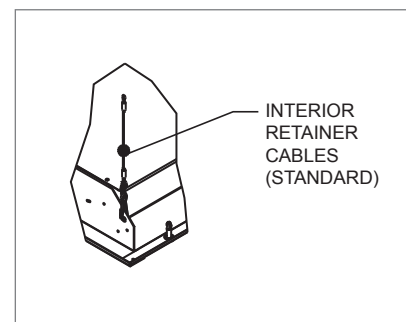
Radioflo™ (5RFHF, 9RFHF) Dimensional Information
5RFHF, 9RFHF, 90° FACE VIEW

5RFHF, 9RFHF, 90° CROSS SECTION

5RFHF, 9RFHF, 90° SIDE VIEW

5RFHF, 9RFHF, 90° SURFACE MOUNT

5RFHF, 9RFHF, 90° LAY-IN T-BAR

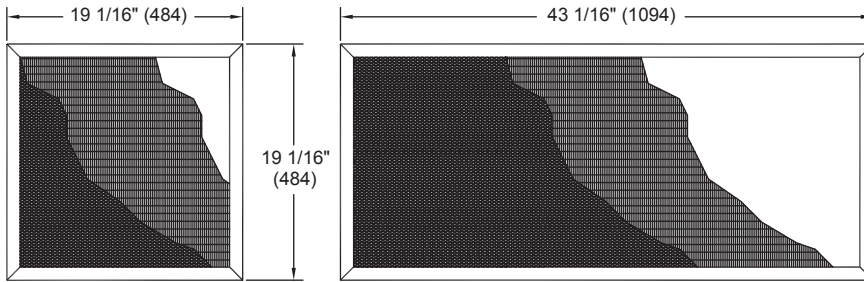
5RFHF, 9RFHF, 90° PERFORATION DETAIL A

5RFHF, 9RFHF, 90° PERFORATION DETAIL B

5RFHF, 9RFHF, 90° SAFETY CABLES

5RFHF, 9RFHF, 90°, AVAILABLE SIZES

Unit Size	48"x24"	24"x24"
Neck Size	10" (245)	8" (196)
	12" (294)	10" (245)

NOTE: Dimensions in parentheses are mm.

RFFILTER Dimensional Information

RFFILTER, 24"x24" & 24"x48" PANEL FACE AND SIDE VIEWS



24"x24" NOMINAL PANEL

48"x24" NOMINAL PANEL

STANDARD FEATURES:

1. 99.99% Minimum Efficiency.
2. Each filter is tested and certified.
3. Anodized extruded aluminum frame.
4. Lightweight and compact.
5. Gel pocket provides airtight seal around edges.
6. Mini-pleat design features maximum media cleaning potential.
7. Classified under UL 900 and UL 586.

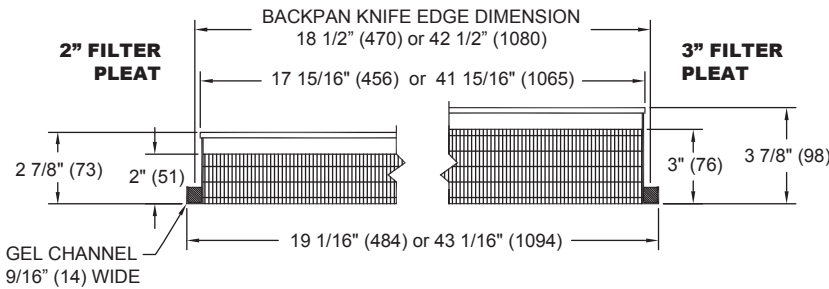

RFFILTER, INSTALLATION VIEW

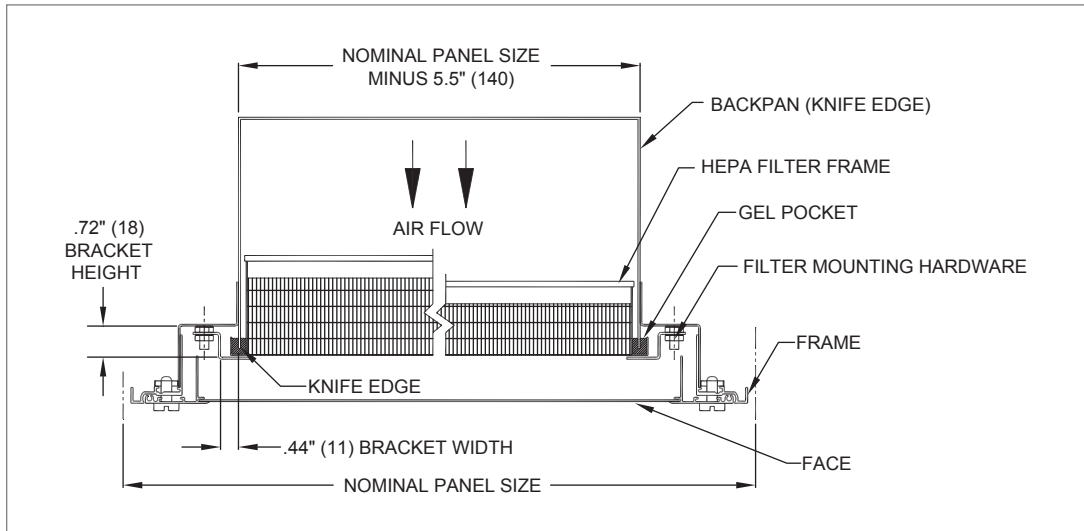

CRITICAL ROOM PRODUCTS

R
A
D
I
A
F
L
O

Radioflo™ (5RF, 5RFHF, 9RF, 9RFHF) Performance Data

IP DATA: 5RF, 5RFHF, 9RF, 9RFHF, 180°

Throw Pattern	Panel Size		Inlet Dia.	Neck Vel	Air Flow	Pt	Ps	Δ T	Throw (ft @ FPM)					Sound
	W	L							Horizontal		Max	Vertical		
	in	in							100	50	50	100	50	
180° (2-Way)	24	24	8	860	300	0.074	0.027	-5	1	4	6	3	5	24
				1146	400	0.131	0.049		2	4	7	3	5	32
				1433	500	0.204	0.076		3	5	8	3	6	38
	24	24	8	860	300	0.074	0.027	-15	2	4	7	6	8	24
				1146	400	0.131	0.049		2	5	8	7	8	32
				1433	500	0.204	0.076		3	6	9	8	9	38
180° (2-Way)	24	24	10	550	300	0.041	0.022	-5	2	4	6	3	6	<20
				963	525	0.126	0.069		3	5	8	3	6	30
				1376	750	0.258	0.140		6	8	10	8	9	40
	24	24	10	550	300	0.041	0.022	-15	2	4	7	6	8	<20
				963	525	0.126	0.069		4	6	9	8	9	30
				1376	750	0.258	0.140		5	8	10	9	-	40
180° (2-Way)	24	48	10	917	500	0.096	0.044	-5	2	3	5	4	6	25
				1193	650	0.163	0.074		2	3	6	4	6	32
				1468	800	0.246	0.112		3	4	8	3	8	38
	24	48	10	917	500	0.096	0.044	-15	2	3	9	5	9	25
				1193	650	0.163	0.074		2	3	9	5	9	32
				1468	800	0.246	0.112		2	4	8	4	8	38
180° (2-Way)	24	48	12	802	600	0.090	0.050	-5	2	3	7	2	6	20
				1070	800	0.160	0.089		4	5	9	3	6	29
				1337	1000	0.250	0.139		5	6	12	6	8	36
	24	48	12	802	600	0.090	0.050	-15	2	3	9	7	9	20
				1070	800	0.160	0.089		4	6	9	7	9	29
				1337	1000	0.250	0.139		6	8	13	7	-	36

METRIC DATA: 5RF, 5RFHF, 9RF, 9RFHF, 180°

Throw Pattern	Panel Size		Inlet Dia.	Neck Vel	Air Flow	Pt	Ps	Δ T	Throw (m @ m/s)					Sound
	W	L							Horizontal		Max	Vertical		
	cm	cm							0.5	0.25	0.25	0.5	0.25	
180° (2-Way)	61.0	61.0	20.3	4.37	142	18.3	6.8	-2.8	0.3	1.2	1.8	0.9	1.5	24
				5.82	189	32.5	12.2		0.6	1.2	2.1	0.9	1.5	32
				7.28	236	50.8	19.0		0.9	1.5	2.4	0.9	1.8	38
	61.0	61.0	20.3	4.37	142	18.3	6.8	-8.3	0.6	1.2	2.1	1.8	2.4	24
				5.82	189	32.5	12.2		0.6	1.5	2.4	2.1	-	32
				7.28	236	50.8	19.0		0.9	1.8	2.7	2.4	-	38
180° (2-Way)	61.0	61.0	25.4	2.80	142	10.3	5.6	-2.8	0.6	1.2	1.8	0.9	1.8	<20
				4.89	248	31.5	17.1		0.9	1.5	2.4	0.9	1.8	30
				6.99	354	64.2	34.8		1.8	2.4	3.0	2.4	2.7	40
	61.0	61.0	25.4	2.80	142	10.3	5.6	-8.3	0.6	1.2	2.1	1.8	2.4	<20
				4.89	248	31.5	17.1		1.2	1.8	2.7	2.4	-	30
				6.99	354	64.2	34.8		1.5	2.4	3.0	2.7	-	40
180° (2-Way)	61.0	121.9	25.4	4.66	236	24.0	10.9	-2.8	0.6	0.9	1.5	1.2	1.8	25
				6.06	307	40.5	18.4		0.6	0.9	1.8	1.2	1.8	32
				7.46	378	61.3	27.9		0.9	1.2	2.4	0.9	2.4	38
	61.0	121.9	25.4	4.66	236	24.0	10.9	-8.3	0.6	0.9	2.7	1.5	2.7	25
				6.06	307	40.5	18.4		0.6	0.9	2.7	1.5	2.7	32
				7.46	378	61.3	27.9		0.6	1.2	2.4	1.2	2.4	38
180° (2-Way)	61.0	121.9	30.5	4.07	283	22.4	12.4	-2.8	0.6	0.9	2.1	0.6	1.8	20
				5.43	378	39.9	22.1		1.2	1.5	2.7	0.9	1.8	29
				6.79	472	62.3	34.5		1.5	1.8	3.6	1.8	2.4	36
	61.0	121.9	30.5	4.07	283	22.4	12.4	-8.3	0.6	0.9	2.7	2.1	2.7	20
				5.43	378	39.9	22.1		1.2	1.8	2.7	2.1	2.7	29
				6.79	472	62.3	34.5		1.8	2.4	4.0	2.1	-	36

NOTES: Air distribution is strongly affected by the temperature difference between supply and room air (ΔT). In most cases, the unit supplies air colder than the room, typically at about -3°C ΔT. Return air should be exhausted with low sidewall return grilles for optimum performance.

Radioflo™ (5RF, 5RFHF, 9RF, 9RFHF) Performance Data

IP DATA: 5RF, 5RFHF, 9RF, 9RFHF, 90°

CRITICAL ROOM PRODUCTS

Throw Pattern	Panel Size		Inlet Dia in	Neck Vel FPM	Air Flow CFM	Pt "WG	Ps "WG	Δ T R	Throw, ft @ fpm					Sound NC
	W	L							Horizontal		Max	Vertical		
	in	in							100	50	50	100	50	
90° (1-Way)	24	24	8	860	300	0.137	0.091	-5	2	3	3	1	2	<20
				1146	400	0.244	0.162		4	5	5	1	2	23
				1433	500	0.381	0.253		5	6	6	1	3	27
	24	24	8	860	300	0.137	0.091	-15	2	3	4	2	3	<20
				1146	400	0.244	0.162		4	5	6	3	5	23
				1433	500	0.381	0.253		5	7	8	4	7	27
90° (1-Way)	24	24	10	550	300	0.061	0.042	-5	3	4	3	1	2	<20
				734	400	0.109	0.075		5	6	7	2	3	<20
				917	500	0.170	0.117		5	8	8	3	4	19
	24	24	10	550	300	0.061	0.042	-15	3	4	5	1	3	<20
				734	400	0.109	0.075		5	6	7	4	7	<20
				917	500	0.170	0.117		5	6	8	6	7	19
90° (1-Way)	24	48	10	917	500	0.136	0.083	-5	2	3	4	2	4	27
				1193	650	0.230	0.141		2	4	4	2	4	33
				1468	800	0.348	0.214		2	5	6	3	5	39
	24	48	10	917	500	0.136	0.083	-15	2	3	5	2	5	27
				1193	650	0.230	0.141		2	4	7	2	6	33
				1468	800	0.348	0.214		2	6	9	5	7	39
90° (1-Way)	24	48	12	764	600	0.128	0.092	-5	1	3	4	1	4	21
				1019	800	0.228	0.163		3	4	5	3	5	30
				1274	1000	0.357	0.255		3	7	9	9	-	37
	24	48	12	764	600	0.128	0.092	-15	2	3	4	2	4	21
				1019	800	0.228	0.163		3	4	5	4	5	30
				1274	1000	0.357	0.255		4	8	9	-	-	37

METRIC DATA: 5RF, 5RFHF, 9RF, 9RFHF, 90°

Throw Pattern	Panel Size		Inlet Dia cm	Neck Vel m/s	Air Flow L/s	Pt Pa	Ps Pa	Δ T K	Throw, m, @ m/s					Sound NC
	W	L							Horizontal		Max	Vertical		
	cm	cm							0.5	0.3	0.3	0.5	0.3	
90° (1-Way)	61.0	61.0	20.3	4.37	142	34.2	22.7	-2.8	0.6	0.9	0.9	0.3	0.6	<20
				5.82	189	60.7	40.3		1.2	1.5	1.5	0.3	0.6	23
				7.28	236	94.9	63.0		1.5	1.8	1.8	0.3	0.9	27
	61.0	61.0	20.3	4.37	142	34.2	22.7	-8.3	0.6	0.9	1.2	0.6	0.9	<20
				5.82	189	60.7	40.3		1.2	1.5	1.8	0.9	0.0	23
				7.28	236	94.9	63.0		1.5	2.1	2.4	1.2	0.0	27
90° (1-Way)	61.0	61.0	25.4	2.79	142	15.2	10.5	-2.8	0.9	1.2	0.9	0.3	0.6	<20
				3.73	189	27.1	18.7		1.5	1.8	2.1	0.6	0.9	<20
				4.66	236	42.3	29.2		1.5	2.4	2.4	0.9	1.2	19
	61.0	61.0	25.4	2.79	142	15.2	10.5	-8.3	0.9	1.2	1.5	0.3	0.9	<20
				3.73	189	27.1	18.7		1.5	1.8	2.1	1.2	0.0	<20
				4.66	236	42.3	29.2		1.5	1.8	2.4	1.8	0.0	19
90° (1-Way)	61.0	121.9	25.4	4.66	236	33.8	20.8	-2.8	0.6	0.9	1.2	0.6	1.2	27
				6.06	307	57.3	35.2		0.6	1.2	1.2	0.6	1.2	33
				7.46	378	86.7	53.3		0.6	1.5	1.8	0.9	1.5	39
	61.0	121.9	25.4	4.66	236	33.8	20.8	-8.3	0.6	0.9	1.5	0.6	1.5	27
				6.06	307	57.3	35.2		0.6	1.2	2.1	0.6	1.8	33
				7.46	378	86.7	53.3		0.6	1.8	2.7	1.5	2.1	39
90° (1-Way)	61.0	121.9	30.5	3.88	283	31.9	22.9	-2.8	0.3	0.9	1.2	0.3	1.2	21
				5.18	378	56.8	40.7		0.9	1.2	1.5	0.9	1.5	30
				6.47	472	88.8	63.6		0.9	2.1	2.7	2.7	-	37
	61.0	121.9	30.5	3.88	283	31.9	22.9	-8.3	0.6	0.9	1.2	0.6	1.2	21
				5.18	378	56.8	40.7		0.9	1.2	1.5	1.2	1.5	30
				6.47	472	88.8	63.6		1.2	2.4	2.7	-	-	37

NOTES: Air distribution is strongly affected by the temperature difference between supply and room air (ΔT). In most cases, the unit supplies air colder than the room, typically at about -3°C ΔT. Return air should be exhausted with low sidewall return grilles for optimum performance.

RADIOFLO

© KRUEGER 2012

Radiaflo™ 180° (5RF, 5RFHF, 9RF, 9RFHF) Suggested Specification & Configuration —
1. SERIES: (XXXXX)

- 5RF - Flush Face Critical Room Supply Diffuser, Aluminum Construction
- 5RFHF - Flush Face Critical Room Supply Diffuser with HEPA Filter Brackets and Backpan; Aluminum Construction
- 9RF - Flush Face Critical Room Supply Diffuser, Stainless Steel Construction
- 9RFHF - Flush Face Critical Room Supply Diffuser with HEPA Filter Brackets; Backpan and Face in Stainless Steel Construction Only

2. PATTERN: (XX)

- 02 - 180° or 2-Way Air Discharge

3. INLET SIZE: (XX)

- 08" - Uses 24"x24" Panel Size Only
- 10" - Uses 24"x24" & 48"x24" Panel Sizes
- 12" - Uses 48"x24" Panel Size Only

4. FRAME: (XXX)

- F22 - Surface Mount *
- F23 - Lay-in T-Bar

5. PANEL SIZE: (XX)x(XX)

- 24"x24"
- 48"x24"

6. BACKPAN CONSTRUCTION: (XX)

- 01 - Cold Rolled Steel
- 02 - Aluminum
- 03 - Stainless Steel

7. FINISH: (XX)

- 01 - Mill
- 07 - Enamel **
- 09 - Epoxy **
- 10 - Alumican
- 35 - Black
- 44 - British White
- 49 - Off White

* Frame 22 includes separate plaster frame, shipped loose for field installation (Model 5HCF23).

** Finish is to match color sample.

RADIAFLO™ (5RF, 5RFHF, 9RF, 9RFHF)

Provide where indicated on the drawings, a Krueger Model 5RF (aluminum) or 9RF (stainless steel) diffuser designed for non-aspirating, radial displacement. The diffuser face must be flush with the ceiling plane, incorporating a non-intrusive look, and distribute air in a 180° air pattern. The diffuser face shall incorporate a special geometric design that includes a velocity control chamber, pressure chamber, and directional control surfaces to achieve the desired 180° air pattern. The face of the Radiaflo™ shall be removable from the backpan by the use of 1/4 turn fasteners, even in lay-in ceiling applications. The backpan shall have a hanger tab at all four corners to permit attachment to overhead structure. The face of the Radiaflo™ shall be available in aluminum and stainless steel construction. The backpan shall be available in steel, aluminum, or stainless steel construction.

PERFORMANCE

The manufacturer shall provide published performance data for the diffuser. The diffuser shall be tested in accordance to the data standards at the time of product introduction or ANSI/ASHRAE Standard 70.

STANDARD FINISH

The paint finish shall be #44 British White, powder coat paint, baked at 425°F. The paint thickness shall be 2.0 – 3.0 mils, gloss at 60° per ASTM D523-89 of 60 – 70%, pencil hardness per ASTM D3363-92A of H – 2H, crosshatch adhesion per ASTM D3359-83 of 5B, salt spray per ASTM B117-9048 of 1000 hours, humidity per ASTM D2247-92 of 1000 hours and conical mandrel per ASTM D522 of 1/8" conical bend, no cracking shows.

ANTIMICROBIAL FINISH

The paint finish shall be powder coat paint, baked at 425°F. The paint thickness shall be 2.0 – 3.0 mils, gloss at 60° per ASTM D523-89 of 55 – 65%, pencil hardness per ASTM D3363-92A of H – 2H, crosshatch adhesion per ASTM D3359-83 of 5B, salt spray per ASTM B117-9048 of 1000 hours, humidity per ASTM D2247-92 of 1000 hours and conical mandrel per ASTM D522 of 1/8" conical bend, no cracking shows.

Radiaflo™ 90° (5RF, 5RFHF, 9RF, 9RFHF) Suggested Specification & Configuration
RADIAFLO™ (5RF, 5RFHF, 9RF, 9RFHF)

Provide where indicated on the drawings, a Krueger Model 5RF (aluminum) or 9RF (stainless steel) diffuser designed for non-aspirating, radial displacement. The diffuser face must be flush with the ceiling plane, incorporating a non-intrusive look, and distribute air in a 90° air pattern. The diffuser face shall incorporate a special geometric design that includes a velocity control chamber, pressure chamber, and directional control surfaces to achieve the desired 90° air pattern. The face of the Radiaflo™ shall be removable from the backpan by the use of 1/4 turn fasteners, even in lay-in ceiling applications. The backpan shall have a hanger tab at all four corners to permit attachment to overhead structure. The face of the Radiaflo™ shall be available in aluminum and stainless steel construction. The backpan shall be available in steel, aluminum, or stainless steel construction.

PERFORMANCE

The manufacturer shall provide published performance data for the diffuser. The diffuser shall be tested in accordance to the data standards at the time of product introduction or ANSI/ASHRAE Standard 70.

STANDARD FINISH

The paint finish shall be #44 British White, powder coat paint, baked at 425°F. The paint thickness shall be 2.0 – 3.0 mils, gloss at 60° per ASTM D523-89 of 60 – 70%, pencil hardness per ASTM D3363-92A of H – 2H, crosshatch adhesion per ASTM D3359-83 of 5B, salt spray per ASTM B117-9048 of 1000 hours, humidity per ASTM D2247-92 of 1000 hours and conical mandrel per ASTM D522 of 1/8" conical bend, no cracking shows.

ANTIMICROBIAL FINISH

The paint finish shall be powder coat paint, baked at 425°F. The paint thickness shall be 2.0 – 3.0 mils, gloss at 60° per ASTM D523-89 of 55 – 65%, pencil hardness per ASTM D3363-92A of H – 2H, crosshatch adhesion per ASTM D3359-83 of 5B, salt spray per ASTM B117-9048 of 1000 hours, humidity per ASTM D2247-92 of 1000 hours and conical mandrel per ASTM D522 of 1/8" conical bend, no cracking shows.

1. SERIES: (XXXXX)

- 5RF - Flush Face Critical Room Supply Diffuser, Aluminum Construction
- 5RFHF - Flush Face Critical Room Supply Diffuser with HEPA Filter Brackets and Backpan; Aluminum Construction
- 9RF - Flush Face Critical Room Supply Diffuser, Stainless Steel Construction
- 9RFHF - Flush Face Critical Room Supply Diffuser with HEPA Filter Brackets; Backpan and Face in Stainless Steel Construction Only

2. PATTERN: (XX)

- 01 - 90° or 1-Way Air Discharge

3. INLET SIZE: (XX)

- 08" - Uses 24"x24" Panel Size Only
- 10" - Uses 24"x24" & 48"x24" Panel Sizes
- 12" - Uses 48"x24" Panel Size Only

4. FRAME: (XXX)

- F22 - Surface Mount *
- F23 - Lay-in T-Bar

5. PANEL SIZE: (XX)x(XX)

- 24"x24"
- 48"x24"

6. BACKPAN CONSTRUCTION: (XX)

- 01 - Cold Rolled Steel
- 02 - Aluminum
- 03 - Stainless Steel

7. FINISH: (XX)

- 01 - Mill
- 07 - Enamel **
- 09 - Epoxy **
- 10 - Alumatican
- 35 - Black
- 44 - British White
- 49 - Off White

* Frame 22 includes separate plaster frame, shipped loose for field installation (Model 5HCF23).

** Finish is to match color sample.

SAMPLE CONFIGURATION: 9RF - 01 - 12 - F23 - 48x24 - 03 - 01