

Introduction: 1390

The 1390 series barrier bars feature a grid of bar work that has a maximum of 6" on center spacing. The 1390 is a great choice where penetration through a wall or ceiling needs to be secure and no requirement for duct work to be attached.

MODEL

1390 - Steel 3/4" diameter security bars with 2 1/2"x1/4" thick steel frame.

FEATURES

- 30"x30" Maximum single unit size.

OPTIONS

- Standard - Both 3/4" diameter vertical and 2 1/2"x1/4" flat horizontal bars.
- H Option - 2 1/2"x1/4" Flat horizontal bars on 6" centers (no vertical round bars).
- V Option - 3/4" Diameter vertical bars on 6" centers (no horizontal flat bars).

FINISHES

- Standard finish is #44 British White.
- Optional finish is Mill.

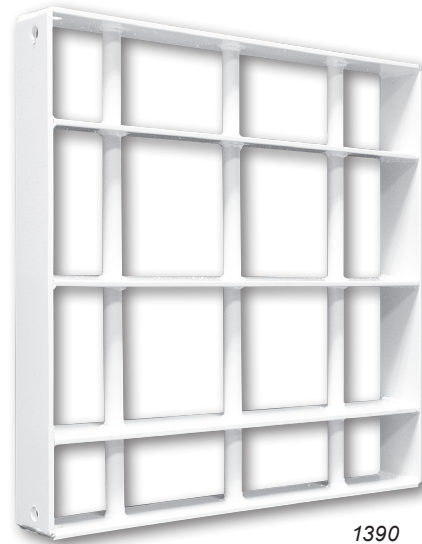

1390

1390 Dimensional Information

1390, FACE VIEW

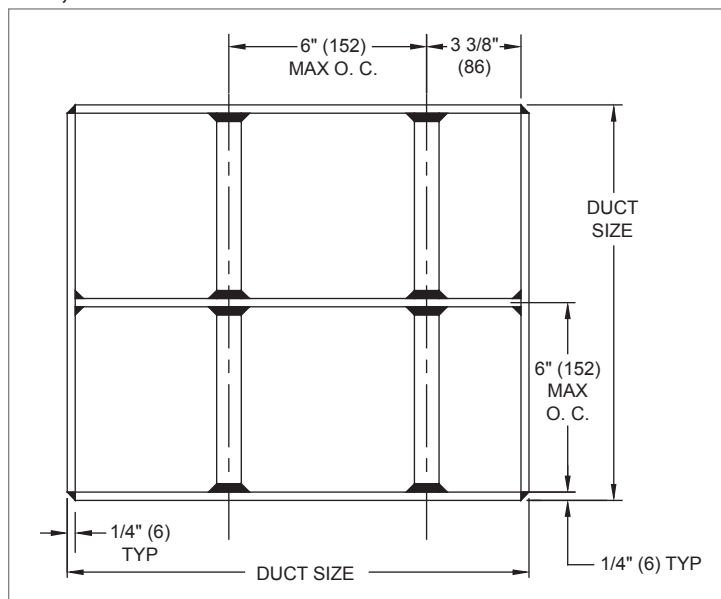

NOTE: Dimensions in parentheses are mm.

1390, CROSS SECTION

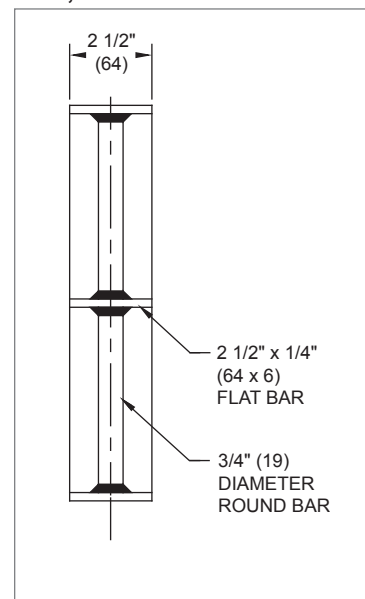

1390 Suggested Specification & Configuration

1390

The barrier grille shall be a Krueger model 1390. The barrier grille shall be constructed of 3/4" diameter steel vertical round bars and 2 1/2"x1/4" steel horizontal flat bars not to exceed 6" on center in either direction. The round bars passing through the horizontal flat bars shall be welded on one side of the flat bar at all intersections.

FINISH

The paint finish shall be #44 British White and be an anodic acrylic paint, baked at 315°F for 30 minutes. The paint thickness shall be 0.8 – 1.0 mils, gloss at 60° per ASTM D523-89 of 50 – 85%, pencil hardness per ASTM D3363-92A of HB – H, crosshatch adhesion per ASTM D3359-83 of 4B – 5B, impact per ASTM D2794-93 of direct impact >100 in/lb and reverse impact >80 in/lb, salt spray per ASTM B117-9048 of 96 hours, humidity per ASTM D2247-92 of >500 hours and water soak per ASTM D870-92 of 250 hours.

1. SERIES: (XXXX)

1390 - Security Barred Duct Work
with 2 1/2"x1/4" Frame

2. WIDTH: (XX)

6" - 30" in 1" Increments

3. HEIGHT: (XX)

4" - 30" in 1" Increments

4. ACCESSORIES: (X)

0 - Standard Unit - Includes Both 3/4" Diameter
Vertical and 2 1/2" x 1/4" Flat Horizontal Bars

H - 2 1/2"x1/4" Horizontal
Flat Bars Only on 6" Centers *

V - 3/4" Diameter Vertical Round
Bars Only on 6" Centers **

5. FINISH: (XX)

01 - Mill

44 - British White

* No vertical round bars.

** No horizontal flat bars.