

**Introduction: PRD100**
**MODEL**

PRD100 - Duct Mounted Radial Sliding Blade Damper with Adapter Ring, Heavy Gage Steel Construction

**FEATURES**

- Gang operated radial blades that slide at right angles to the duct to allow damper to work effectively in flexible duct applications.
- Operated by flat-head screwdriver through face.
- Shipped loose for field installation.

**FINISH**

- Standard finish is Mill.

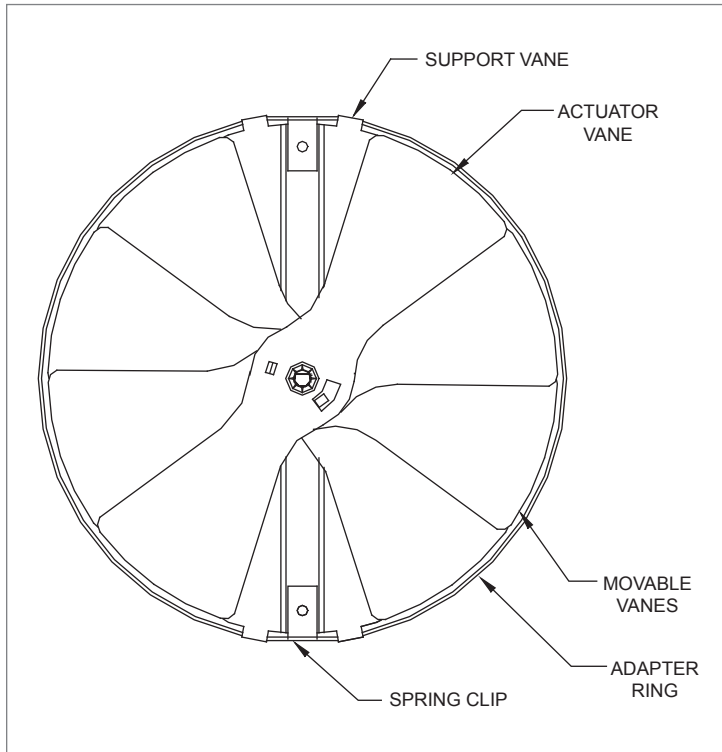
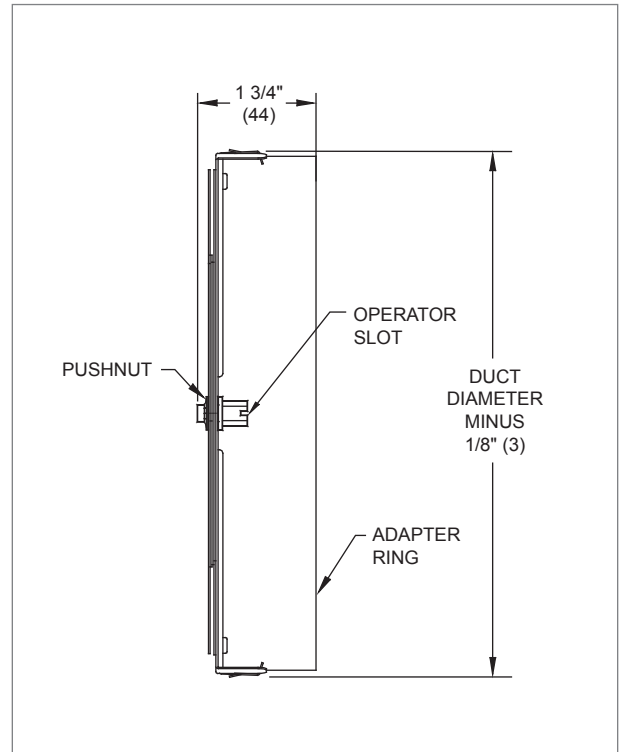

PRD100

**PRD100 Dimensional Information**
**PRD100, FACE VIEW**

**PRD100, CROSS SECTION**

**AVAILABLE SIZES**

Nominal Duct Diameter
6" (152)
7" (178)
8" (203)
10" (254)
12" (305)
14" (356)

NOTES: Dimensions in parentheses are mm.  
Reference page Q1-26 for applicable product.