

Introduction: OBDFA, 5OBDFA
MODELS

- OBDFA - Opposed Blade Damper, Steel Construction
- 5OBDFA - Opposed Blade Damper, Aluminum Construction

FEATURES

- Lever operated.
- Maximum single size damper is 15"x24" (381x610mm); multiple dampers used to create larger sizes.

FINISH

- Standard finish is Mill.

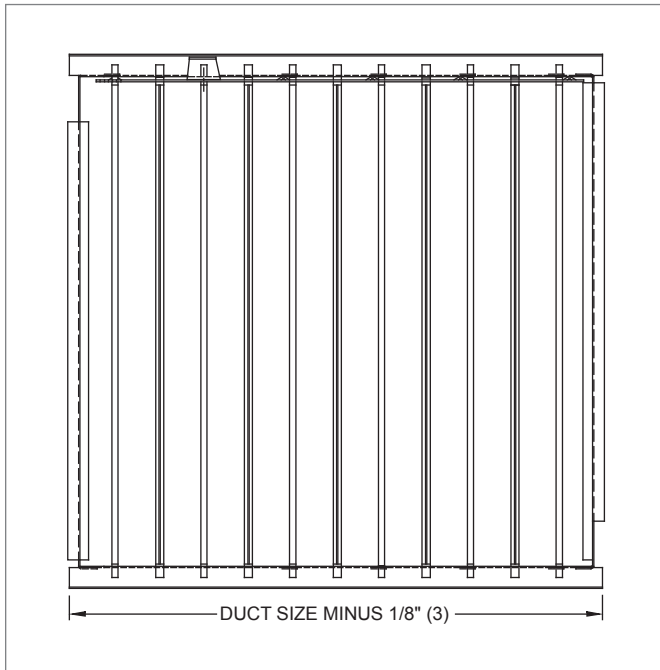
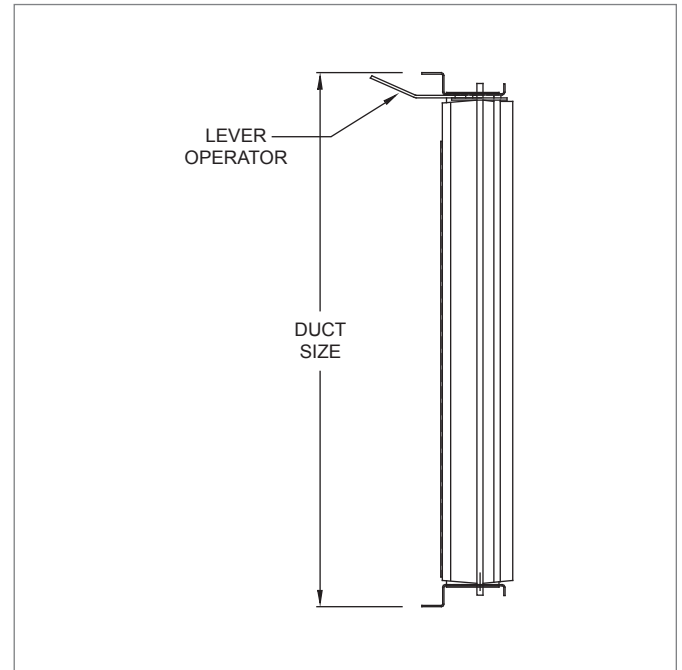
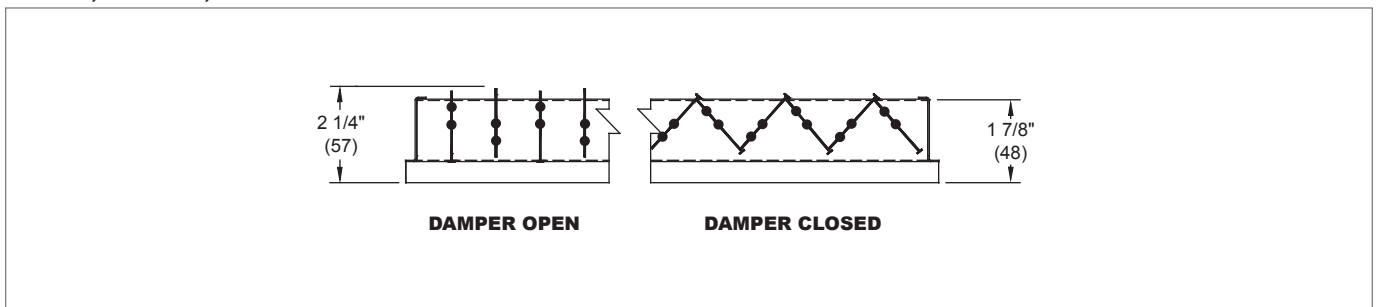

OBDFA

OBDFA/5OBDFA Dimensional Information
OBDFA, 5OBDFA, FACE VIEW

OBDFA, 5OBDFA, SIDE VIEW

OBDFA, 5OBDFA, CROSS SECTION

NOTES: Dimensions in parentheses are mm. Reference page Q1-26 for applicable product.