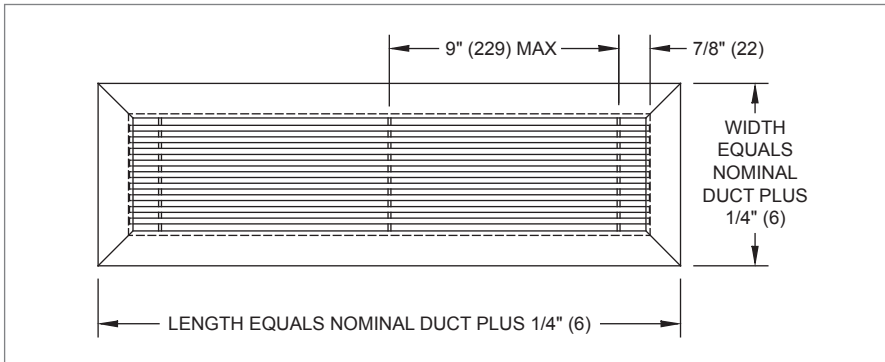
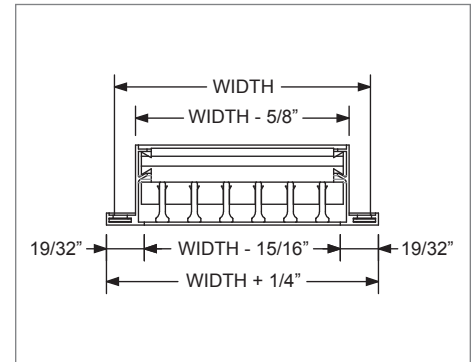
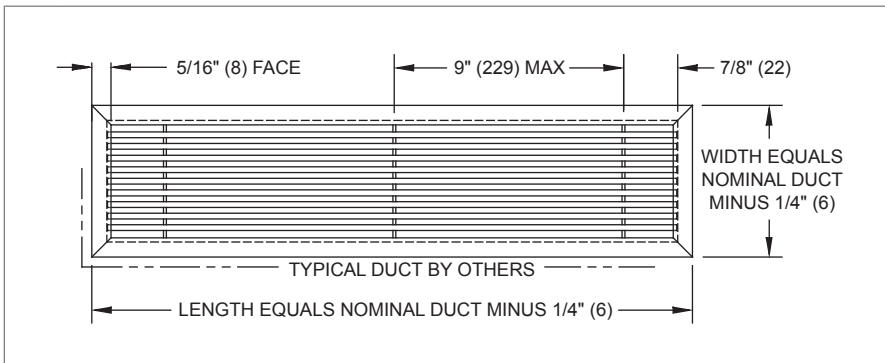
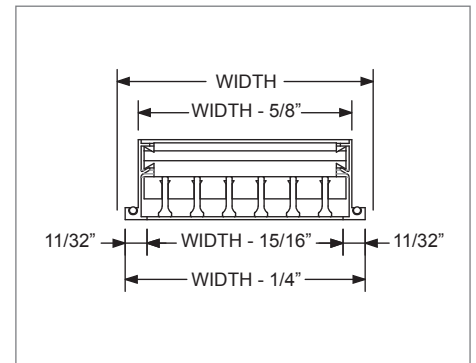
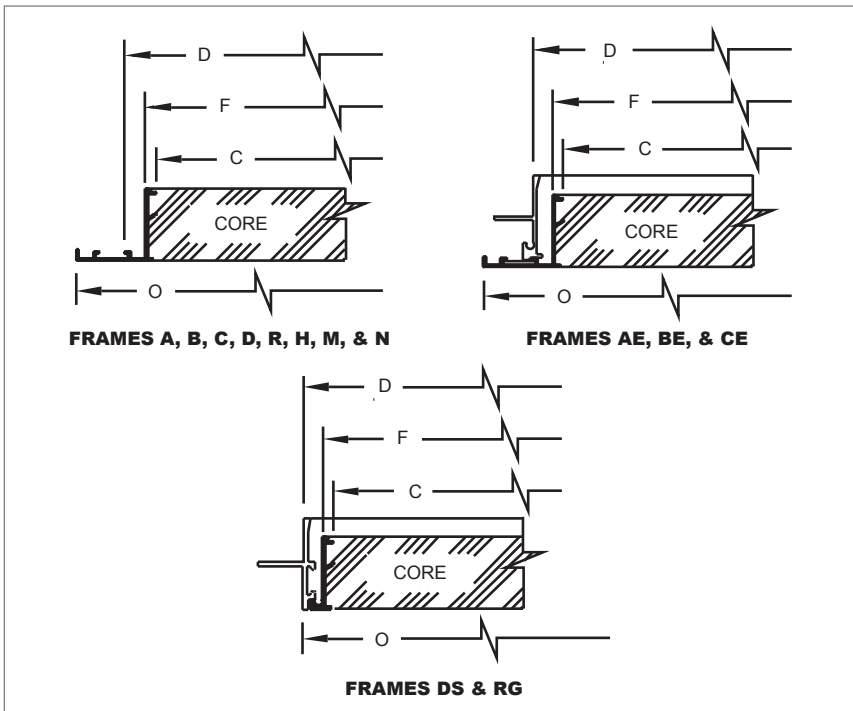

1600 Dimensional Information & Frame Styles
1600, FACE VIEW FOR FRAME STYLE D

1600, FRAME STYLE D

1600, FACE VIEW FOR FRAME STYLE R

1600, FRAME STYLE R

NOTE: Dimensions in parentheses are mm.

1600, 1850 Dimensional Information
1600, 1850, LENGTH & WIDTH DIMENSIONAL DETAIL

Frame	Frame Length	Overall Dimension	Core Opening Length
	F	O	C
A	D - 5/8"	D + 1 3/4"	D - 3/4"
B	D - 5/8"	D + 1 1/4"	D - 3/4"
C	D - 5/8"	D + 3/4"	D - 3/4"
D	D - 5/8"	D + 1/4"	D - 3/4"
R	D - 5/8"	D - 1/4"	D - 3/4"
AE	D	D + 1 3/4"	D - 3/8"
BE	D	D + 1 1/4"	D - 3/8"
CE	D	D + 3/4"	D - 3/8"
DS	D	D + 7/16"	D - 3/4"
RG	D	D	D - 3/4"
H	D	D + 2 1/4"	D - 3/8"
M	D	D + 1 5/8"	D - 3/8"
N	D	D	D - 3/8"

NOTES:

Lengths based on end caps mounted on each end.
 D = Nominal duct dimension length/width
 (or ordered length)

F = Actual overall neck dimension length/width

O = Overall face dimension length/width

C = Actual core opening length/width

1850 Dimensional Information & Frame Styles

1850, FACE VIEW FOR FRAME STYLES H, M, & N

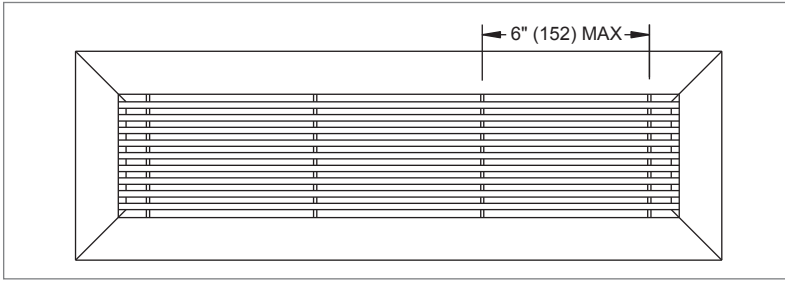

NOTES: Dimensions in parentheses are mm. For 1850 grille length and width dimensional information, see table on page K1-25.

1850, FRAME STYLES H, M, & N

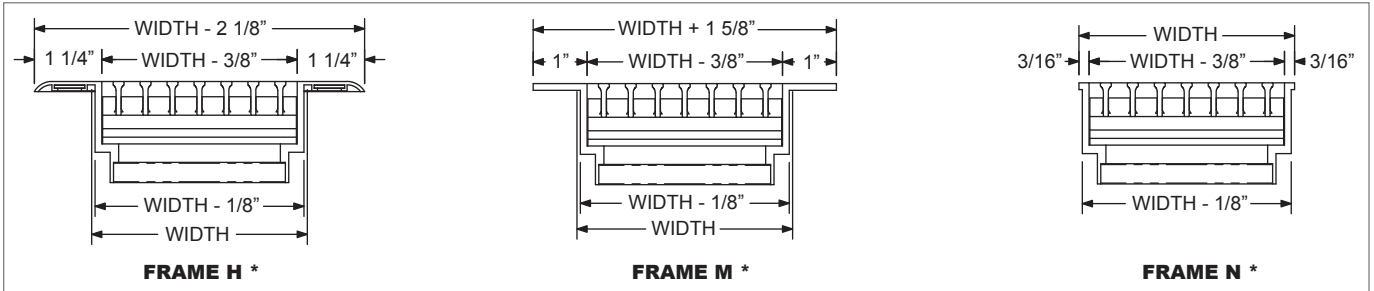

NOTES: Dimensions in parentheses are mm. Nominal duct equals ordered size. For actual dimensions, see table on page K1-25.

* Suggested floor opening for Frame H, M, and N is nominal duct size plus 1/16" (1.5).

1850 Mounting Options

1850, MOUNTING OPTIONS FOR FRAME STYLES H, M, & N

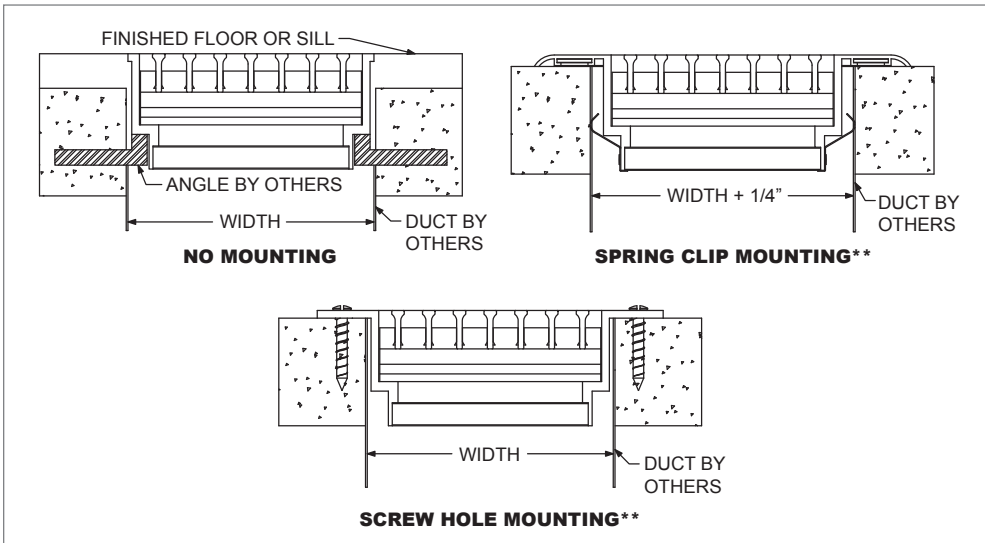

NOTES: Dimensions in parentheses are mm. ** Not available for Frame N.

1850 Deflection Patterns

1850, NORMAL AIR DEFLECTION PATTERNS (N)

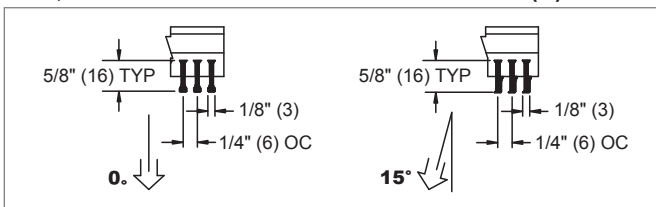

1850, EVERY OTHER DEFLECTION PATTERNS (E)

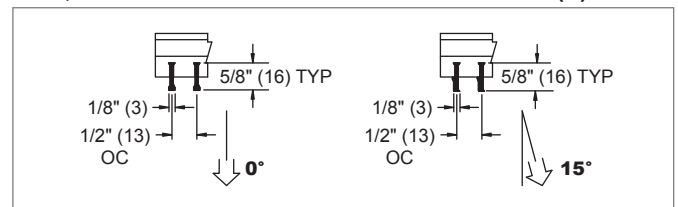

NOTE: Dimensions in parentheses are mm.

© KRUEGER 2012

1
6
0
0
-
1
8
5
0

Mitered Corner (1600MC, 1850MC) Deflection Patterns

1600MC, 1850MC, 90° DEFLECTION PATTERN

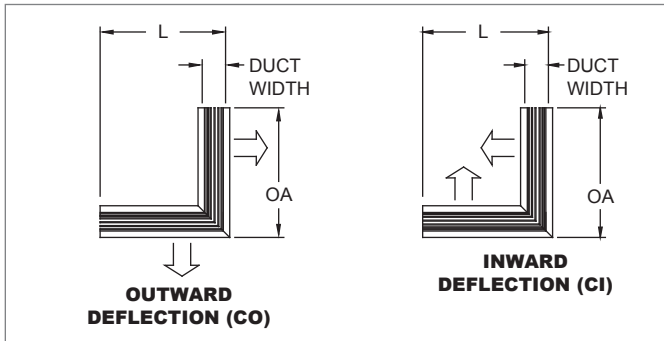

1600MC, 1850MC, 135° DEFLECTION PATTERN

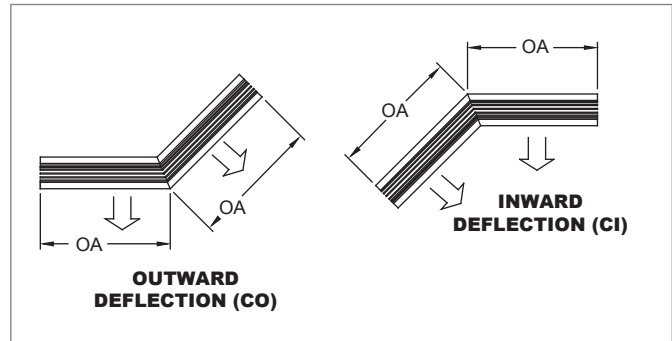

1600MC, 90° DEFLECTION PATTERN

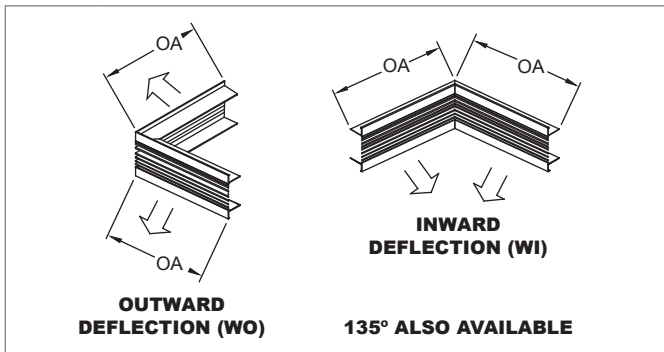

Mitered Corner (1600MC, 1850MC) Dimensional Data

1600MC, OVERALL DIMENSIONS FOR FRAME STYLES

Duct Width	Duct L	Frames									
		A	B	C	D	R	AE	BE	CE	DS	RG
2" - 4" (51 - 102)	12" (305)	12 7/8" (327)	12 5/8" (321)	12 3/8" (314)	12 1/8" (308)	11 7/8" (302)	13 3/16" (335)	12 15/16" (329)	12 5/8" (321)	12 3/16" (310)	12" (305)
4 1/2" - 12" (114 - 305)	18" (457)	18 7/8" (479)	18 5/8" (473)	18 3/8" (467)	18 1/8" (460)	17 7/8" (454)	19 3/16" (487)	18 15/16" (481)	18 5/8" (473)	18 3/16" (462)	18" (457)

1850MC, OVERALL DIMENSIONS FOR FRAME STYLES

Duct Width	Duct L	Frames		
		H	M	N
2" - 4" (51 - 102)	12" (305)	12 7/8" (327)	12 13/16" (325)	12" (305)
3" - 4" (76 - 102)	12" (305)	-	-	-
4 1/2" - 12" (114 - 305)	18" (457)	18 7/8" (479)	18 13/16" (478)	18" (457)

1850MC, MAXIMUM FLOOR LOADING

Model	Blade	Spacing	Maximum Vertical Distributed Load	Maximum Vertical Live Load	Maximum Horizontal Load
			lbs/in ²	lbs/ft ²	lbs
1850 Normal	1/8" (3)	1/4" (6)	300	300	50
1850 Every Other	1/8" (3)	1/2" (13)	200	200	50

NOTES: Dimensions in parentheses are mm. Dash indicates not available.

1600, 1850 Access Doors & Oversized Units

1600, ACCESS DOOR OPTION

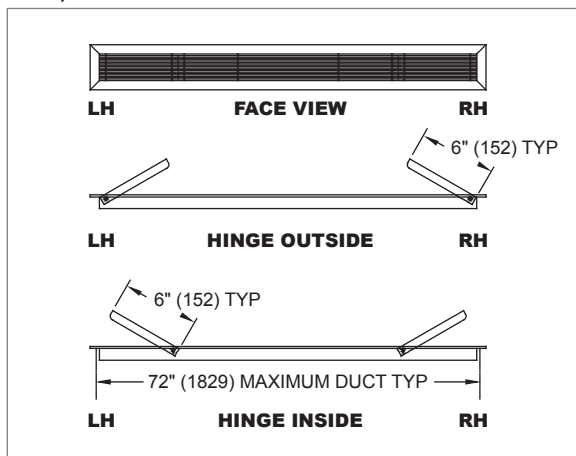

NOTES: Dimensions in parentheses are mm. Linear bar access doors provide open area approximately 5" (127) long by a width determined by the specified unit width. Access doors are not available with the 1850 models.

1600, 1850, OVERSIZED UNIT DIMENSIONAL DETAIL

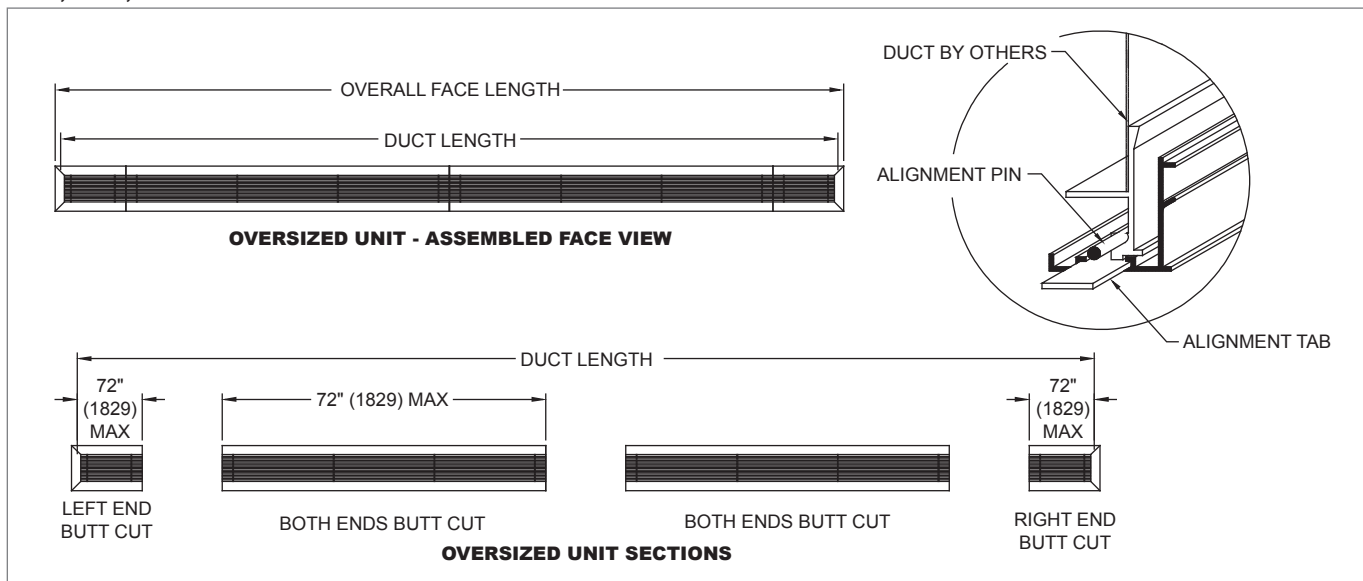

NOTES: Dimensions in parentheses are mm. Oversized units are assembled with the minimum number of sections based on a maximum individual duct length of 72". Alignment tabs and pins are provided to facilitate assembly. Alignment tabs and pins are not available with Frames M and N.

1600, 1800 Accessories

LINEAR OPPOSED BLADE DAMPER (LOBD)

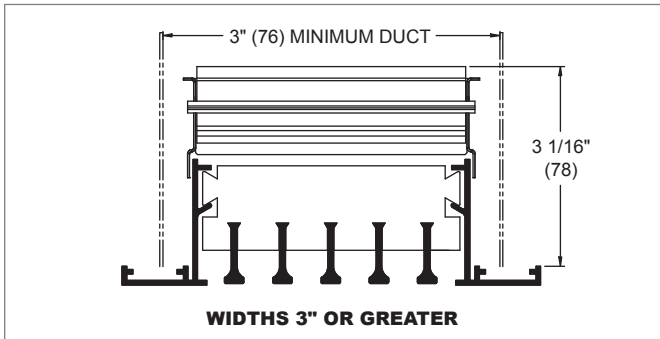

NOTES: Dimensions in parentheses are mm.
Do not use with Frames DS and RG.
Do not use with concealed mounting.

LINEAR STRAIGHTENING GRID (LSG)

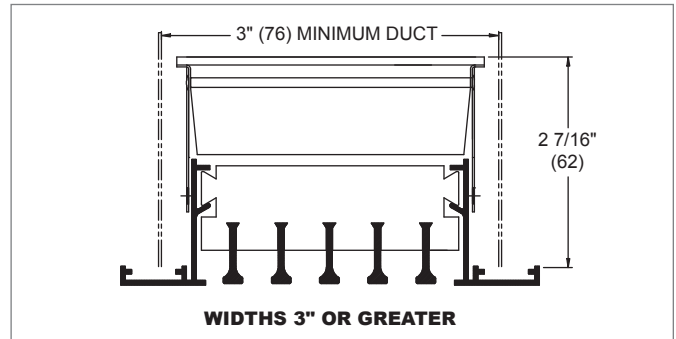

NOTES: Dimensions in parentheses are mm.
Do not use with Frames M, N, or R.
Do not use with spring clip mounting.

SINGLE BLADE DAMPER (SBD)

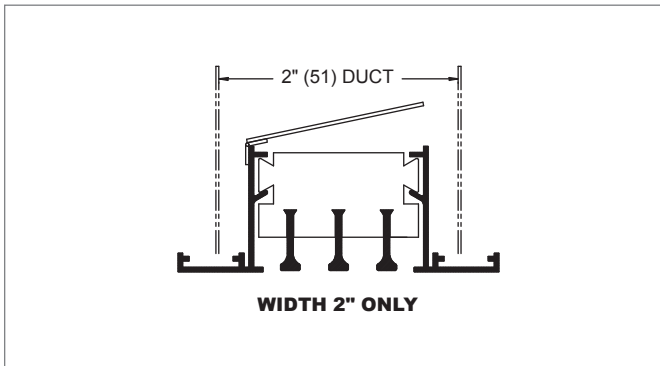

NOTES: Dimensions in parentheses are mm.
Do not use with Frames H, M, N, DS, or RG.
Do not use with concealed mounting.
Do not use with widths greater than 2" (51).

SINGLE BLADE DAMPER (SBD)

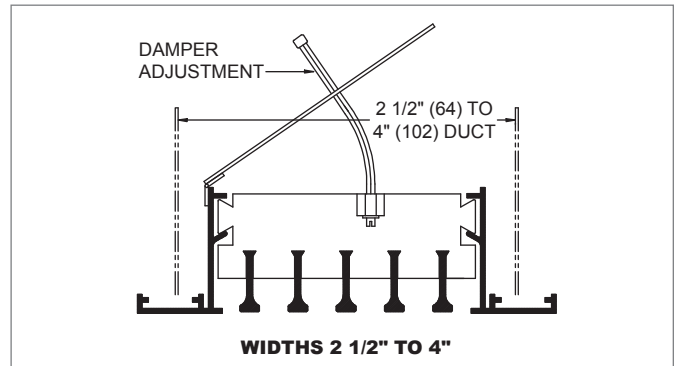

NOTES: Dimensions in parentheses are mm.
Do not use with Frames H, M, N, DS, or RG.
Do not use with concealed mounting.

BLANK-OFF STRIP (BOS)

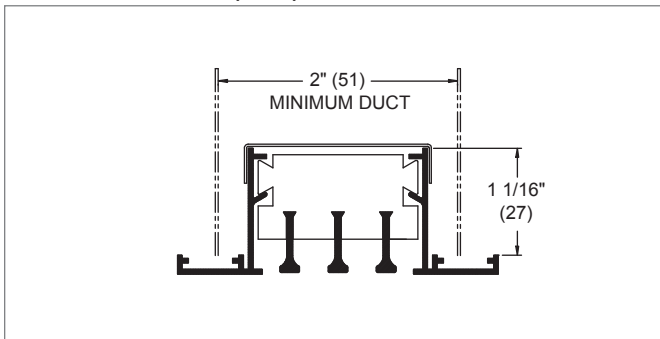

NOTES: Dimensions in parentheses are mm.
Do not use with spring clip mounting.

CORE CLIP

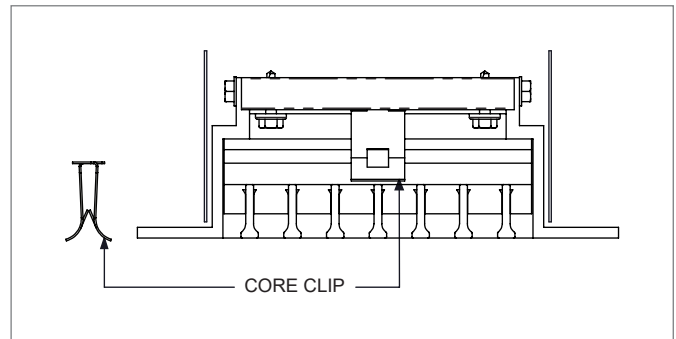

NOTES: Dimensions in parentheses are mm.
Only Available for 1800 and 1850.