

JOB NAME _____
 ARCHITECT _____
 ENGINEER _____
 CONTRACTOR _____
 LOCATION _____

SUBMITTAL SHEET
 Form Number DS3010 Effective Date 2/00
 Replaces Forms 3010 & 3634

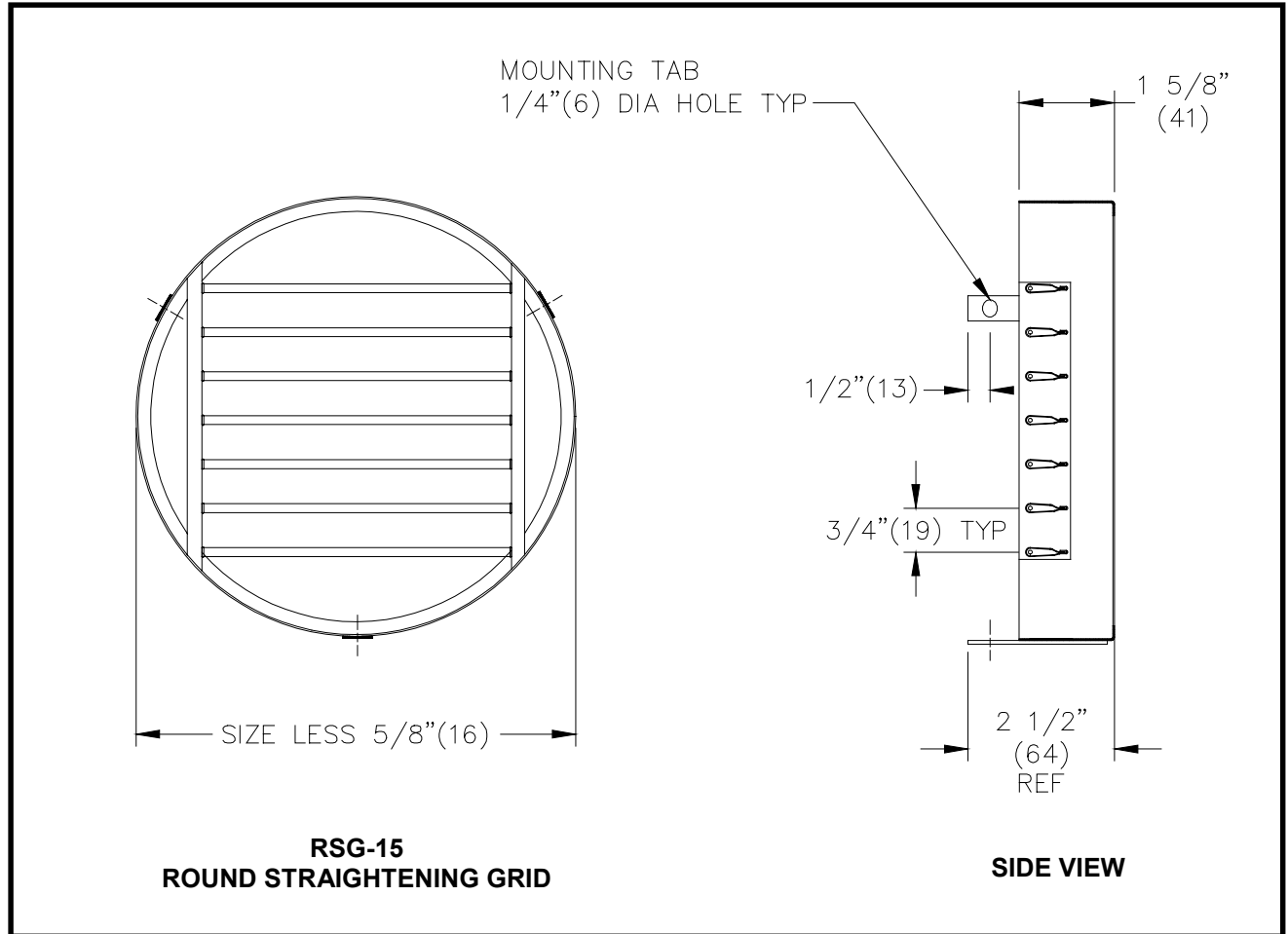

RSG-15
ROUND STRAIGHTENING GRID



NOTES :

1. STANDARD CONSTRUCTION IS 20 GA. GALVANIZED STEEL.
2. ROLL FORMED BLADES ARE INDIVIDUALLY ADJUSTABLE
3. THE **RSG-15** SHIPS SEPARATELY AND CAN BE USED IN VARIOUS APPLICATIONS.
4. MILL FINISH STANDARD.

	NOMINAL DUCT DIAMETER
RSG-15	6
	7
	8
	10
	12
	14
	15

DIMENSIONS ARE GIVEN AS INCHES (MM)