

SUBMITTAL SHEET

Form Number DS1040.1 Effective Date 5/13

Replaces Form DS1040

JOB NAME _____
ARCHITECT _____
ENGINEER _____
CONTRACTOR _____
LOCATION _____



BOS BLANK-OFF STRIP
AVAILABLE FOR USE WITH LINEAR PRODUCT LINES

BOS (STEEL)
CROSS SECTION VIEW

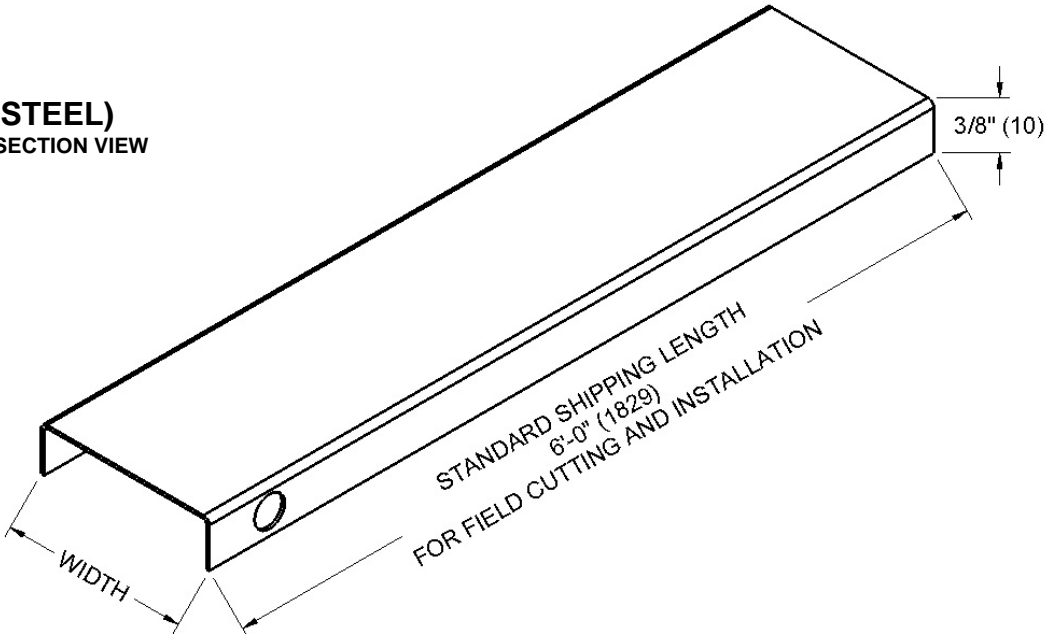

BLANK-OFF INSTALLS ON TOP OF STACKHEAD

INSTALLATION DETAIL
1900 FRAME STYLE 'C' SHOWN

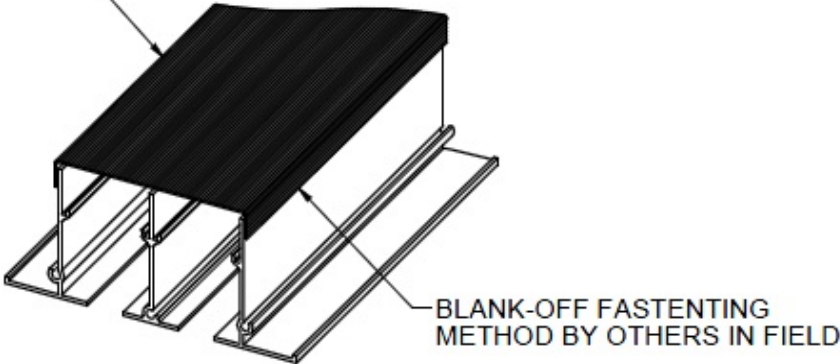

NOTES :

- 1. CONSTRUCTION IS 24 GA STEEL.
- 2. AVAILABLE FOR 1900 LINEAR SERIES.
- 3. BLANK OFF STRIPS ALWAYS SHIP SEPARATELY IN 6'-0" LENGTHS FOR FIELD CUTTING AND INSTALLATION.
- 4. BLACK FINISH IS STANDARD.

DIMENSIONS ARE GIVEN AS INCHES (MM)

Product Information is Subject to Change Without Notice