

JOB NAME _____
 ARCHITECT _____
 ENGINEER _____
 CONTRACTOR _____
 LOCATION _____

SUBMITTAL SHEET
 Form Number GSS003.2 Effective Date 5/13
 REPLACES FORM: GSS003.1

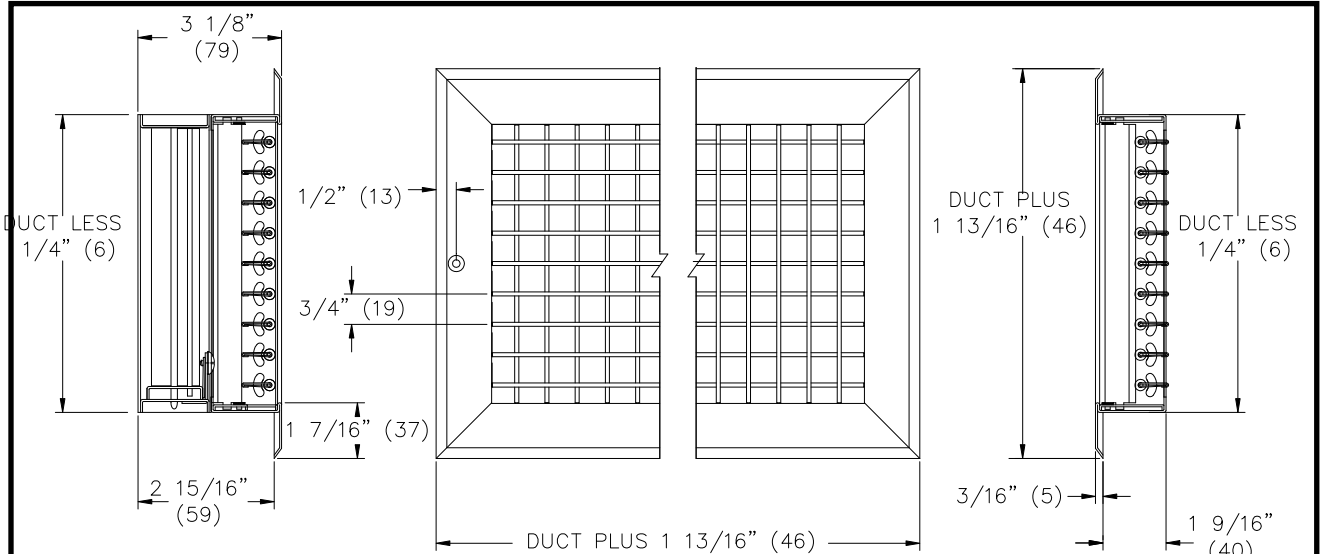

9880
STAINLESS STEEL ADJUSTABLE DOUBLE DEFLECTION SUPPLY GRILLE



9880H
FRAME 22 SHOWN w/ 9OBD

9880V
FRAME 22

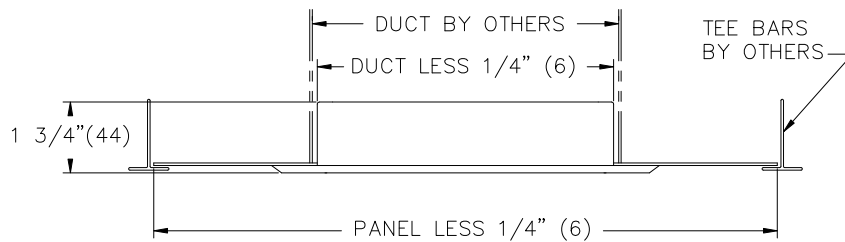

SIDE VIEW - FRAME 23
 MAX INLET EQUALS PANEL LESS 4" (102)

NOTES :

- STANDARD CONSTRUCTION IS 18 GA. 304 STAINLESS STEEL.
- 20 GA. AIRFOIL BLADES ARE INDIVIDUALLY ADJUSTABLE
- 9880H** FRONT BLADES ARE HORIZONTAL.
9880V FRONT BLADES ARE VERTICAL.
- AVAILABLE FRAME STYLES :
 FRAME 22 – SURFACE
 FRAME 23 – LAY IN TEE BAR
- STANDARD FINISH IS #3 SATIN POLISHED.

OPTIONS :

- TYPE 316 STAINLESS STEEL
- MILL FINISH
- NO SCREWHOLES
- COUNTERSUNK SCREWHOLES WITH #8 x 1-1/4" STAINLESS STEEL SHEET METAL SCREWS
- 9OBD** - 20 GA STAINLESS STEEL OPPOSED BLADE DAMPER IS WELDED TO THE UNIT AND OPERATED BY A SCREWDRIVER.
- 9SRA** - SQUARE TO ROUND ADAPTER

**DIMENSIONS ARE GIVEN AS
 INCHES (MM)**

Product Information is Subject to Change Without Notice