

JOB NAME _____
 ARCHITECT _____
 ENGINEER _____
 CONTRACTOR _____
 LOCATION _____

SUBMITTAL SHEET
 Form Number GS0019.3 Effective Date 5/13
 replaces FORM GS0019.2

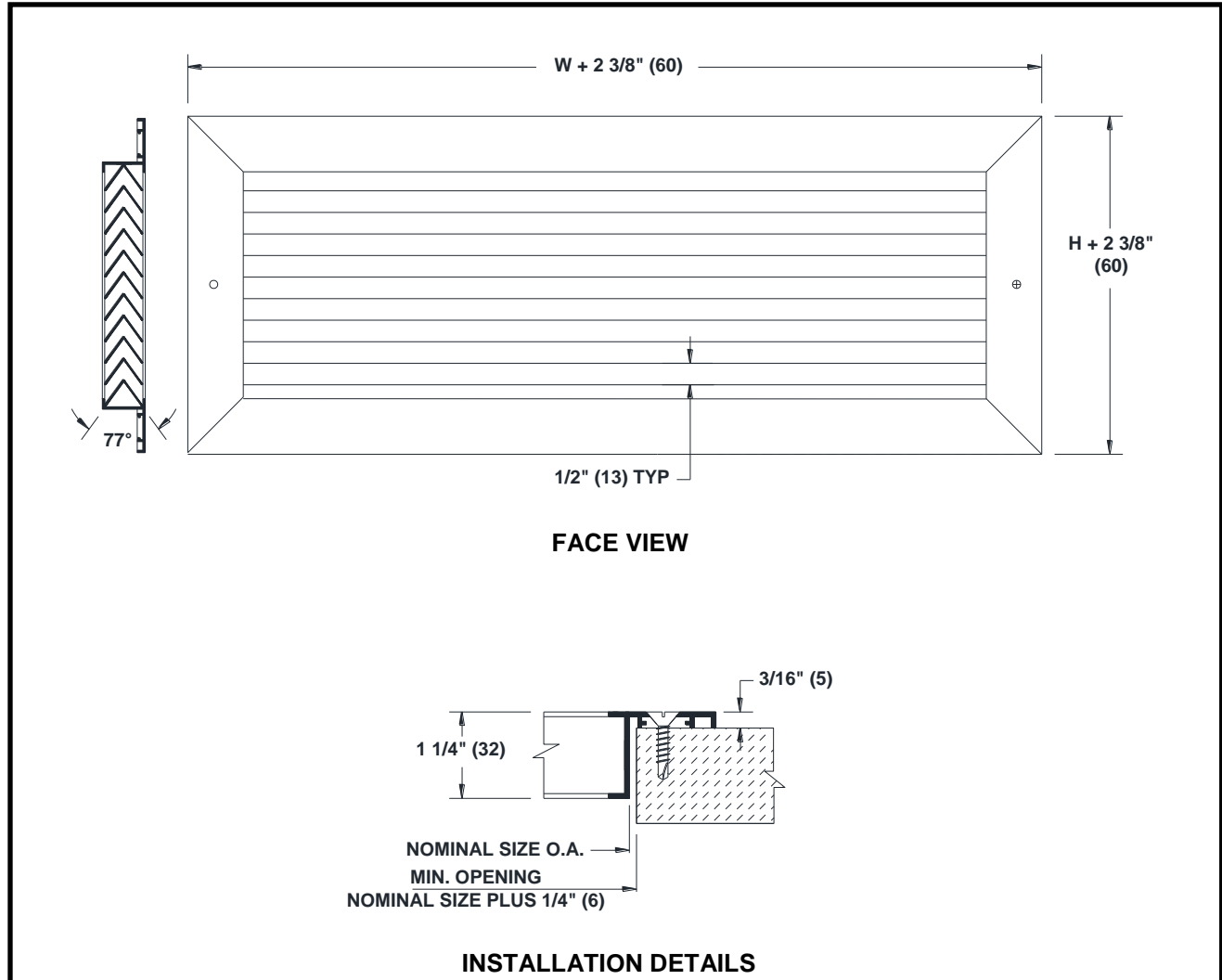

5600 SERIES NON VISION GRILLE
SIDEWALL / DOOR APPLICATION



FACE VIEW

INSTALLATION DETAILS

**DIMENSIONS GIVEN AS
 INCHES (MM)**

NOTES :

1. NON-VISION GRILLES ARE DESIGNED FOR USE IN DOORS, WALLS, PARTITIONS OR OTHER APPLICATIONS WHERE PRIVACY WITH CONSTANT AIR PASSAGE IS REQUIRED.
2. CONSTRUCTION IS ALUMINUM.
3. STANDARD FINISH IS #44 BRITISH WHITE. ADDITIONAL COLORS ARE AVAILABLE.
4. THE MAXIMUM SIZE OF A SINGLE CORE UNIT IS 30"x30" UNITS UP TO 36"x36" WILL HAVE TWO CORES BUTTED SIDE BY SIDE IN A SINGLE FRAME.