

# 5DMGPU SERIES

Perforated Universal Duct Mounted Grille - Aluminum Construction

# SUBMITTAL SHEET

5DMGPU TOP SECTION VIEW

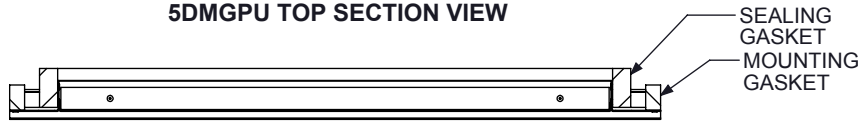

SIDE SECTION VIEW

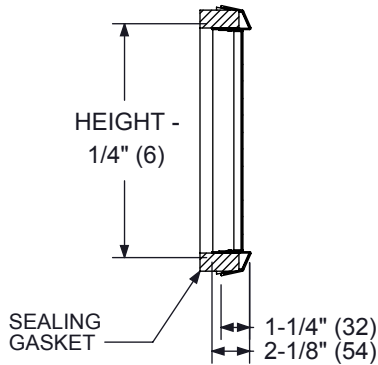

5DMGPU FACE VIEW

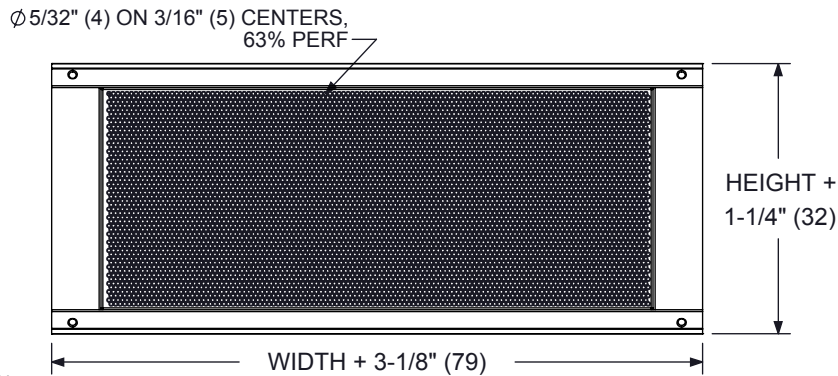

SIDE VIEW

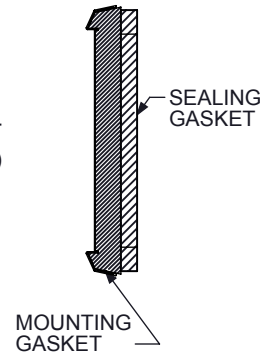

5DMGPU BOTTOM SECTION VIEW

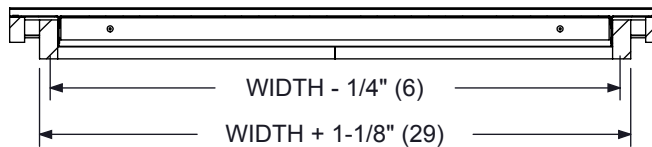

**NOTES:**

1. ALL ALUMINUM CONSTRUCTION
2. STANDARD FINISH 44 WHITE OR 81 CLEAR ANODIZED.
3. DIMENSIONS ARE INCHES (MM)
4. DUCT DIAMETER AVAILABLE IN EVEN SIZES ONLY.
5. PERFORATED FACE FREE AREA IS 63% -5/32" DIAMETER HOLES ON 3/16" SPACING
6. GASKET MATERIAL IS POLYURETHANE FOAM AND WILL COMPRESS WHEN INSTALLED
7. HOLE OPENING IS EQUAL TO ORDERED WIDTH x HEIGHT

 5DMGPU

Height	3	4	6	8	10
Duct Diameter (Min / Max)	6 / 36	10 / 36	12 / 36	20 / 36	24 / 36
Width (Min / Max)	10 / 48		14 / 48		16 / 48

# 5DMGPU SERIES

Perforated Universal Duct Mounted Grille - Aluminum Construction

# SUBMITTAL SHEET

With Damper/Extractor

5DMGPU TOP SECTION VIEW

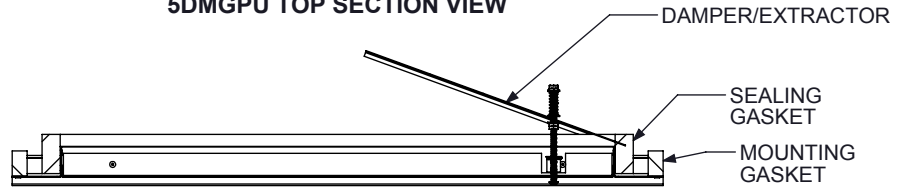

SIDE SECTION VIEW

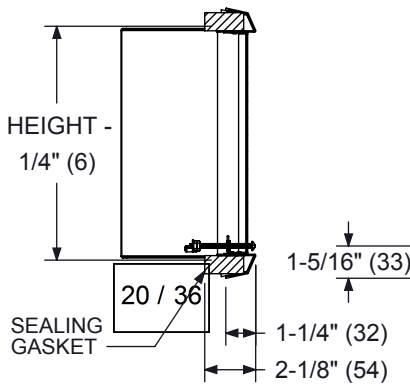

5DMGPU FACE VIEW

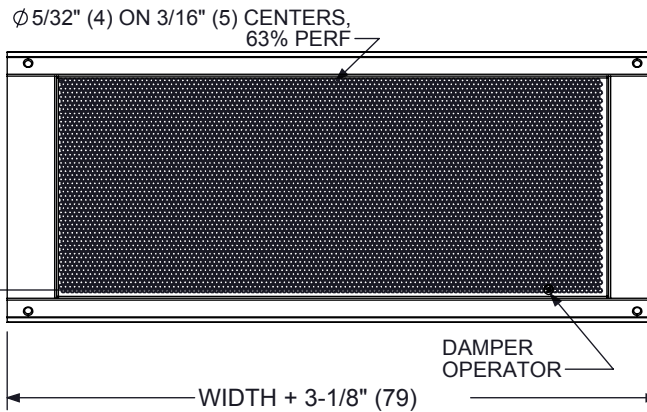

SIDE VIEW

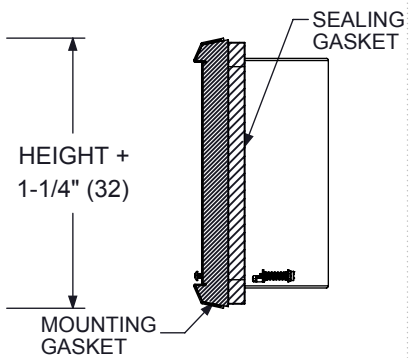

5DMGPU BOTTOM SECTION VIEW

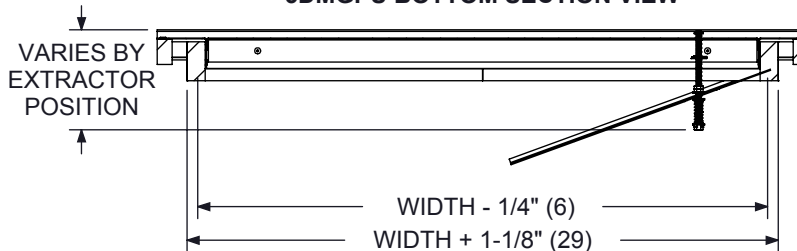

□ 5DMGPU

**NOTES:**

- ALL ALUMINUM CONSTRUCTION
- STANDARD FINISH 44 WHITE OR 81 CLEAR ANODIZED.
- DIMENSIONS ARE INCHES (MM)
- DUCT DIAMETER AVAILABLE IN EVEN SIZES ONLY.
- PERFORATED FACE FREE AREA IS 63% -5/32" DIAMETER HOLES ON 3/16" SPACING
- GASKET MATERIAL IS POLYURETHANE FOAM AND WILL COMPRESS WHEN INSTALLED
- HOLE OPENING IS EQUAL TO ORDERED WIDTH x HEIGHT

Height	3	4	6	8	10
Duct Diameter (Min / Max)	6 / 36	10 / 36	12 / 36	20 / 36	24 / 36
Width (Min / Max)	10 / 48		14 / 48		16 / 48