

JOB NAME _____
 ARCHITECT _____
 ENGINEER _____
 CONTRACTOR _____
 LOCATION _____

SUBMITTAL SHEET
 Form Number GS0030.4 Effective Date 5/13
 Replaces Form DS0030.3

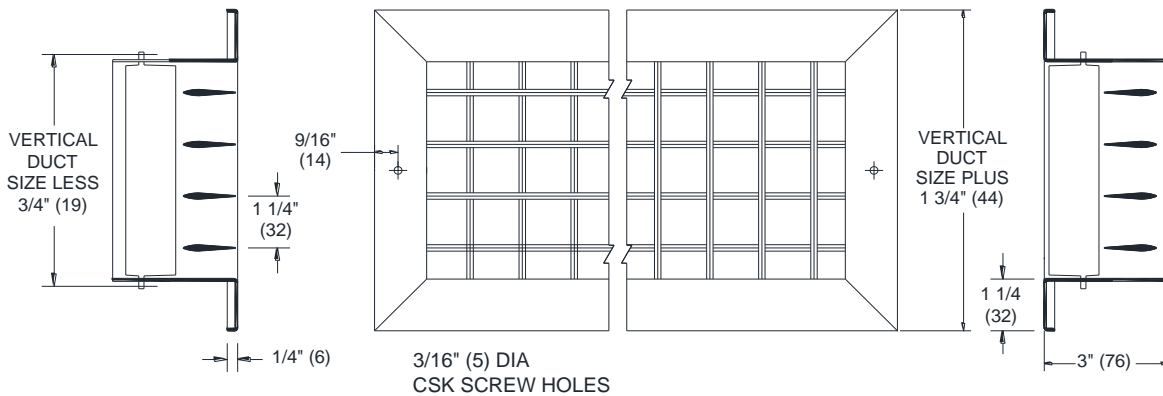

6880-15, 56880-15 SERIES
INDUSTRIAL DOUBLE DEFLECTION SUPPLY GRILLE



6880H-15

6880V-15

56880H-15

56880V-15

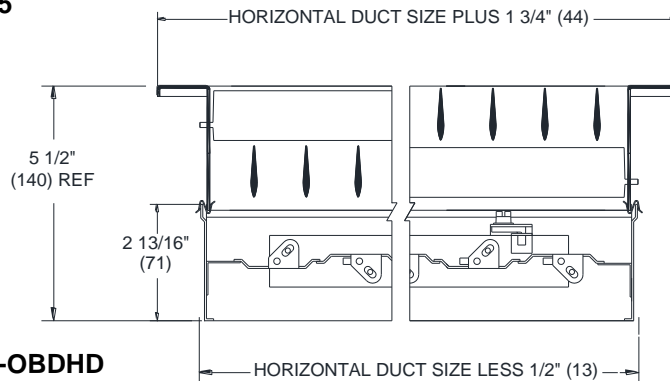

6880H-15-OBDD

6880V-15-OBDD

56880H-15-OBDD

56880V-15-OBDD

NOTES:

1. 6880-15 SERIES IS STEEL CONSTRUCTION WITH ADJUSTABLE EXTRUDED ALUMINUM BLADES
2. 56880-15 SERIES IS ALUMINUM CONSTRUCTION WITH ADJUSTABLE EXTRUDED ALUMINUM BLADES
3. MINIMUM SIZE OFFERED IS 6"x6" (152X152)
4. MAXIMUM SINGLE UNIT SIZE IS 48"x48" (1219x1219). MULTIPLE SECTIONS ARE FURNISHED FOR LARGER SIZES
5. STANDARD FINISH IS 44 BRITISH WHITE

ACCESSORIES:

- OBDD** STEEL HEAVY DUTY OPPOSED BLADE DAMPER

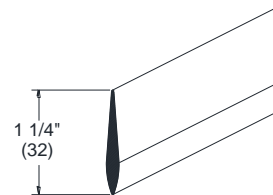

(5)6880-15 BLADE DETAIL

DIMENSIONS ARE GIVEN AS INCHES (MM)