

JOB NAME _____
 ARCHITECT _____
 ENGINEER _____
 CONTRACTOR _____
 LOCATION _____

SUBMITTAL SHEET
 Form Number GS209.4 Effective Date 05/13
 Replaces Form GS0209.3



S580H, V or HZ, VZ SERIES

3/4" Spaced Fixed Blade Aluminum Return Grille

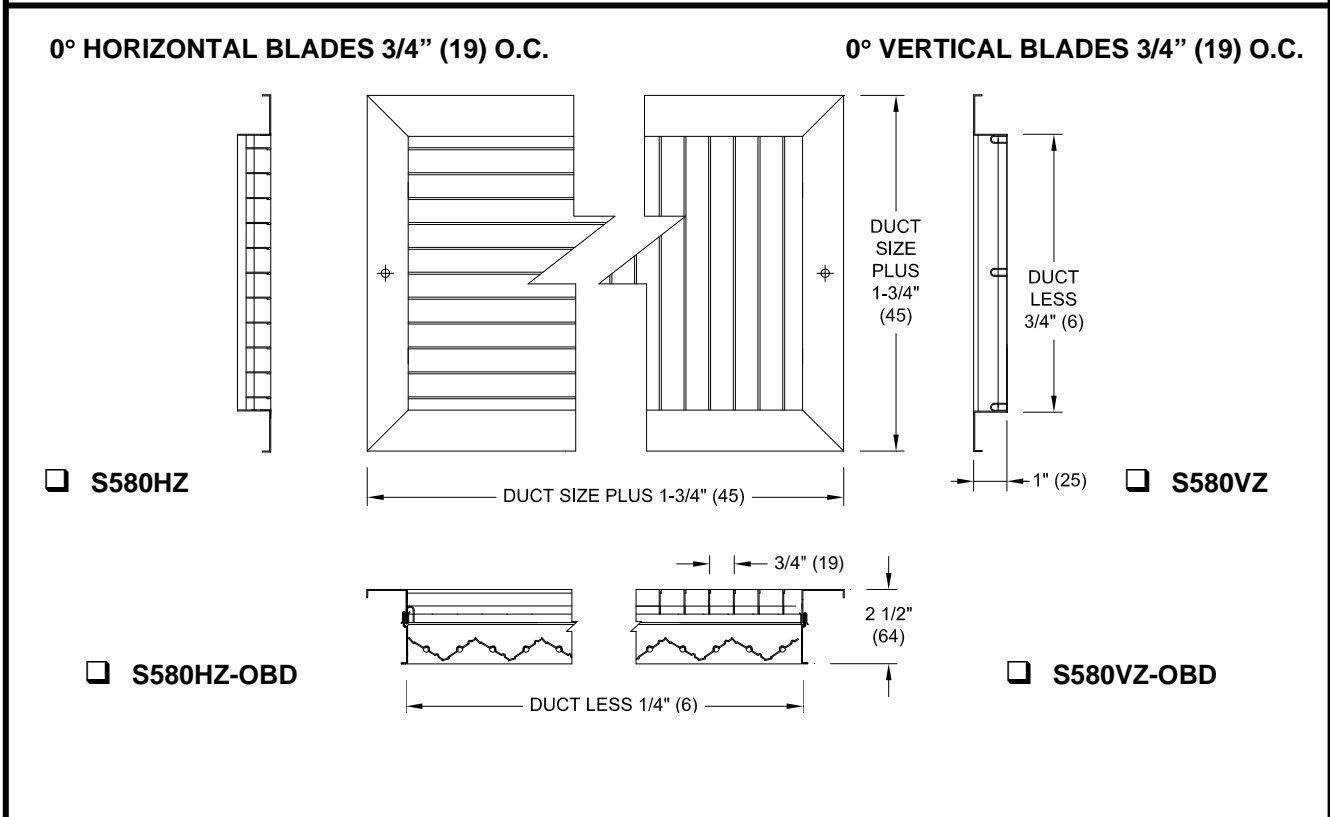
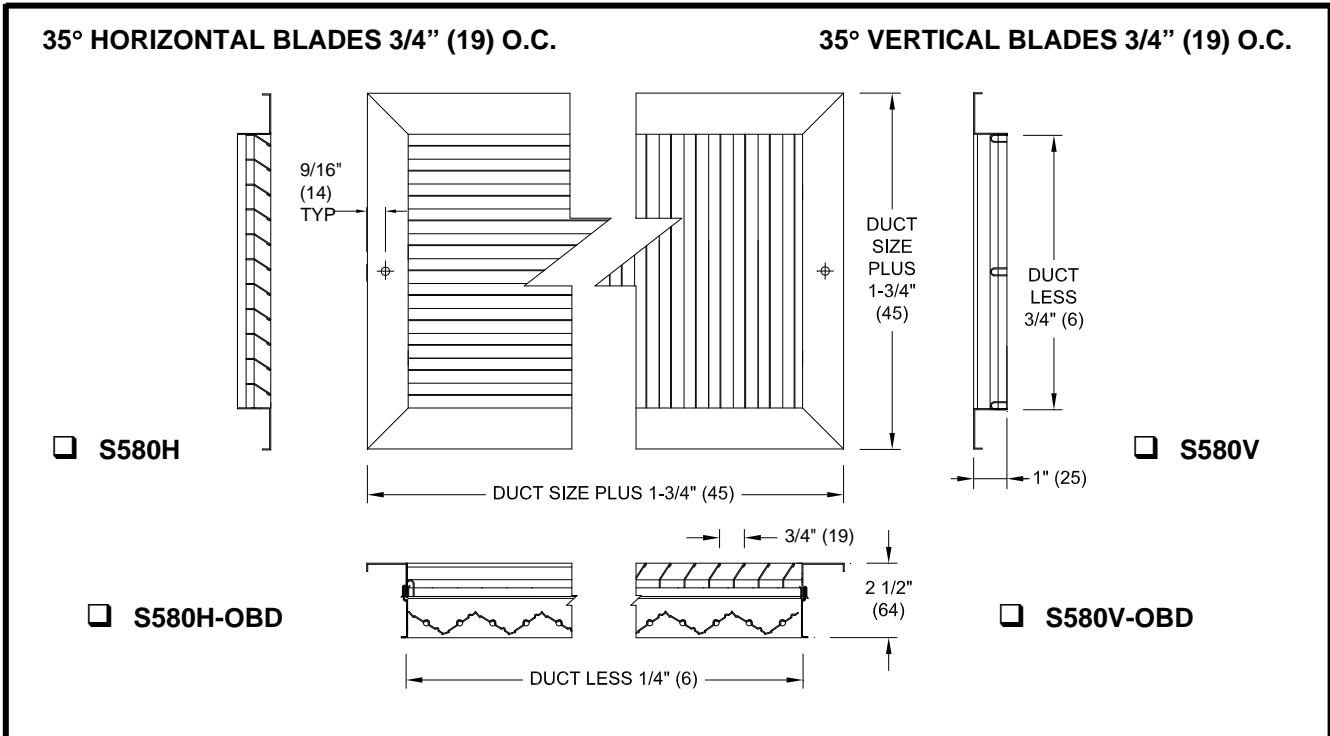

JOB NAME _____
 ARCHITECT _____
 ENGINEER _____
 CONTRACTOR _____
 LOCATION _____



S580H, V or HZ, VZ SERIES
Options and Accessories

BASIC FRAME STYLES

Frame 22
SURFACE MOUNT

Frame 23
LAY-IN T-BAR

Frame 98
NARROW TEE

BASIC FASTENING METHODS

NO SCREW HOLES

STANDARD SCREW HOLES

CONCEALED FASTENING

Shown to the right

OBD/5OBD not available with concealed mounting

FILTER FRAME OPTION

Frame 23 Shown **Frame 98 Shown**

Frame 22 Shown

KNURLED / HINGE TOP

KNURLED / HINGE BOTTOM

KNURLED / HINGE RIGHT

KNURLED / HINGE LEFT

KNURLED / NO HINGE

1/4 TURN / HINGE TOP

1/4 TURN / HINGE BOTTOM

1/4 TURN / HINGE RIGHT

1/4 TURN / HINGE LEFT

1/4 TURN / NO HINGE

DIMENSIONS ARE SHOWN AS INCHES (MM)

* MAX NOMINAL DUCT SIZE FOR F23 AND F98 IS PANEL MINUS 4"

NOTES :
 S580H / V / HZ / VZ ARE ALL ALUMINUM CONSTRUCTION. SUPPORT MULLIONS 8" (203) O.C.

DIMENSIONS ARE SHOWN AS INCHES (MM)

OPTIONAL ACCESSORIES :

OBD (22 GA) STEEL OPPOSED BLADE DAMPER

POBD (22 GA) STEEL OPPOSED BLADE DAMPER PAINTED FINISH

5OBD ALUMINUM OPPOSED BLADE DAMPER

PLASTER FRAME

1" FILTER FRAME (NOT AVAILABLE WITH OBD)

2" FILTER FRAME (NOT AVAILABLE WITH OBD)