

JOB NAME \_\_\_\_\_  
 ARCHITECT \_\_\_\_\_  
 ENGINEER \_\_\_\_\_  
 CONTRACTOR \_\_\_\_\_  
 LOCATION \_\_\_\_\_

**SUBMITTAL SHEET**  
 Form Number GS0010.4 Effective Date 09/12  
 Replaces GS0010.3

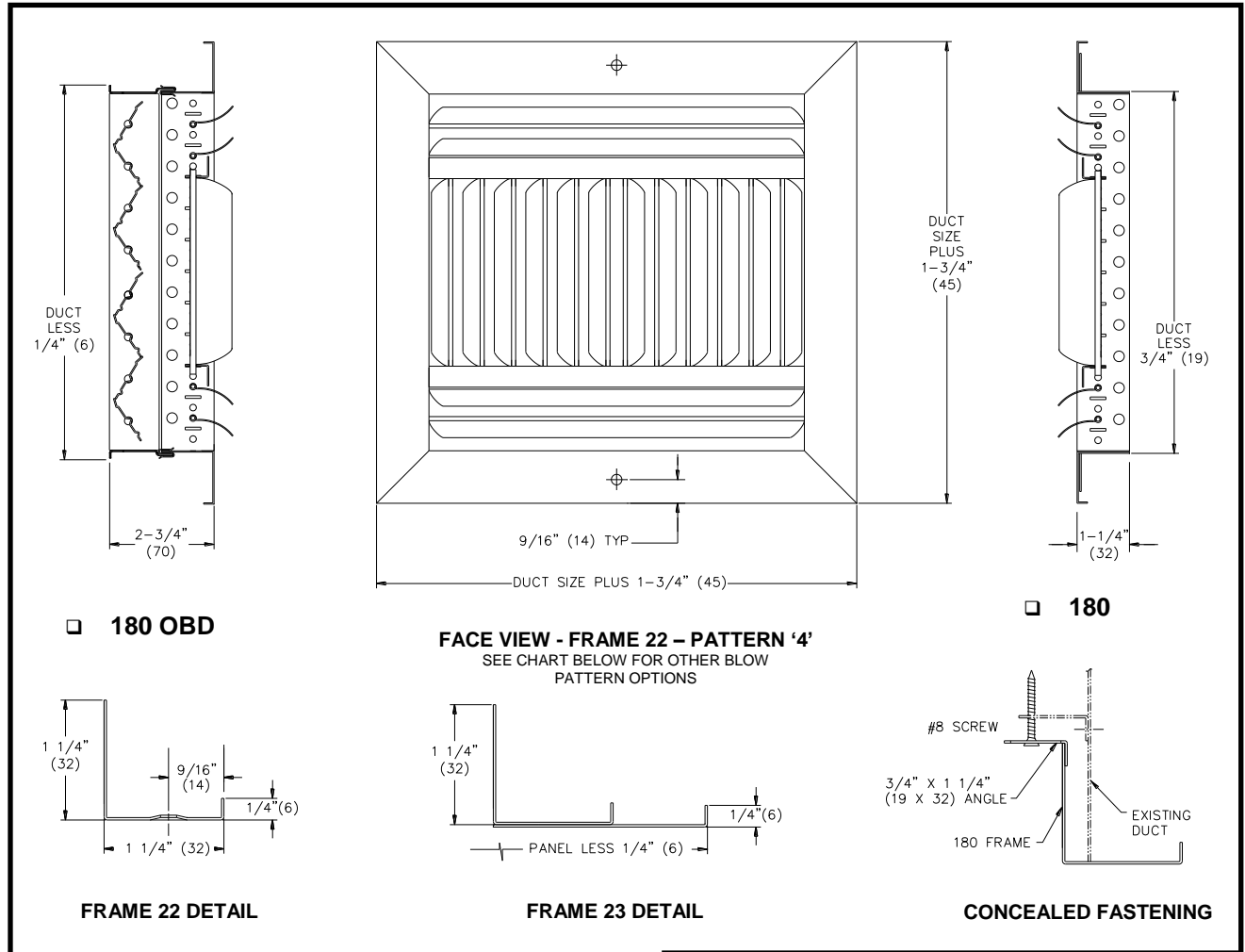

**SERIES 180**  
**CURVED BLADE, MULTI - DEFLECTION STEEL DIFFUSER**



**NOTES :**

1. 180 CONSTRUCTION IS 22 GA. STEEL
2. EACH BLADE IS INDIVIDUALLY ADJUSTABLE.
3. STANDARD FINISH IS 44 WHITE

**OPTIONS :**

- NO SCREW HOLES
- CONCEALED FASTENING

**ACCESSORIES :**

- OBD STEEL OPPOSED BLADE DAMPER
- 8PF STEEL PLASTER FRAME
- SRAC325 STEEL SQUARE TO ROUND ADAPTER

DIMENSIONS ARE SHOWN AS  
 INCHES (MM)

1-WAY	2-WAY	3-WAY	4-WAY
1	2	3	4
1S	2S	3C	4S
1L	2L	2CL	