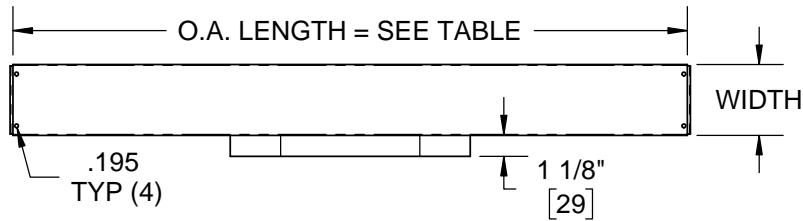
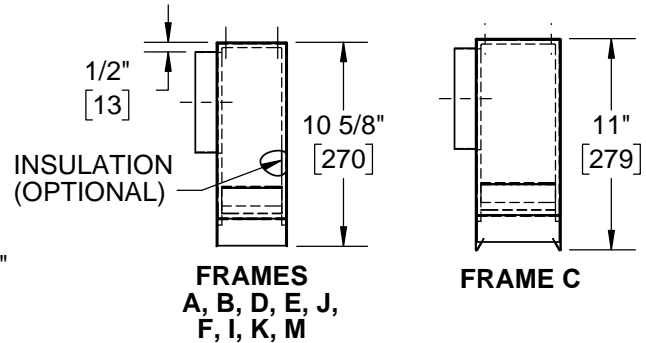
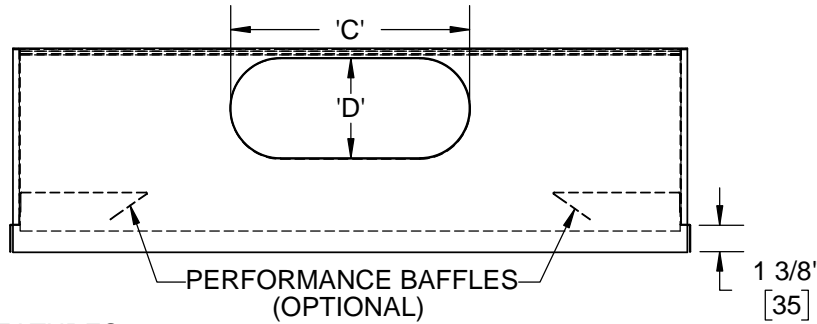

1900 BOOT
FRAMES A, B, C, D, E, F, I, J, K, M
SUBMITTAL SHEET

INLET SIZE	'C'	'D'
6" OVAL	6 1/4 (159)	5 1/4 (133)
8" OVAL	9 3/8 (238)	
10" OVAL	12 1/2 (318)	
12" OVAL	14 1/8 (359)	

FEATURES:

- 1) 24 GA. Galvanized Steel Construction
- 2) Mill Finish is Standard

OPTIONS:

- Inlet Damper (Ships Separately for Field Attachment)
- Internal 1/4", 2 lb Density Fiberglass Insulation
 - Insulated End Caps
- External Foil Encapsulated 1/2", 1.5 lb Density Fiberglass Insulation
- Internal Closed Cell 3/8" Insulation
 - Insulated End Caps
- Performance Baffles

AVAILABLE LENGTHS (L)	
24"	(610)
36"	(914)
48"	(1219)
60"	(1524)
72"	(1829)

NOTES:

- End Caps are Not Insulated (Standard)
- See Form DS0710 For End Treatment and Length Details

DIMENSIONS ARE GIVEN AS INCHES (MM)

	FRAME STYLES	
	A / B / C / F I / J / K / M	D / E
END BORDER	O.A. LENGTH	
'E' (2) END CAPS	L - 7/8 (22)	L - 1/4 (6)
'B' (2) BUTT CUT	L - 1/4 (6)	
'P' (2) END PLATES		

MODEL	WIDTH DIMENSION FOR FRAMES A, B, J, F, I, K & M							
	NUMBER OF SLOTS							
	1	2	3	4	5	6	7	8
1950	1 7/16 (37)	2 11/16 (68)	3 15/16 (100)	5 3/16 (132)	6 7/16 (164)	7 11/16 (195)	8 15/16 (227)	10 3/16 (259)
1975	1 11/16 (43)	3 3/16 (81)	4 11/16 (119)	6 3/16 (157)	7 11/16 (195)	9 3/16 (233)	10 11/16 (271)	12 3/16 (310)
1910	1 15/16 (49)	3 11/16 (94)	5 7/16 (138)	7 3/16 (183)	8 15/16 (227)	10 11/16 (271)	12 7/16 (316)	14 3/16 (360)
1915	2 7/16 (62)	4 11/16 (119)	6 15/16 (176)	9 3/16 (233)	N/A			
1920	2 15/16 (75)	5 11/16 (144)	8 7/16 (214)	11 3/16 (284)				

MODEL	WIDTH DIMENSION FOR FRAMES C, D & E							
	NUMBER OF SLOTS							
	1	2	3	4	5	6	7	8
1950	2 3/16 (56)	3 7/16 (87)	4 11/16 (119)	5 15/16 (151)	7 3/16 (183)	8 7/16 (214)	9 11/16 (246)	10 15/16 (278)
1975	2 7/16 (62)	3 15/16 (100)	5 7/16 (138)	6 15/16 (176)	8 7/16 (214)	9 15/16 (252)	11 7/16 (291)	12 15/16 (329)
1910	2 11/16 (68)	4 7/16 (113)	6 3/16 (157)	7 15/16 (202)	9 11/16 (246)	11 7/16 (291)	13 3/16 (335)	14 15/16 (379)
1915	3 3/16 (81)	5 7/16 (138)	7 11/16 (195)	9 15/16 (252)	N/A			
1920	3 11/16 (94)	6 7/16 (164)	9 3/16 (233)	11 15/16 (303)				

Revision Date: 10/17	Form: DS0711.10	Replaces: DS0711.9
----------------------	-----------------	--------------------