

JOB NAME _____
 ARCHITECT _____
 ENGINEER _____
 CONTRACTOR _____
 LOCATION _____

SUBMITTAL SHEET
 Form Number DS6100.3 Effective Date 9/12
 Replaces Form DS6100.2



6100 / 56100 Four Way Series

24"x24" PANEL

Perforated Diffuser, Round Neck & Stamped Core

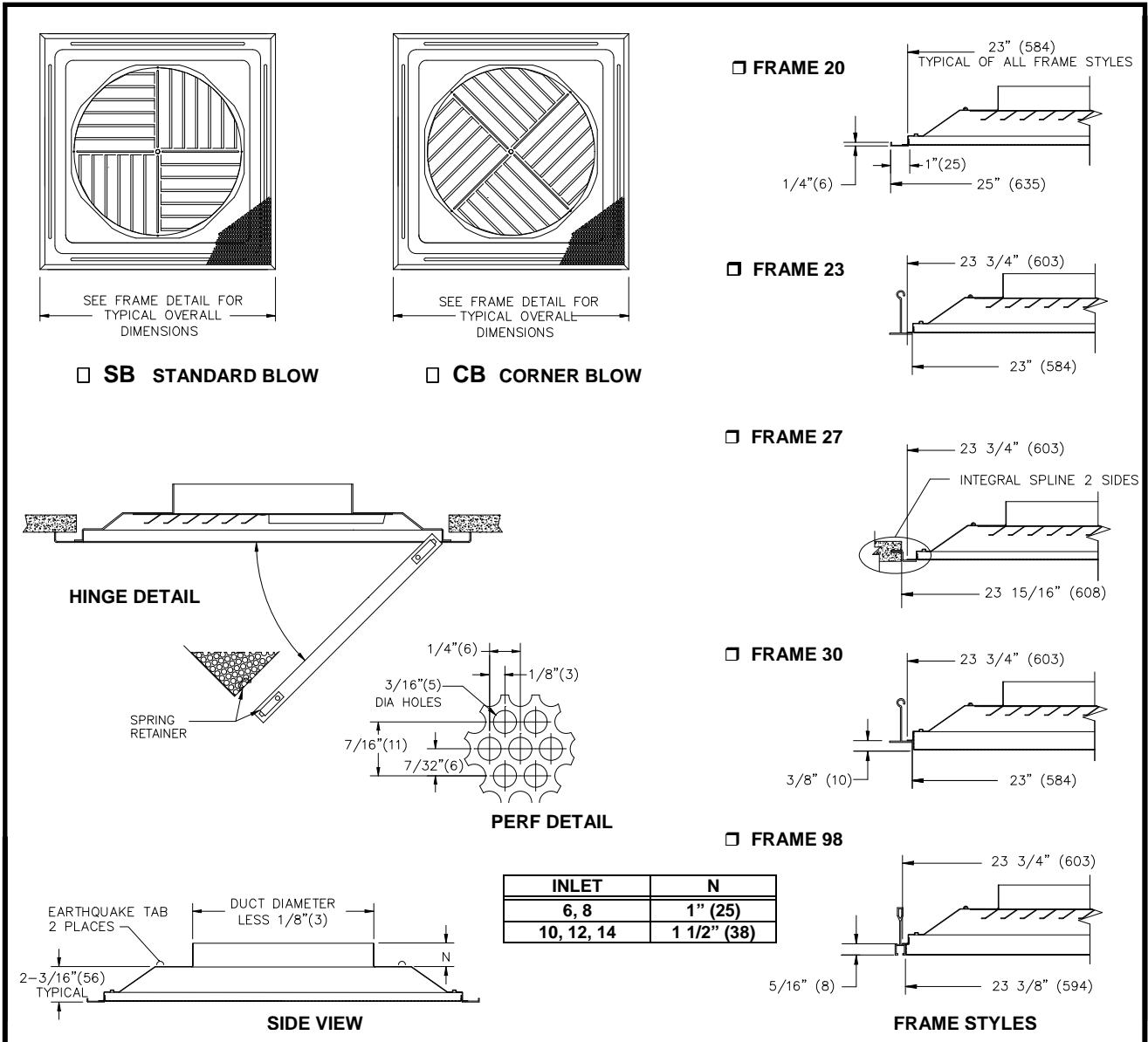

INLET	N
6, 8	1" (25)
10, 12, 14	1 1/2" (38)

	PANEL SIZES					
	12x12 (305x305)	16x16 (406x406)	20x20 (508x508)	24x24 (610x610)	24x12 (610x305)	48x24(1219x610)
INLET SIZES AVAILABLE	N/A	N/A	N/A	6 (152)	N/A	N/A
	DIMENSIONS ARE GIVEN AS INCHES (MM)			8 (203)	SEE SERIES 6590 OR 56590 FOR MATCHING RETURN	
				10 (254)		
				12 (305)		
				14 (356)		
			15 (381)			

- NOTE :**
- 6100 CONSTRUCTION IS ALL STEEL.
 - 56100 CONSTRUCTION IS STEEL WITH ALUMINUM PERF.
 - SB AND CB SELF CENTERING CORES CAN BE ROTATED IN 45° INCREMENTS IN THE FIELD.
 - STANDARD FINISH IS BRITISH WHITE.